

On the Sixth Mechanism of Lightning Injury

(An original paper submitted for the purposes of *philosophiae doctor*)

Submitted by:

Dr Ryan Blumenthal

Senior Specialist

Department of Forensic Medicine University of Pretoria South Africa

PO Box 2034 Pretoria 0001

Tel: + 27 (0) 12 323 52 98

Tel: + 27 (0) 12 319 25 41

Fax: + 27 (0) 12 323 09 21

E-mail: ryan.blumenthal@up.ac.za

On the sixth mechanism of lightning injury

Ryan Blumenthal

FEBRUARY 1ST, 2015

A thesis submitted to the Faculty of Engineering and the Built Environment, University of the Witwatersrand, Johannesburg, in fulfilment of the requirements for the Degree of Doctor of Philosophy.

Declaration

I, Ryan Blumenthal, declare that this thesis is my own unaided work. It is being submitted for purposes of the degree of Doctor of Philosophy at the University of the Witwatersand, Johannesburg. It has not been submitted before for any degree or examination at this or any other university.

Signed this 1st day of February 2015

Ryan Blumenthal

Abstract

The work presented in this thesis extends and contributes to research in the field of lightning injury mechanisms. Six mechanisms have been described in the literature about lightning injury. This thesis takes an in-depth look at the sixth injury mechanism. The sixth mechanism may be thought of as a 'pressure-shock wave' which is directly proportional to the current of the lightning discharge, and which is present immediately surrounding lightning's luminous channel. A literature review, case studies and two novel experiments helped confirm the sixth mechanism's existence. The medical data and the lightning data were then aligned. Two main questions were addressed, namely within what range is a human at risk; and what is the risk of lightning's pressure shock wave. This 'pressure-shock wave' may explain some of the more curious lightning injury patterns seen on lightning-strike victims. Knowledge and insight into the sixth mechanism may have direct and indirect applications to those working in the fields of lightning injury and lightning protection. This thesis represents a contribution to the literature in both medicine and engineering.

Acknowledgements

At the outset, my sincerest gratitude to Professor G Saayman, Head of the Department of Forensic Medicine at the University of Pretoria, friend and mentor, for inspiring and 'sparking' my interest in the field of lightning research.

Next, I would like to thank Professor Mary Ann Cooper for all her guidance, kindness, friendship and support over the years. There hasn't been a week that goes by without our discussing some or other aspect of lightning and/or electrothermal injury.

Many thanks to the late Professor Ralph Anderson who, over a whiskey, sat me down in his house all those years ago and patiently told me the whole story of lightning research in South Africa and beyond.

Special thanks to Dr Chris Andrews and to Dr Ron Holle for their continuous and wise insights and inputs over the years.

Professor Raymond Fish from the University of Illinois deserves a special mention, because he has helped me come to a better understanding of electrothermal injury phenomena.

Thanks to Major Lindsay Smith from the bomb disposal management section of the South African Police Services for sharing his barotrauma library with me.

Thanks to Ian McKechnie for our breakfast sessions which really helped the development this thesis.

Thanks to Debbie Nobelis for the artwork and to Barbara English and Elizabeth Le Sueur for the editing.

Thanks to my examiners who reviewed this work. Thanks for their meticulous and insightful feedback.

Finally, a very special word of thanks to my supervisor, Professor Ian R. Jandrell and his team from the School of Electrical and Information Engineering, University of the Witwatersrand, (N J West, M D Grant, K Nixon, H Hunt and N Jiyane), without whom none of this would have happened!

Dedicated to my family

As Ponocrates grew familiar with Gargantua's vicious manner of studying, he began to plan a different course of education for the lad; but at first he let him go on as before knowing that nature does not endure abrupt changes without great violence.

Rabelais, "The Old Education and the New", Gargantua, Book 1.
Translated from the first French edition into English by Sir Thomas Urquhart of
Cromarty and Peter Antony Motteux, 1653

CONTENTS	PAGE
DECLARATION	3
ABSTRACT	4
ACKNOWLEDGMENTS	5
DEDICATION	6
TABLE OF CONTENTS	7
List of figures and tables	8
Chapter 1 Introduction, background to the problem and literature survey	10
Chapter 2 Previous work published on the subject	28
Chapter 3 Additional evidence discovered through case reports	41
Chapter 4 Confirming the existence of a sixth mechanism of injury	47
Chapter 5 Mimics of the sixth mechanism	70
Chapter 6 Discussion of the results	74
REFERENCES	82
APPENDICES	92

List of figures and tables

1.1 The first mechanism: Direct lightning strike	12
1.2 The second mechanism: Indirect lightning strike	14
1.3 The third mechanism: Side flash	15
1.4 The fourth mechanism: Step voltages	16
1.5 The fifth mechanism: Upward streamer mechanism	18
1.6 Frequency chart of lightning fatality mechanisms	19
1.7 The idealised blast wave form	22
1.8 The sixth mechanism: Lightning explosive barotrauma	26
2.1 McKelvie, Page and Mackerras' experiment	31
2.2 McKelvie, Page and Mackerras' experiment	32
2.3 Structural damage caused to a club house building	35
2.4 Signs of the roof having collapsed	35
2.5 Aircraft nose radome punctured by lightning	36
2.6 Hickman's experiment	37
3.1 Diagrammatic representation of the lightning strike event	42
3.2 Shrapnel wounds noted on victims lower legs	43
3.3 Blast effects noted on the concrete pavement	43
3.4 Traumatic emphysema (pneumomediastinum)	46
4.1 Proposed appearance of sixth mechanism of lightning injury	47
4.2 Gas flowing at a muzzle	49
4.3 Axial view in the direction of the shot	49
4.4 The sixth-mechanism experiment set-up (gels)	53
4.5 The sixth-mechanism experiment set-up	54

4.6 High speed photograph of testing	55
4.7 Smoke node photograph	56
4.8 Incremental permanent cavity formation	56
4.9 Initial testing with soft gelatine blocks (Table)	57
4.10 Initial testing with Corbin's gel (Table)	58
4.10 Initial testing with Corbin's gel (Figure)	59
4.11 Axial view. Corbins gel. 10kV	60
4.12 Axial view. Corbins gel. 18kV	60
4.13 Incremental fissure/fractures in Corbins gel (Table)	61
4.14 The sixth-mechanism experiment set-up (paper)	64
4.15 The wooden box with electrodes (test area)	65
4.16 Polystyrene foam to insulate and clamp paper	65
4.17 Dry paper test. 15kV.	66
4.18 Saline-soaked paper test. 20kV.	66
4.19 Graph showing trend lines of dry, distilled and saline papers.	67
5.1 Bleeding from external auditory meatus.	71
6.1 Proposed Z-configuration Schlieren system.	80
7.1 Table – Independent testing N Jiyane and H Hunt	97
7.2 Table – Independent testing N Jiyane and H Hunt	98
7.3 Table – Independent testing NJ West	99
7.4 Table – 6th mechanism testing on paper West and Blumenthal	100
7.5 Table – Damage approximations, explosive shocks in air	101
7.6 Table – High explosive overpressure constants and consequences	102
7.7 Table – Direct blast effect of explosives: Fatalities and injuries	103
7.8 Table – Human injury in proximity to a small bomb	104

CHAPTER ONE – INTRODUCTION

1.1 Background

"Pathology, (from the Greek *pathos*, meaning 'suffering' and *logos*, meaning 'word') deals with the causes and mechanisms of human disease. For this reason, pathology is one of the basic medical sciences and is vital to the understanding of disease and seeing to its appropriate treatment. It is important to realise that, like medicine, pathology is *not a clearly delineated science*. It owes its development to successive intellectual and technical borrowings from nearby disciplines such as anatomy, physiology, physics, chemistry, microbiology, immunology, genetics, and cell and molecular biology. For this reason, pathology reflects closely the body of knowledge gradually acquired in each of these disciplines" (Damjanov 1996: 1).

Forensic pathology is the study of the diseases and injuries of the community. It is the last stronghold of the autopsy (Saukko, 2004; Mason, 2000; Schwär, 1988; Wright, 1980; Gradwohl, 1976).

Forensic medicine, on the other hand, may be defined as consisting essentially of that body of medical and paramedical scientific knowledge which may be used for purposes of administration of the law (Smith, 1951).

Keraunopathology is the study of the pathology of trauma of lightning on the human and/or animal body.

The medico-legal and forensic perspectives surrounding a lightning strike have been highlighted in the newer literature as early as 1995 (Jumbelic, 1995). A call for improved medico-legal investigation into lightning-related deaths has also been made over the years (Blumenthal, 2006; 2012c).

From a pure keraunopathology point of view, the mechanism of lightning strike may possibly and probably be ascertained after the fact, after careful examination of the testimonial and the physical evidence (Blumenthal, 2012c).

Lightning can be defined as a transient, high-current electric discharge whose path length is generally measured in kilometres. The electric current involved in lightning strikes is direct current (DC) in the order of 30 000 to 50 000 Amps (Uman, 1969).

"Lightning deaths cannot be other than accidental and provide no real problems for the forensic pathologist. Occasionally the nature of the death may be uncertain if a dead body is discovered in the open with no marks upon it. It is well known that injury from lightning is capricious and unpredictable. Two people can stand side by side during a flash and one

may be mutilated and killed while the other is unharmed. The physical damage in fatal lightning strike cases can vary from virtually nil to gross burning, fractures and even tissue destruction" (Saukko 2004:336).

To date, five mechanisms have traditionally been described in the mainstream medical literature regarding lightning injury mechanisms. Briefly, these mechanisms are:

- A direct lightning strike;
- An indirect lightning strike caused by contact with an object such as a pole or a tree that was directly struck; and
- A side flash that could occur from a struck object, such as a tree, to a nearby victim.
- In addition, a person or animal standing near a struck object, or close to a flash of lightning to ground, could be injured by step voltages produced by a lightning current flowing through the resistance of the soil beneath. This earth current can then also flow in another pathway, namely, up one limb and down another of the victim, which could result in injury or even death.
- Also, bodies could become sufficiently charged during the lightning leader development process to cause upward streamers to be initiated from them, leading to injuries.

An understanding of these five mechanisms, together with the keraunopathology associated with these mechanisms, provides the background to this thesis.

These five mechanisms of lightning injury are explained in more detail in section 1.2.

1.2 The five mechanisms of lightning injury

1.2.1 The first mechanism of lightning injury:

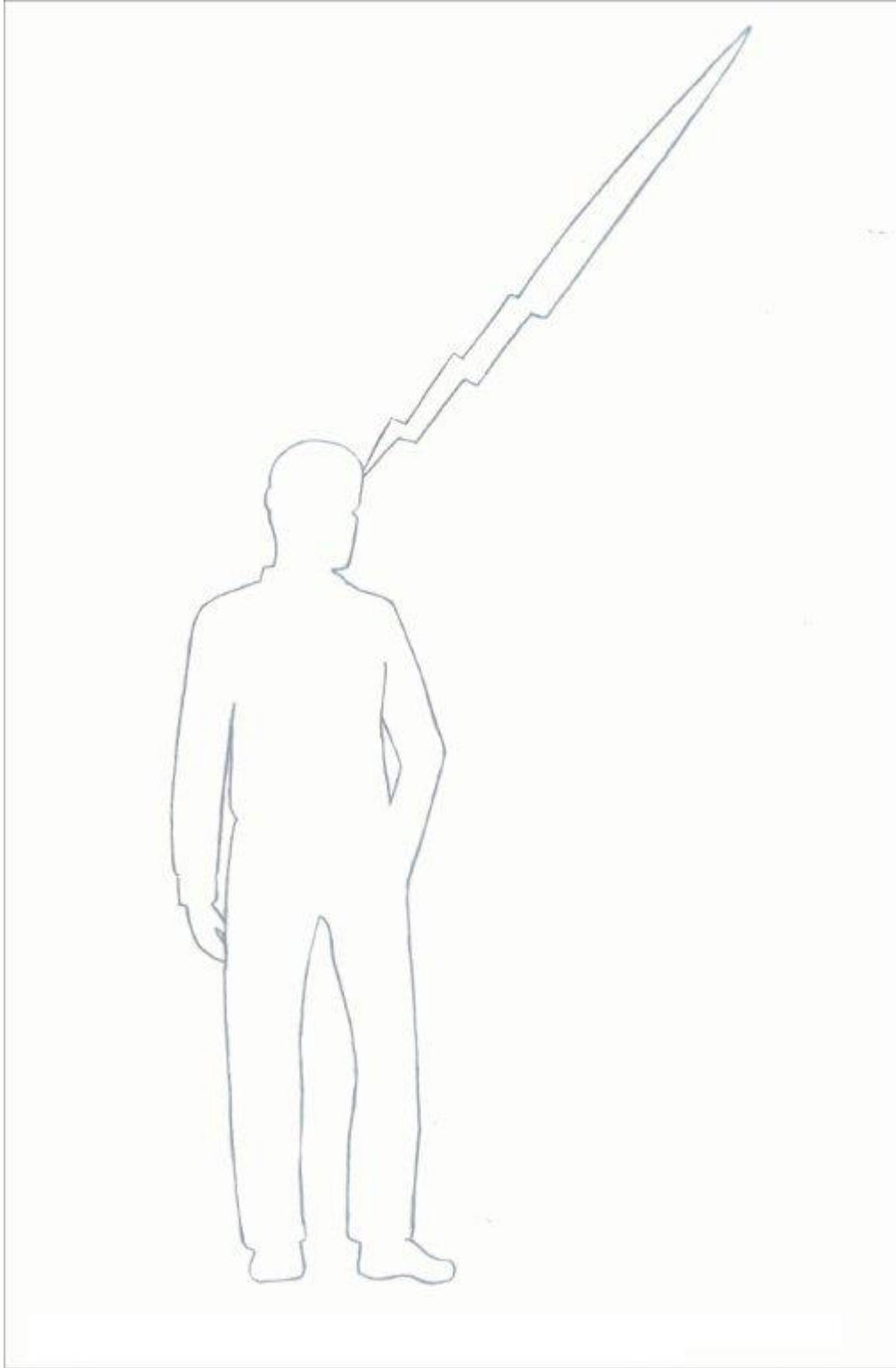

Figure 1.1: The first mechanism of lightning injury: Direct strike.

"A direct strike occurs when the lightning stroke attaches directly to the victim. This is most likely to occur outdoors when a person has been

unable to find a safer location, and probably occurs in no more often than 3% to 5% of injuries. While it is intuitive that direct strike might be the most likely to cause fatalities, this has not been shown in any studies" (Cooper and Holle, 2008, 2010; Auerbach 2012: 75).

The pathology of trauma that one might expect to find in direct lightning strikes is *severe* injuries from increased (direct) energy transmission to the body with severe heat, flame and current effects. It is unlikely that a victim would survive direct lightning strike. Gigantic voltages and amperages are involved when a highly charged thundercloud discharges via a huge arc to the ground.

"The physical damage in fatal cases can vary from virtually nil to gross burning, fractures and tissue destruction. Cutaneous marks may be present, the well-known 'fern-like' or 'arboresque' pattern being much less common than the standard texts suggest... Irregular marks, often linear first-degree burns, may follow skin creases, especially if damp from sweating. These marks may be inches long and generally follow the long axis of the body towards the ground. Frank blistered or charred burns are also present in some cases... The clothing may be torn off and this can sometimes raise the suspicion of foul play if the lightning aspect is obscure. The clothing is typically ripped open as if by an internal explosion, and belts and boots may be similarly ruptured. Burns on the skin may be adjacent to metal objects in or on the clothing. There is often a smell of singeing or burning about the body and its clothing. The hair may be scorched and there is often a head injury, caused either by the lightning strike itself or by falling to the ground" (Saukko 2004: 336).

1.2.2 The second mechanism of lightning injury:

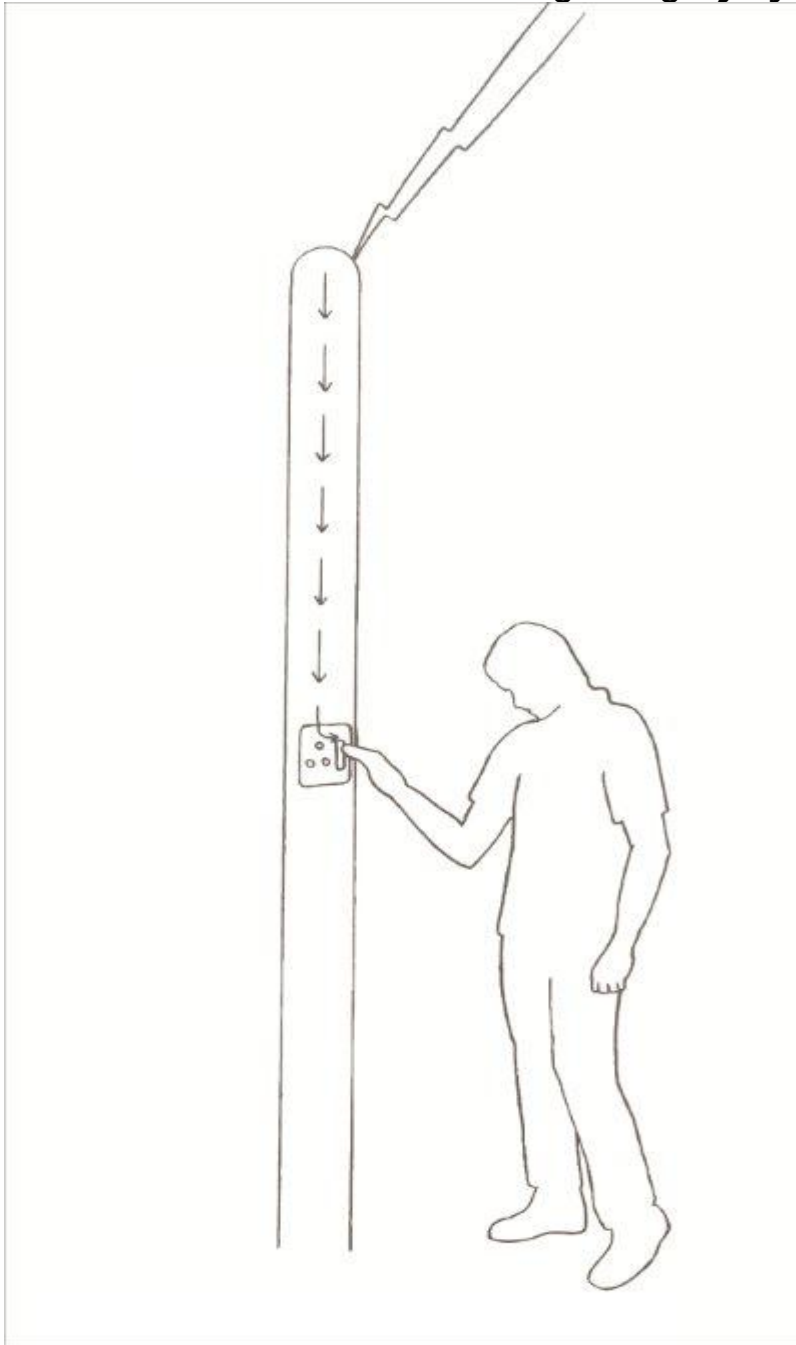

Figure 1.2: The second mechanism of lightning injury: Indirect strike.

“Contact, or touch potential, injury occurs when the person is touching or holding onto an object to which lightning attaches such as wire fencing or indoor hard-wired telephones or plumbing, that transmits the current to the person as shown in Figure 1.2. A voltage gradient is set up on that object from strike point to ground, and the person in contact with the object is subject to the voltage between the contact point and the earth. A current therefore flows through them. Contact injury probably occurs in about 3% to 5% of injuries” (Cooper and Holle, 2008, 2010; Auerbach 2012: 75).

The pathology of trauma one might expect to find in such cases is a 'point of entry' phenomenon where the touch took place (probably producing an electrical-pattern type burn), together with an exit wound. One published report described a telephone-mediated lightning stroke where a woman was on the phone and sustained a lightning injury (Lichtenberg figures – superficial fern-like patterns on the skin) through possible touch potential (Mahajan, 2008; Resnik, 1996). An Australian survey also confirmed three distinct telephone-mediated lightning strike syndromes (Andrews, 1989).

1.2.3 The third mechanism of lightning injury:

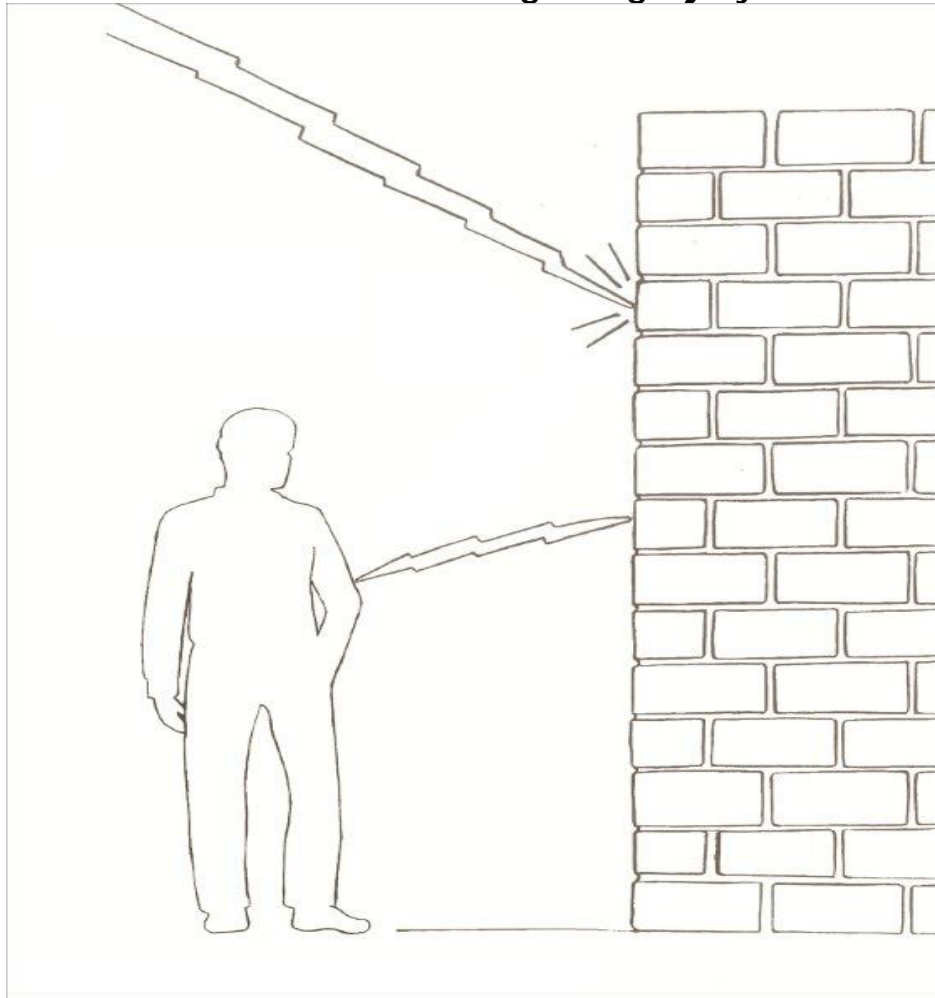

Figure 1.3: The third mechanism of lightning injury: Side flash.

"A more frequent cause of injury, perhaps as much as 30% to 35%, is a side flash, also termed "splash". Side flashes occur when lightning that has hit an object such as a tree or building travels partly down that object before a portion "jumps" to a nearby victim. Standing under or close to trees and other tall objects is a very common way in which people and animals are splashed. Current divides itself between the two or more paths in inverse proportion to their resistances. The resistance of the "jump" path represents an additional path separate from the path to earth from the stricken object. Side flash may also occur from person to person" (Cooper and Holle, 2008, 2010; Auerbach 2012:77).

Owing to a proportion of the energy being 'dumped' on the object first stricken, one might expect to find less severe injuries than one would expect in direct strikes. An inspection of the scene will reveal the pathway of the lightning stroke on the tree or building. In other words, one might find signs on the tree or the wall indicating where the lightning first struck.

To date, there have been two published reports in the literature, demonstrating third mechanism injury (Grant, 2012; López, 2013).

Grant et al. (2012) reported on the multi-disciplinary forensic approach to the lightning caused death of a critically endangered breeding pair of *Tragelaphus eurycerus isaaci* at the National Zoological Gardens, Pretoria, Republic of South Africa.

López et al. (2013) reported on the multi-disciplinary approach to a side-flash lightning incident to human beings in the Basque Country.

Both published reports utilized forensic engineering analysis, including a detailed description of the site geometry and characterisation of the electrical environment including soil and tree impedances.

1.2.4 The fourth mechanism of lightning injury:

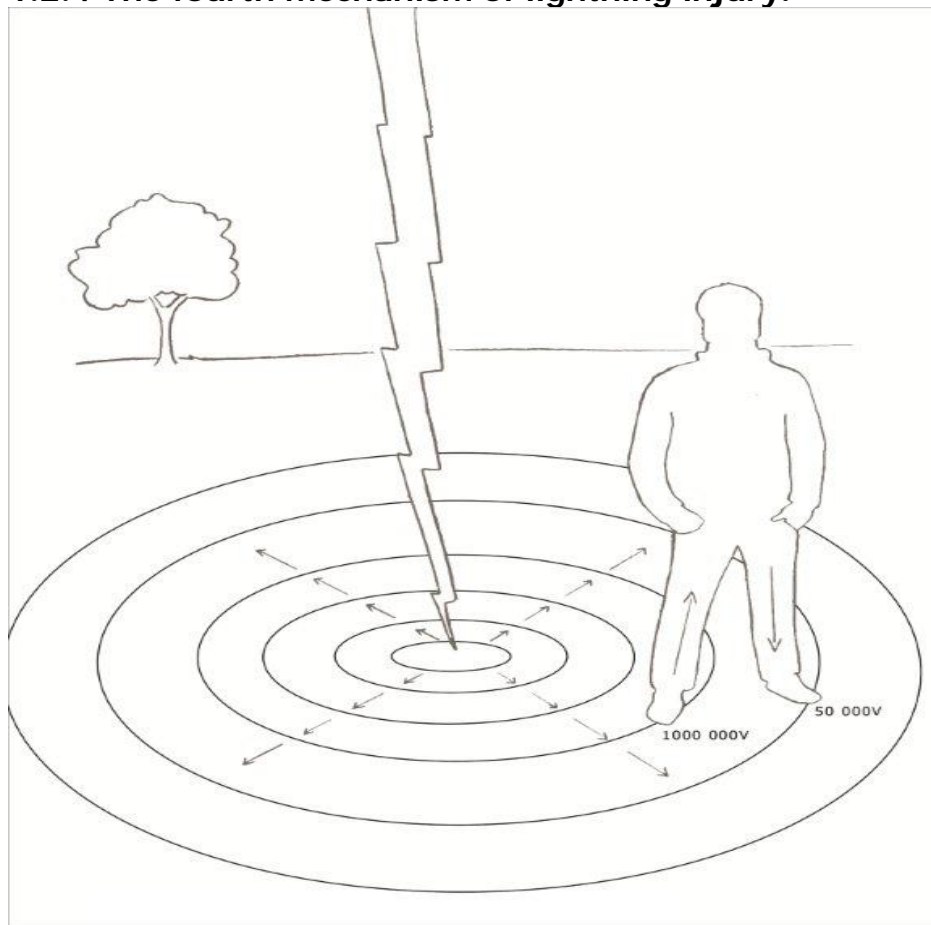

Figure 1.4: The fourth mechanism of lightning injury: Step potential.

"Earth potential rise (EPR), also known as ground current, arises because the earth, modeled ideally as a perfect conductor, is not so in reality.

When lightning current is injected into the earth, it travels through the earth just like it would in any other conductor. The earth has a finite resistance so that voltages are set up in the ground, decreasing in size with distance from the strike point. The voltage (or potential) of the earth is raised, hence the term EPR" (Cooper and Holle, 2008, 2010; Auerbach 2012: 77).

"There are several consequences of EPR. If a person is standing in an area where EPR is active, i.e. near the point of a strike, a voltage difference will appear between their feet and current could flow via the legs into the lower part of the body. This is more significant between front and back legs of animals, where the path is usually longer than in humans and where the heart may be involved along the pathway. Ground current effects are more likely to be temporary, slight and less likely to produce fatalities. However, multiple victims and injuries are frequent" (Cooper and Holle, 2008, 2010; Auerbach 2012: 77).

It is estimated in the literature that this mechanism is responsible for up to 50% or 55% of all injuries associated with lightning (Cooper and Holle, 2010; Auerbach 2012: 77).

"During a lightning strike, the current injected into the ground at the point of strike will flow radially outwards. This current flow will result in a potential difference between two points located in the radial direction. If a person happens to be standing close to a point of lightning strike, this potential difference known as step voltage, appears between his two feet leading to a current surge through the lower body. The current will enter the body through one leg and goes out from the other. In this case, the current does not flow through the heart or the brain. The resulting injuries are usually not severe. However, if the person happens to be sitting or lying close to the point of strike, the magnitude and the path of the current through the body may depend on the way in which the body contacts the ground. This is even more important for a four-footed animal, where current may flow from front leg to back leg with the heart in the pathway" (Cooray 2007: 387).

Regarding the pathology of trauma, one might expect to find *no visible signs* on the victim.

1.2.5 The fifth mechanism of lightning injury:

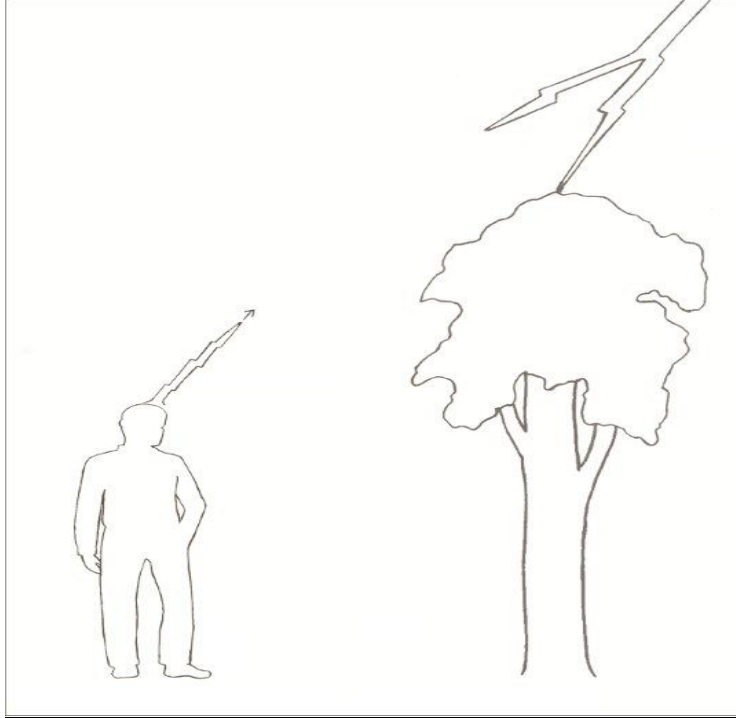

Figure 1.5: The fifth mechanism of lightning injury: The upward streamer mechanism.

"The dangers of upward streamers have been documented (Anderson, 1989, 2001, 2002 and Cooper, 2002). Injury may occur when a victim serves as the conduit for one of the usually multiple upward leaders induced by a downward stepped leader and its field. Upward streamers occur even when there is no attachment between them and the stepped leader. While one might think that these are weak in energy compared to the full lightning strike, they may carry several hundreds of amperes of current which can be transmitted through or around the victim. Upward streamer injury is probably a much underestimated mechanism of injury, and may account for as much as 10% to 15% of injury cases" (Cooper and Holle, 2008, 2010; Auerbach 2012: 78).

The pathology of trauma one might expect to see in such cases is similar (flame, heat and current effects) as in direct strikes.

1.2.6 Comments on lightning injury statistics:

Most critical lightning incidents tend to occur in rural areas, far away from academic institutions (Holle, 2005).

The thorough investigation of a lightning fatality victim is a *labour-intensive exercise*, requiring the input of multiple divergent disciplines, including forensic pathologists, clinicians, electrical engineers, meteorologists and climatologists, to name but a few (López, 2013; Grant, 2012; Blumenthal 2012b).

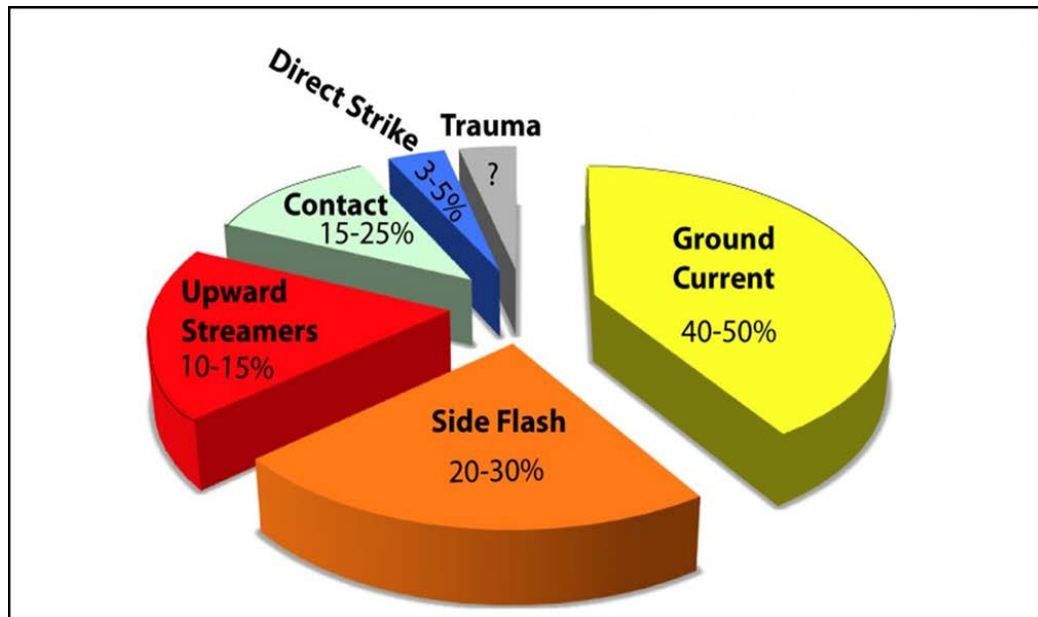

Figure 1.6: This chart shows the frequencies of the primary lightning fatality mechanisms (Cooper & Holle, 2008; Auerbach 2012: 77).

The above percentages of the different lightning injury mechanisms involved in lightning-related injuries and deaths (direct 3% to 5%, indirect 15% to 25%, side flash 20% to 30%, step potential 40% to 50% and the fifth mechanism 10% to 15%) arise from the *clinical literature* and should therefore be read *cautiously* and with some degree of scepticism as these percentages have not been thoroughly and scientifically verified, for example through post-mortem examination.

Aforementioned needs to be kept in mind when considering the reliability and credibility of lightning injury statistics (Blumenthal, 2012c).

1.2.7 Delimitation of field/scope of the study:

Evidence suggests a further lightning injury mechanism, which for purposes of this thesis, shall be termed the *sixth mechanism* of lightning injury.

This sixth injury mechanism has been known to exist for some time; although has existed under different conceptual names in the literature (Lee, 1982; Lee, 1986; Lee, 1987; Rakov & Uman, 2005).

On the basis of observations from the field of forensic pathology, together with supportive data and experimental evidence from the field of electrical engineering, the existence of an umbrella term, namely 'the sixth mechanism of lightning injury' will be proposed, reviewed and studied in greater detail.

What follows is a scholarly work which will hopefully advance the understanding of the damaging effects of lightning and will contribute to both the medical and the engineering literature.

1.3 Unusual lightning injury pathology

The five known lightning injury mechanisms explain the vast majority of lightning-related injuries: direct flame, heat and current effects (Murty, 2009). However, these mechanisms do not explain *all* lightning-related injuries.

Flame, heat and current effects suggest that lightning injury is chiefly *electrical* and/or *thermal* in nature. While electrothermal phenomena explain the vast majority of injuries observed in lightning strike victims, including cardiac (Zack, 1997), electrothermal (Wetli, 1996), and at least some of the neurological injuries observed (Silbergleit, 1988), a review of the literature on lightning shows an interesting injury phenomenon which is difficult to explain with contemporary electrical and thermodynamic injury models and which has become a topic of debate. The phenomenon includes torn and tattered clothing (Anderson, 1989; Blumenthal, 2003), fractures (Kannan, 2004), rupture of shoes, traumatic perforation of tympanic membranes (Bellucci, 1983; Soltermann, 1991; Gordon, 1995; Jones, 1991; Bergstrom, 1974; Weiss, 1980; Kristensen, 1985; Glunic, 2001; Redleaf, 1993; Wright, 1974) lung contusion and haemorrhage (Soltermann, 1991) and even pneumomediastinum (Halldorsson, 2004).

In two peer-reviewed, retrospective descriptive studies by the author, unusual findings were noted, which did not quite fit in with the electrothermal injury models (Blumenthal, 1997, 2000). Unusual findings regarding the *pathology of trauma* of lightning strikes were noticed on some of the victims:

1.3.1 The first retrospective descriptive paper (Blumenthal, 2003):

- In this study 20 of the 38 lightning fatality cases (52%) showed features consistent with associated blunt-force injury (including contusions, abrasions, etc). Fractures were encountered in two cases (fractured spine and fractured clavicle, respectively).
- Rupture of the tympanic membrane was mentioned in one case.

1.3.2 The second retrospective descriptive paper (Blumenthal, 2005):

- In this study 23 of the 52 lightning fatality cases (44.23%) had some form of associated blunt force trauma.
- Ruptured eardrums were positively reported in two cases (3.85%).

This thesis examines the problem of finding *high-order explosive bomb blast* signs on lightning strike victims. In other words, there seems to be a sub-category of lightning strike victims who display features suggestive of explosive barotrauma.

Furthermore, testimonial evidence from lightning strike survivors is similar to those who have been exposed to stun grenade explosion. Survivors of close lightning flashes typically report an intensely loud "bang", sufficient to cause deafness, tinnitus, and inner ear disturbance. Survivors also

experience disorientation, confusion and loss of coordination and balance. Unconsciousness has also been reported.

To date, lightning explosive barotrauma has not been adequately addressed in any of the authoritative forensic texts (Saukko, 2004; Mason, 2000; Schwär, 1988; Elsayed, 2008).

1.4 Lightning explosive barotrauma

1.4.1 Background

In the textbook on explosions and blast related injuries, edited by Nabil M Elsayed and James L Atkins (2008), there is no mention of blast wave injuries from a lightning strike.

Explosives may be categorised as either low-order explosives or high-order explosives. Low-order explosives (gunpowder) release energy through a process called “deflagration”, which occurs at subsonic speeds, and is essentially “burning” of the material. High-order explosives (C4, TNT) detonations result in the rapid transformation of the explosive material into a highly pressurised gas, which releases energy at supersonic speeds (Langworthy, 2004; Wightman & Gladish, 2001; Horrocks, 2001; Cullis, 2001).

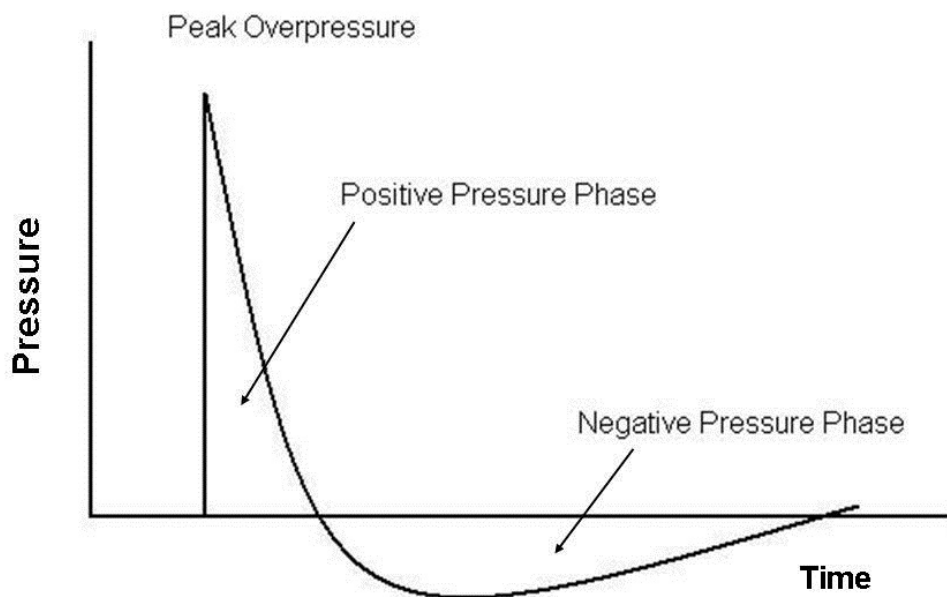

Figure 1.7: The idealized blast waveform, adapted from the work of Nabil M Elsayed and James L Atkins (2008).

Explosions are physical phenomena that result in the sudden release of energy; they may be chemical, nuclear or mechanical. This process results in a near-instantaneous pressure rise above atmospheric pressure as demonstrated by the idealised blast waveform shown in Figure 1.7. This positive pressure peaks (“overpressure”), and then falls rapidly into a longer negative pressure phase before subsequently returning to the baseline. This positive pressure rise compresses the surrounding medium (air or water) and results in the propagation of a blast wave, which extends outward from the explosion in a radial fashion (Langworthy, 2004; Cullis 2001). As the front or leading edge of the blast wave expands, a decrease in pressure follows it with the development of an “underpressure” (negative) wave (Sasser, 2001).

Elsayed described five basic types of blast-related injury patterns in the literature:

“Primary blast-related injuries are characterised by anatomical and physical changes that result from the blast wave impacting the body’s surface and tissues, and affect primarily gas-containing structures. Secondary blast-related injuries result from flying debris (e.g., glass, concrete, wood) and bomb fragments striking the victim, resulting in penetration or less commonly, blunt force trauma. Tertiary blast-related injuries result from the victim being thrown by the blast wind (forced super-heated air flow), which can lead to fractures, traumatic amputations, closed and open brain injuries or other blunt or penetrating trauma. Quaternary blast-related injuries are all explosion related injuries, illnesses, or diseases not due to primary, secondary or tertiary mechanisms and include exacerbation or complications of existing conditions. Examples include thermal or chemical burns, radiation exposure, or inhalation injury from exposure to dust or toxic gases. Any injury caused by collapse of buildings (falling masonry) or nearby structures can be included in this category. Quinary blast-related injury refers to the hyperinflammatory state out of proportion to the injury sustained (Mayo & Kluger, 2006), recognising that most victims of terrorist bombings have injuries caused by multiple mechanisms, referred to as a multidimensional injury” (Elsayed 2008: 13).

To be injured by a blast, one has to be in the immediate vicinity of the explosion, within about a metre or so (Mason, 2000). About 100 psi (690kPa) is the minimum threshold for serious damage to humans (Saukko, 2004). Blast lung, bowel contusion and tympanic membrane rupture, some of which may be found in some cases of lightning injury, are typically found in cases of direct transmission of a detonation shockwave (Mason, 2000).

It is customary to use Marshall’s triad when one considers the pathology of trauma of bomb explosions (Marshall, 1976). The triad includes punctate-bruises, abrasions and small lacerations - all of which are typically found in an explosive bomb blast. Many similarities exist between injury patterns seen in lightning and concussive blast-type injuries. These similarities will be demonstrated and expanded upon later in this thesis.

A blast consists of a wave of compression passing through the air. The velocity of the shock wave depends on the distance from the epicentre, being many times the speed of sound at the start, but rapidly decreasing as it spreads out. The magnitude of the blast varies with the energy released and also the distance from the epicentre, the intensity obeying the inverse square law.

“An explosion classically gives rise to a narrow wave of very high pressure which expands concentrically from the seat of the explosion at about the speed of sound. The pressure is exceptionally high at the front of the wave but decreases towards its rear and becomes a slight negative pressure, or partial vacuum, before the wave is complete. Such a wave will temporarily engulf a person as it moves through him/her” (Mason 2000: 85).

Depending on what literature one reads, there is also data from weapons tests and blast studies to assess the effect of blast over pressure on structures and people. This data provides some guidance on the possible effects of explosions (Zipf and Cashdollar, 2007; Glasstone and Dolan, 1977).

1.4.2 A sixth mechanism of lightning injury

We know that there is a pressure blast wave around lightning’s luminous channel. We have known about it since the time of Gaius Plinius Secundus, better known as Pliny the Elder (23 AD – 79 AD) (Critchley, 1934).

One can hear thunder from as far away as 25km (Uman, 2003), which means that there is a tremendous amount of energy involved in the generation of thunder. However before thunder exists, there is a pressure blast wave. This pressure blast wave is caused by the super-heating of air (Charles’ law) around the lightning bolt, which travels at super-sonic speeds. It is this super-sonic blast wave which decays, within metres, and transforms into thunder. Many people think that lightning injures humans chiefly due to its electricity and heat. While this is true for the vast majority of lightning-related deaths and injuries, the accompanying pressure blast wave is also suspected to cause some serious harm.

A review of the forensic pathology literature seems to place little significance and less emphasis on explosive barotrauma as an injury mechanism with regard to lightning strike (Saukko, 2004; Mason, 2000).

None of the aforementioned five lightning injury mechanisms can adequately and convincingly explain some of the more curious lightning injury patterns seen on lightning strike victims.

The contemporary thinking is that lightning current causes electrothermal injury patterns on victims (direct flame, heat and current effects). Why, then, does one see blunt force trauma injuries (fractures, lacerations,

abrasions, etc) and explosive-type injuries (torn-and-tattered clothing, ruptured ear drums, etc) on victims? Such findings have not been as thoroughly addressed in any of the more authoritative forensic pathology textbooks on the subject of keraunomedicine and keraunopathology (Saukko, 2004; Mason 2000).

Kitigawa, et al. (1985) studied the nature of lightning discharges on human bodies. Various lightning-simulating discharge experiments were performed using dummies, rabbits and other small animals. On the basis of these experimental studies, the authors performed detailed investigations of human lightning accidents for ten years. There was however minimal emphasis placed on lightning blast-related pathology in their paper (Kitigawa, 1985).

Blast-related injury patterns have been observed on victims of lightning strikes. The findings on the bodies of lightning victims are very similar to those of victims exposed to high-order explosives. "Primary blast injury is often manifested as ruptured tympanic membranes, whereas tertiary blast injury may present as blunt trauma when the victim falls or is thrown" (Ritenour, 2008: 587).

"The pressure or shock wave (sudden explosive expansion of air around the lightning channel) has been described as the cause of blunt trauma injury (when a person is thrown to the ground), temporary deafness due to rupturing of the eardrums, or the bursting of soft tissue and fractures typically in the feet" (Elsom, 2001: 327).

Numerous presentations, congresses, peer-reviewed publications and book chapters have surrounded and led up to the development of this thesis (please refer appendices A, B, C & D).

The proposed umbrella term, 'the sixth mechanism of lightning injury', will be shown to be the most plausible, if not the best explanation as to the pathogenesis of aforementioned injuries.

The first part of this thesis will critically examine all that is known about lightning's 'pressure-shock wave'. Could it, for example, adequately and convincingly explain aforementioned curious injury phenomena? Secondly, if this blast wave does exist, what does it look like?

This remainder of this thesis will focus on answering two main questions, namely within what range is one at risk; and what is the risk of lightning's pressure blast wave.

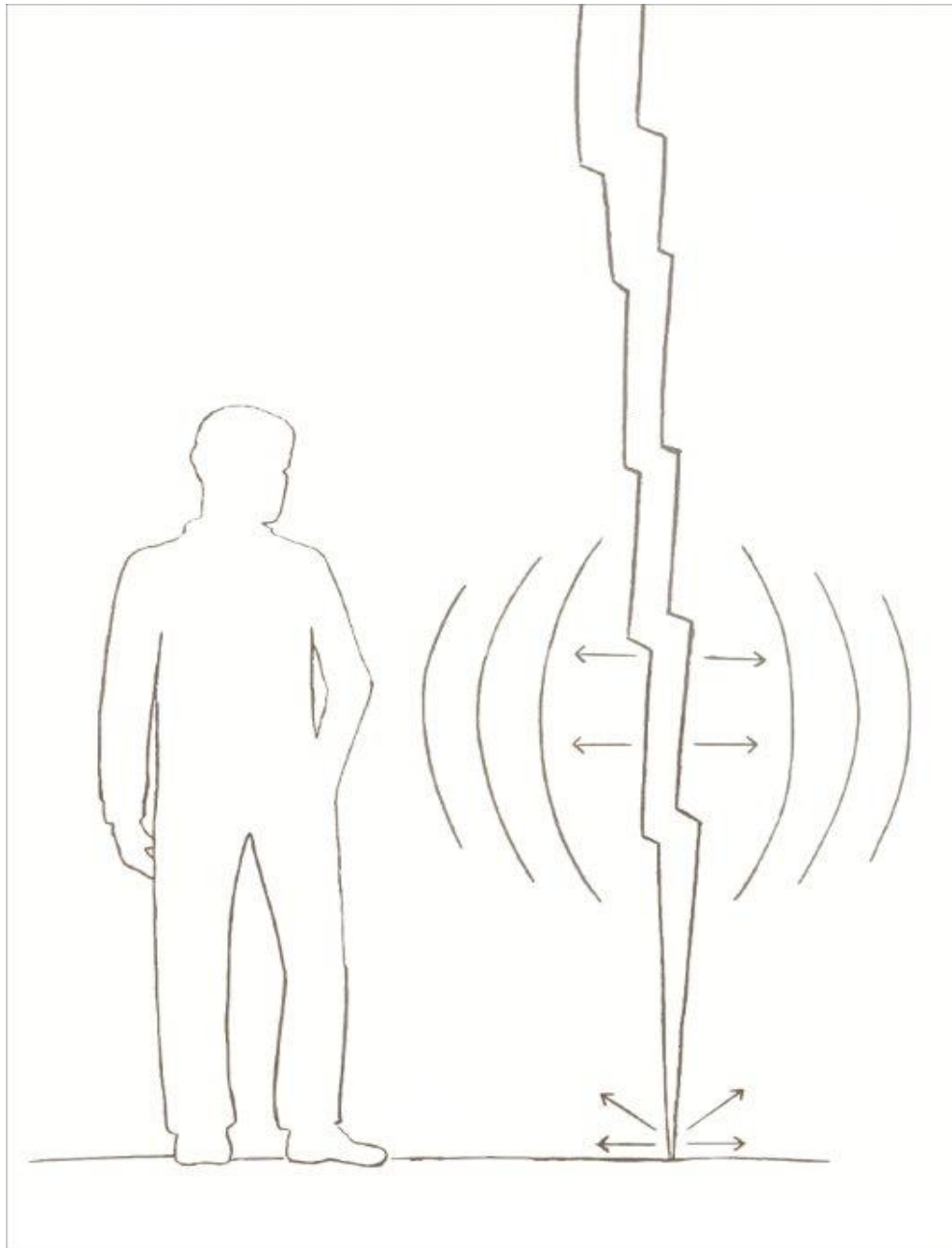

Figure 1.8: The sixth mechanism of lightning injury: Lightning explosive barotrauma, imagined as a 'pressure-shock wave' immediately surrounding lightning's luminous channel.

1.4.3 Research Objectives

The research objectives raised by this hypothesis are:

1. An in-depth look at lightning explosive barotrauma. Could a 'pressure-shock wave' immediately surrounding lightning's luminous channel adequately and convincingly explain aforementioned curious injury phenomena?
2. If this blast wave does exist, what does it look like?
3. And, within what range is one at risk and what is the risk?

The importance of this study and the implications of answering these three objectives will be addressed in this thesis.

CHAPTER TWO – SURVEYED LITERATURE

Chapter one concerned itself with the introduction and background history to the problem. Chapter two will chiefly focus on work previously published in this arena.

2.1 Lightning explosive barotrauma

There is a limited literature published on lightning explosive barotrauma. The following paragraphs represent the multi-disciplinary work published on this subject, in chronological order, to date:

2.1.1 The ancient literature

The Roman author Pliny noted that *“the man who sees the lightning flash and hears the thunder, is not the one struck”* (Critchley 1934:69). Gaius Plinius Secundus (AD 23 – August 25, AD 79), better known as Pliny the Elder, was a Roman author, naturalist, and natural philosopher. In his *Naturalis Historia*, published circa AD 77–79, he had observed a natural injury phenomenon which possibly suggests toward lightning explosive barotrauma.

2.1.2 The work of Brode (1956)

The results of a calculation of the blast wave resulting from the explosion of a sphere of air initially at rest and at standard sea-level density but at 20 000 atmospheres pressure. These results were presented in graphical form, showing the variations of overpressure, density, particle velocity, temperature and dynamic pressure as functions of space and time. Shock values of these parameters, total impulses, positive durations, and shock arrival times were illustrated. Please note that this research was based on overpressure calculations for spherical shock waves (Brode, 1956).

2.1.3 The work of Malan (1963)

Malan touched on the concept of lightning explosive barotrauma in his book, *The Physics of Lightning* (1963):

“A further review of the literature on lightning reports that thunder consists of a roughly cylindrical initial pressure shock wave at the lightning channel in excess of 10 atmospheres. The shock wave rapidly decays to a sound wave within metres. The pressure wave – shock propagation – sometimes causes exterior and interior damage to structures. There are multiple well-documented reports of trees being split apart, blast holes in the ground and flying masonry” (Malan 1963: 164).

The explosive effects of lightning on trees and reinforced concrete were discussed, and under the heading of Explosive Effect:

“Should the heavy current of a lightning flash pass through a confined space, the heated air is not free to expand and will exert a pressure on

the walls of the cavity. The larger the cavity, the smaller the excess pressure, since only part of the air in a large cavity will be heated. When a lightning flash is incident on rocky soil the electric current tends to follow the interstices between the rocks or cracks, which are filled with moist soil. Rocks may be split asunder or thrown aside with explosive violence" (Malan 1963: 164).

Personal communication between Muller Hillebrand and DJ Malan (1963):

"Muller Hillebrand has carried out detailed studies of the effects produced by lightning on the rocky soils of Sweden. He quotes one occasion where lightning struck a pine tree and from there ploughed branching furrows in the ground. The total length of the furrows was 250 m, and in one spot there was a crater-like hole 2 m in diameter and 75 cm deep. Rocks of up to half a ton in weight were dislodged and trees uprooted. The total volume of stones and earth cast aside amounted to 25 m³ or the equivalent of 70 tons weight. He estimated that about 200 kg of high-explosive T.N.T. would have been required to produce the same effect as the lightning flash" (Malan 1963: 164).

2.1.4 The work of Uman, Cookson and Moreland (1970)

Uman, Cookson and Moreland (1970) published a paper on a shock wave from a four-meter spark.

"The shock wave emitted by a 4-m spark of energy 2×10^4 J was measured at distances from spark midgap of between 0,34m and 16,5m. Close to the spark, a single dominant shock wave was observed; farther from the spark, a number of significant shock waves (generally 3 or 4) were observed. For distances less than 2m, both the shock overpressure and the duration of the overpressure were between a factor of 1.5 to 5 less than predicted by cylindrical shock-wave theory. The discrepancies between the experimental data and cylindrical shock-wave theory were partially explained by consideration of the spark channel tortuosity" (Uman 1970: 3148).

2.1.4.1 Basis for the sixth mechanism experiments (Uman 1971)

Previous investigations (Uman, 1971) established that the cloud to ground lightning return stroke possesses very similar characteristics to the long electrical spark. Hence the majority of knowledge related to lightning parameters has been derived by 'scaling up' the equivalent information obtained during experimentation with the use of long linear electrical discharges generated under laboratory conditions. This concept is central to this thesis and forms the basis of the sixth mechanism experiments which will be discussed in Chapter 4.

2.1.4.2 The work of Hill (Hill, 1971)

Hill's work (1971) for a 30kA lightning strike showed the following: 40 atmospheres (4053 kPa) at 0,75cm radius from the stroke channel. 29 atmospheres (2938.43 kPa) at 1,1cm radius from the stroke channel. 19

atmospheres (1925.18 kPa) at 2cm radius from the stroke channel. 9 atmospheres (911.93 kPa) at 4.1cm radius from the stroke channel. This showed a near inverse relationship between the pressure and the distance (Lee, 1986: 416). Calculations by Hill therefore show that the overpressure within a few centimeters of the lightning channel can reach about 10-20 atmospheres (1013 kPa to 2026 kPa).

2.1.5 The work of Plooster (1968, 1970)

“The generation of cylindrical shock waves by release of energy along a line in a gas has not been as thoroughly studied as the analogous point-source spherical wave problem. Yet there are a number of phenomena, both natural and artificial, which closely resemble line disturbances. Artificial line sources include exploding wires, long explosive charges, electric sparks, and supersonic aircraft or projectiles. The outstanding natural phenomenon being the lightning discharge” (Plooster 1970:2665).

Plooster (1970) studied the cylindrical pressure wave resulting from instantaneous energy release along a line in a quiescent atmosphere by numerical integration of the equations of gas dynamics. Atmospheres obeying both the ideal gas law, and a realistic equation of the state for air at high temperatures, were employed. The effects of varying the initial distribution of mass and energy in space were investigated. The computations were carried well into the weak shock region, and agreed well with asymptotic solutions (a mathematical analysis for describing a limiting behaviour) for very strong and very weak shock waves. The effects of deviations from the initial assumptions of the strong shock asymptotic solutions were also addressed. An approximate equation for the radial dependence of shock strength, applicable to most of the numerical solutions, was presented.

Air behaves as an ideal gas only over a limited temperature range. To obtain an estimate of the effects of real gas properties on the propagation of cylindrical blast waves, a simplified equation of state had to be devised. Real air is primarily a mixture of Nitrogen and Oxygen in the molar ratio 0,788 N₂ : 0,212 O₂. Since other gases (Ar, H₂O₂, CO₂, etc.) are present in much smaller proportions, Plooster chose to neglect them and represent air as a mythical diatomic gas Air₂. Plooster's model also grossly misrepresented the thermodynamic properties of real air in the temperature range 3000-9000^o K.

For a pressure measurement at a given radial distance, a length of Primacord in excess of twice this distance was suspended horizontally, about 2m above the ground, between two masts. A pressure transducer (Kistler quartz piezoelectric gauge, model 603A) was mounted at the same height along the perpendicular bisector of the explosive charge. The signal from the second transducer, placed well to the side of the first and somewhat closer to the charge, was used to trigger an oscilloscope sweep just prior to the arrival of the signal from the measuring transducer.

Attempts were made to measure shock overpressure at distances ranging from 11,4 cm to 1085 cm from the charge.

Plooster's experimental measurements of shock strengths from detonation of long high explosive charges were shown to be in relatively good agreement with the numerical solutions.

2.1.6 The work of Page, McKelvie and Mackerras (1977, 1980)

In 1980 a paper was presented at the 7th Australian Hydraulics and Fluid Mechanics Conference entitled 'Strength of Shock Waves produced by Electrical Discharges' (McKelvie, 1980). The paper described an experimental study of the shock wave radiating from an electrical spark discharge in atmospheric air. Further measurements of this type have been reported by Page and McKelvie (1977). Of particular interest was the proportion of the total energy deposited into the discharge channel that was related via blast wave theory to the pressure disturbance propagating away from the channel. McKelvie's (1980) paper described a measurement of the electrical and gas dynamic parameters describing the acoustic radiation from a laboratory spark discharge in which the problems associated with earlier measurements were avoided. This was achieved by using a unique fibre-optic link to permit an electrically isolated pressure transducer to be placed very close to the discharge channel as shown in figures 2.1 and 2.2, and careful treatment of the channel tortuosity and the various dissipative elements in the electrical discharge circuit.

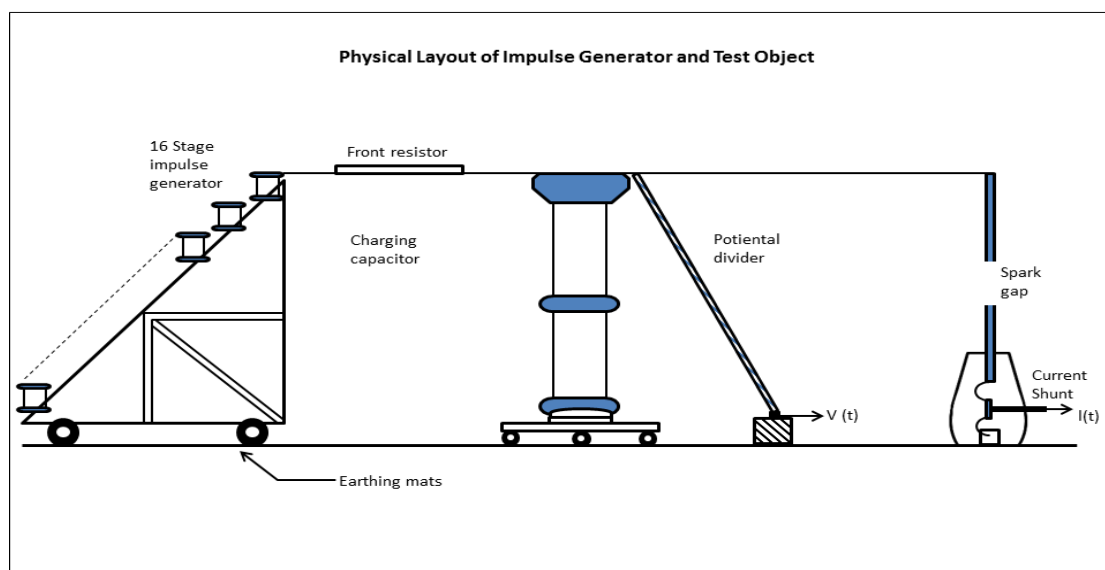

Figure 2.1: The experimental layout of McKelvie, Page and Mackerras' experiment. (7th Australasian Hydraulics and Fluid Mechanics Conference, Brisbane, 18-22 August, 1980).

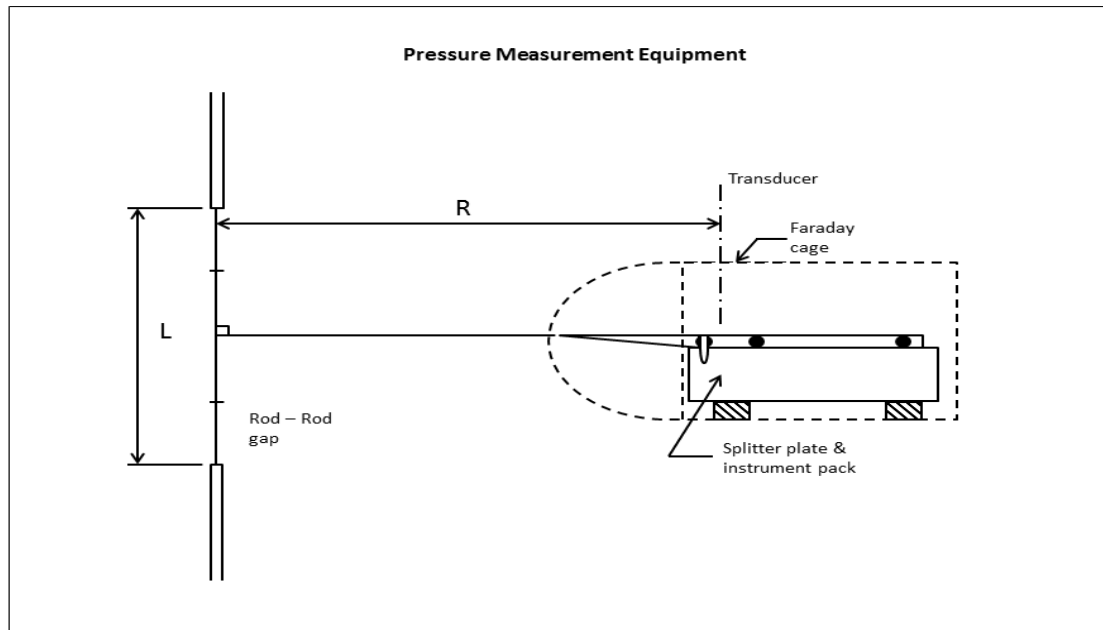

Figure 2.2: The experimental layout of McKelvie, Page and Mackerras' experiment. (7th Australasian Hydraulics and Fluid Mechanics Conference, Brisbane, 18-22 August, 1980).

McKelvie's results verified that the propagation mode of the blast wave from a linear spark discharge in air was indeed cylindrical. Pressure records were taken at radii from 12cm to 1 metre, from a 1 metre spark discharge for energy levels up to 100 J. Allowing for error limits, the results indicated that the proportion of the total electrical energy input that appeared as shock wave energy (acoustic efficiency) ranged from 30 to 75 percent (McKelvie, 1980).

The paper of McKelvie, Page and Mackerras (1980) definitely has its strengths and represents one of the few experiments in the literature using electrical and gas dynamic parameters to measure strength of shock waves produced by electrical discharges. However, it falls short of answering the forensic pathology questions posed in this thesis.

If the research questions are 'If the blast wave does indeed exist, what does it look like?' and 'Within what range is one at risk and what is the risk?' then clearly, more work would have to be done in this field and a newer methodology would have to be developed.

2.1.7 The work of Lee (1986, 1987)

Ralph H Lee (Lee, 1986) researched lightning protection of building roofs and other limited-strength structures.

"The shattering effect attributed to lightning is due to lightning's secondary effect- the pressure impulse of air heated by the lightning. At distances over a few tens of feet, we know this as thunder, but as less than 10-20ft, this pressure can be great enough to destroy many man-made structures. By combining results from several sources, it is possible

to determine the intensity of this pressure from the stroke current magnitude and the distance from the stroke terminal to the susceptible structure" (Lee 1986:416).

"Therefore a 20 000 Amp peak stroke would exert a pressure of 150 lb/ft² (7.18 kPa) on the roof at the base of the terminal" (Lee 1986:417).

Lee also researched pressures developed by arcs (Lee, 1987).

"Along with the flash burns caused by electric arcs, nearby personnel may sustain injuries from falls and collisions if and when they are propelled by the pressure developed by the arcs" (Lee 1987:760).

Lee's lightning work chiefly focussed on *man-made structures* and did not specifically address on the risks posed to human bodies (Lee, 1986).

2.1.8 The work of Sellier and Kneubuehl (1994)

Although, dealing more with projectiles and firearms, Sellier and Kneubuehl addressed the concept of shock waves in gels which is central to this thesis and which forms the basis of the 2012 sixth mechanism experiment which will be discussed in Chapter 4.

"A shock wave is a special type of sound wave (acoustic wave) that runs through a medium at a certain velocity, depending upon the material and the temperature. The velocity of the shock wave depends on the distance from the epicentre, being many times the speed of sound at the start but rapidly decreasing as it spreads out. The magnitude of the blast varies with the energy released and also the distance from the epicentre, the intensity obeying the inverse square law" (Sellier and Kneubuehl 1994:281).

2.1.9 The work of Rakov & Uman (2003)

Rakov and Uman (2003) describe the formation of the shock wave in their book *Lightning – Physics and Effect*, which explains little appreciated forces that can occur with lightning:

"The return stroke heats the channel created by the preceding stepped or dart leader from nearly 10,000K to near 30,000K or more in several microseconds or less. Such a channel overpressure will result in an expansion of the luminous channel and the formation of a shock wave that propagates outward and eventually beyond the luminous channel, which attains pressure equilibrium with the surrounding atmosphere within tens of microseconds. The shock wave differs from the acoustic wave (thunder) in that it compresses and heats the air and, as a result, propagates at supersonic speeds. The initial propagation speed of the shock wave is probably about 10 times the speed of sound. After the bulk (probably 99%) of the energy delivered to the shock wave has been expended in performing thermodynamic work on the surrounding atmosphere, the shock wave is transformed, within a few meters or less from the lightning

channel, into an acoustic wave that propagates at the velocity of sound. Thus, the heated-channel thunder-generation mechanism involves the production and evolution of the shock wave, which is typically characterized by its pressure as a function of radial coordinate at different instants of time" (Rakov & Uman 2003: 378).

2.1.10 The work of Cooray et al. (2007)

Cooray *et al.* (2007) went further to describe the shock waves which may interact with the body in various ways:

"...injuries can also be caused by shock waves created by the lightning channel. During a lightning strike, the channel temperature will be raised to about 25,000 K in a few microseconds and as a result, the pressure in the channel may increase to several atmospheres. The resulting rapid expansion of the air creates a shock wave. This shock wave can injure a human being located in the vicinity of the lightning flash. The pressure associated with the shock wave decreases with the distance rapidly, so that the shock wave can injure a human being located in very close vicinity of the lightning flash only" (Cooray 2007: 387).

"...This rapid heating leads to the creation of a shock wave in the vicinity of the channel. As mentioned previously, the shock wave associated with the lightning flash may reach overpressures of 10-20 atmospheres in the vicinity of the channel. In addition to causing damage in the ear and eyes, this shock wave can also cause damage to other internal organs such as the spleen, liver, the lungs, and the bowel tract. Moreover, it may displace the victim suddenly from one place to another causing head and other traumatic injuries. Indeed, as well as appraising a victim for specific lightning caused injuries, one must always have in mind, associated trauma. In one situation, the victim received fractures of the facial bones during a lightning strike. At the time of strike, he was wearing a helmet and the damage may have been caused by the intense pressure created by a discharge that resulted during the passage of the lightning current from the helmet to the head across the layer of gas lying between the head and the helmet" (Cooray 2007: 392).

"One can also receive blunt injuries from material ejected from the object that is being struck. For example, when lightning strike trees, the trunk of the tree can explode sometimes and the splinters can cause injuries in those standing in the vicinity. One can also receive blunt injuries from flying objects, also inside buildings. During a lightning strike to an unprotected building, the central power distribution switches, television sets and antenna cables may explode causing injuries. Trauma may also be associated with falls from a region (e.g. a cliff) in which a victim finds himself" (Cooray 2007: 392).

2.1.11 The work of McKechnie & Jandrell (2008)

The case studies reported by McKechnie and Jandrell are important to this thesis and form the basis of the argument for the sixth mechanism. Their reports describe the popping of nail-supported drywall away from horizontal and vertical wooden studs inside houses and broken glass windows (McKechnie, 2008).



Figure 2.3: Structural damage to a club house due to direct lightning strike (McKechnie and Jandrell, 2008).



Figure 2.4: Signs of a roof having collapsed. Structural damage caused to a club house building as a result of direct lightning strike (McKechnie and Jandrell, 2008).

2.1.12 The work of Plumer (2012)

Plumer (2012) reported on an aircraft nose radome being 'punctured' by lightning. The focus of Plumer's research was electric fields and not on barotrauma.

The 'punctured' radomes however are important to this thesis and also form the basis of the argument for the sixth mechanism.



Figure 2.5: *Photograph: Aircraft nose radome punctured by lightning (American Airlines photo).*

2.1.13 The work of Hickman (1999- 2012)

The work of Hickman entails solid dielectric breakdown phenomena.

The careful and methodical development of this hypothesis requires an explanation as to why lightning explosive barotrauma is not evident in a certain experimental setting. To this end, Captured Lightning® sculptures and the theory of solid dielectric breakdown requires discussion at this point.

Solid dielectric breakdown phenomena have been studied for over a decade (Hickman, 1999-2012). Hickman's production runs represent the closest experiment to the '2012 sixth mechanism experiment', in that both use currents passing through solid, block-like structures. Further details on Hickman's experiments may be found on their website (Hickman, 2013). Please refer figure 2.6.

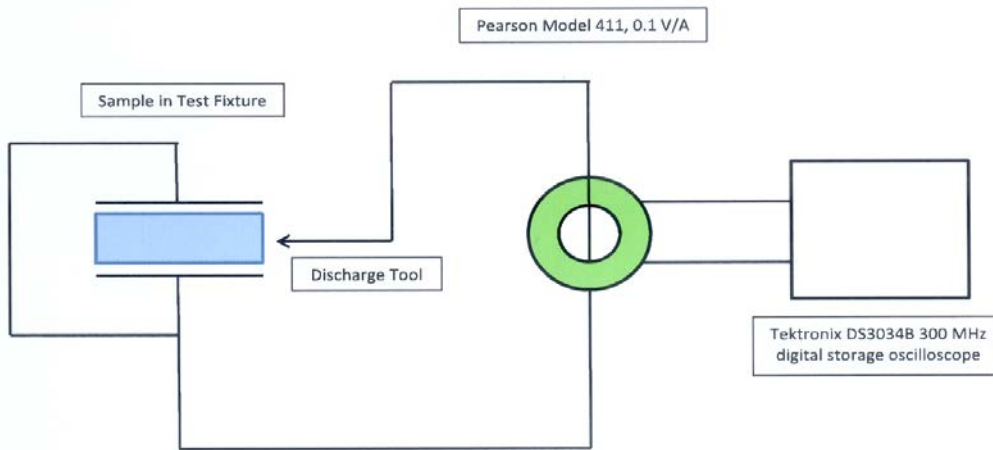

Figure 2.6: Schematic diagram of Hickman's experiment.

Briefly, Captured Lightning® sculptures are made as follows: Electrons are injected into polymethyl methacrylate (PMMA). This material, commonly known as 'acrylic', is sold under various trade names such as Lucite, Plexiglas, or Perspex. PMMA has a unique combination of high optical clarity and superior electrical and mechanical properties. A number of other clear polymers, such as polycarbonate (PC), polystyrene (PS), polyethylene terephthalate (PET), and polyvinyl chloride (PVC) can also be used to make Lichtenberg figures with varying degrees of success.

Electrons are injected using a 150 kW particle accelerator called a Dynamitron. The heart of this device is the accelerator tube - a huge four-storey-high evacuated "vacuum tube" that operates at voltages between one and five million volts. At the top of the tube, electrons are emitted by a small, white-hot tungsten filament. The filament is also connected to the negative output terminal of a multimillion-volt power supply, while the bottom of the tube is connected to ground and the positive terminal of the high voltage power supply. This configuration creates a very strong electrical field that accelerates electrons emitted from the filament to a very high velocity as they 'fall' through the large potential difference towards ground. The bottom of the vacuum tube has a very thin titanium window that separates the high vacuum on the inside from air, at atmospheric pressure, on the outside.

The high velocity electrons pass right through the titanium window. The electrons then emerge from the outside surface of the window, and then travel through air before crashing into the acrylic specimens on the movable carts below. Because acrylic is an excellent insulator, the excess charges cannot escape, and the carts transport the fully-charged specimens out of the accelerator. The specimens are forced to discharge by poking them with heavily insulated, pointed metal tools. The small divot creates a tiny region where the electrical stress overcomes the dielectric strength of the acrylic. The increased electrical stress breaks the chemical bonds that hold the acrylic molecules together, stripping away

free electrons in a process called ionisation. The newly freed electrons are then accelerated by the extreme electric field, and these collide with, and ionise, more acrylic molecules. Portions of the acrylic abruptly become electrically conductive in a runaway process called “avalanche breakdown”.

Within billionths of a second, a network of branching, conductive channels form within the acrylic as, with a bright flash and a loud bang, the material suddenly undergoes dielectric breakdown. The previously trapped electrical charges rush out in a torrent as thousands of smaller branches dump their share of charge into larger channels, eventually merging into a single, brilliant discharge path that exits the acrylic.

As mentioned, Hickman’s sculptures are typically made using PMMA, PC, PS, PET or PVC. Glass has been tried on several occasions, although it tends to shatter, either at the time of discharge, or –unpredictably - weeks or months afterward.

There is therefore significant evidence that electrical breakdown processes within solid dielectrics are similar to chemical or electronic detonation. It would therefore appear that the internal pressure from the discharge shock wave and vaporization of the channel wall material is not sufficient to overcome the strength of the acrylic for Hickman’s Lichtenberg (arborescent) figures. This would explain why lightning explosive barotrauma is not evident in these experimental settings.

2.1.14 The work of Ohashi and Kitigawa

Ohashi and Kitigawa (Ohashi, 2001, 1986; Kitigawa, 1985) through process of elimination came to the conclusion that blast injury results from the explosive vaporization of superheated water along the path of the surface flashover. To investigate their hypothesis, an experiment model of a lightning strike was created in the adult Wistar rat. Saline-soaked blotting paper was used to simulate wet clothing or skin, and an artificial lightning impulse was injected. The resultant lesions were consistent with their hypothesis that the blast was reinforced by the concussive effect of water vaporization. Solid organ rupture, pulmonary and intracranial haemorrhage, and skull fracture were created in a model of a direct lightning strike in rats. These injuries were thought to be due to the concussive effect of rapidly expanding steam produced by superheating water on the body surface by a surface flashover (streamer). *The flash moisture vaporization theory* has been proposed to explain some of the common findings in patients who have sustained lightning injuries.

2.1.15 Surveillance of the older medical literature

Lightning concussive injury has been discussed in the older medical literature (Critchley, 1932, 1934; Jellinek, 1932; Panse, 1925, 1930). There seems to be very little attention as to *why* the concussion developed. The literature holds many examples of errors due to overlooking the effects of a fall. The papers discuss the neurological effects after a fall, which may have been due to unsuspected fracture of

the skull or dislocation of a vertebra. The reasons behind the fall seem not to have been addressed by these papers. For example, were the falls due to lightning concussive injury or opisthotonic muscle contractions?

2.1.16 Surveillance of the newer medical literature

Blunt force trauma effects have been addressed in the newer medical literature, specifically concussive injury and musculoskeletal injury from falls (Auerbach, 2012). Once again, little attention has been placed on *why* these victims fall in the first place: Do they first lose consciousness and then fall? Or do they first fall and then lose consciousness? Does lightning induce startle reactions, reflex movements or opisthotonic muscle contractions? (Fish, 2008: 429).

“Lightning related muscle contractions are often so severe that they lead to bone fractures. In cases where lightning has struck the head, deep seated thermal necrosis, skull fractures, and epidural, subdural, subarachnoid, and/or intracerebral haemorrhages have been described. The lightning related blast can lead to ruptured internal organs – for example, the bladder – or to vascular ruptures – for example, aortic rupture” (Zack 2007: 5).

Please note that a review of the forensic pathology literature could not corroborate any of the aforementioned clinical findings. There exist no forensic pathology peer-reviewed articles on lightning and skull fractures or lightning and aortic rupture or lightning and bladder rupture, for example to date.

2.2 Summary:

It would appear from the available chronological literature review that the existence of a blast wave surrounding lightning's luminous channel has been known to exist since the time of Pliny the Elder. The existence of a blast wave around a spark has also been known to exist for a time.

The literature on the injuring effects of lightning's pressure blast wave was difficult to locate due to the *multiple different terms* used to describe it: 'Arc blast', 'shattering effects of lightning', 'pressures developed by arcs', 'thunder generation of shock waves', are but a few examples of the many divergent and disparate terminologies used to describe this invisible blast phenomenon (Lee, 1982; Lee, 1986; Lee, 1987; Rakov & Uman, 2005).

We know that a pressure shock wave exists around lightning's luminous channel. We can hear it. The audible distance of thunder is about 14km (Kitigawa, 2003) to 25km (Uman, 1970). This means that a tremendous amount of energy is involved in the generation of thunder. However before thunder exists, there is a pressure blast wave and it is this blast wave which decays, within meters, and transforms into thunder.

Lightning causes an instantaneous super-heating and expansion of the air close to the victim's body, followed almost immediately by an implosion as

the air rapidly cools. Halldorsson et al. believed that this explosion/implosion phenomenon surrounding lightning's luminous channel may cause trauma which may mimic the patterns of blast injuries seen in bomb blast victims (Halldorsson, 2004).

The five traditional mechanisms of lightning injury are relatively well-entrenched within the scientific literature, yet this literature does not seem to adequately address explosive barotrauma as a mechanism of injury. An umbrella term, namely the 'sixth mechanism of lightning injury' is therefore proposed to address aforementioned phenomenon in this thesis. A neologism does not constitute a contribution to knowledge in a field, yet the term 'sixth mechanism' will be used in the remainder of thesis to describe the pathology of trauma not covered by the traditional five lightning injury mechanisms.

In order to appreciate the idea of lightning being associated with blast-type effects, one needs to appreciate the requirements to produce a blast shock wave. One of the primary requirements is a fast-moving high-magnitude pressure wave (shock wave) generated by the sudden release of a large amount of energy. Lightning has the ability to deliver very high current magnitudes (100s of kilo Amps) with rise times in the microsecond range. This phenomenon results in almost instantaneous release of large amounts of energy due to thermal heating of the air immediately surrounding lightning's discharge path.

What is more, none of the previous papers have addressed the nature of this 'pressure-shock wave' from a pathology-of-trauma point of view:

- If this blast wave does indeed exist, what does it look like?
- And, within what range is one at risk and what is the risk?

These questions are important from a forensic practitioner's viewpoint in that they will help to determine the risks posed to victims and in the forensic reconstruction of lightning events.

The remainder of this thesis is dedicated to addressing these objectives.

CHAPTER THREE – ADDITIONAL EVIDENCE

This chapter will focus on additional evidence of the phenomenon as observed in forensic pathology practice.

3.1 Additional evidence of a sixth mechanism

Case study 1:

In 2010 an unusual keraunopathological phenomenon was discovered at an autopsy examination. What made this phenomenon so unusual was that it possibly suggested a sixth mechanism of injury with regards to lightning strike (Blumenthal, 2012b).

3.1.1 Background history

A forty-eight-year-old female, her thirty-four-year-old son and her ten-year-old daughter were walking on a relatively urbanised road, outside Pretoria in the suburb of Eersterus, on 24 October 2010. They were walking on the pavement under a Jacaranda tree (*Jacaranda mimosifolia*).

There was an electrical thunderstorm and they were caught in heavy rain. All three of the individuals were described as “very wet” at the time. At 17h45 lightning hit the Jacaranda tree (‘side flash’ was the diagnosed lightning injury mechanism) and killed the mother. Her son was knocked from his feet. Her daughter was also knocked down by the strike. Both the son and the daughter survived the lightning strike. The son sustained a 2,0 cm x 1,0 cm abrasion on his left kneecap. The daughter was affected psychologically and stayed home from school for one week.

This case study will focus on the 48 year-old female, who died due to the third mechanism of lightning strike. It will focus on another interesting and unusual injury phenomenon that she sustained and that thus far has never been described in the literature.

3.1.2 Scene investigation

Scene examination showed the Jacaranda tree to have been struck by lightning. There were two areas within the branches where the bark had been stripped off by the lightning. Small wood chips from the Jacaranda tree could be identified up to a maximum distance of 5 meters away from the tree.

Interestingly, there were two craters in the concrete on the pavement on the right side of the body of the victim. These two craters measured 11,0 cm x 9,0 cm x 4,0 cm in size and 4,0 cm x 4,0 cm x 1,0 cm in size, respectively. It was confirmed from witness reports that these two

craters, which were spaced 7,0 cm apart, were not present on the pavement prior to the electrical thunderstorm on that day.

3.1.3 Post mortem examination

Post mortem examination showed an adult female with torn and tattered clothing overlying the abdominal- and right inguinal regions. The clothing showed blackened charring of the edges. Superficial charring of the skin was noted overlying the midline of the sternum, the anterior aspect of the abdomen and the right inguinal region. Features were in keeping with the available history of lightning strike (or "side flash").

The findings on her body were in keeping with the available literature on lightning. However, an interesting phenomenon was discovered on the victim's lower limbs, which is the topic of this case report. Signs of secondary missile injury (shrapnel injury) were detected on the right side of her lower legs. It almost looked like an explosive device had detonated on the right side of her body, as illustrated in figure 3.1.

Examination of the shrapnel wounds on the skin of the deceased showed small pieces of concrete embedded within the wounds. Please refer figure 3.2.

Examination of the concrete pavement showed the area where the lightning had hit the ground. Blast / explosion effects on the concrete pavement were identified on the right side of the victim. Please refer figure 3.3.

Features were in keeping with secondary missile injury (shrapnel injury) from lightning strike. This is the first time such a finding has been reported in the literature.

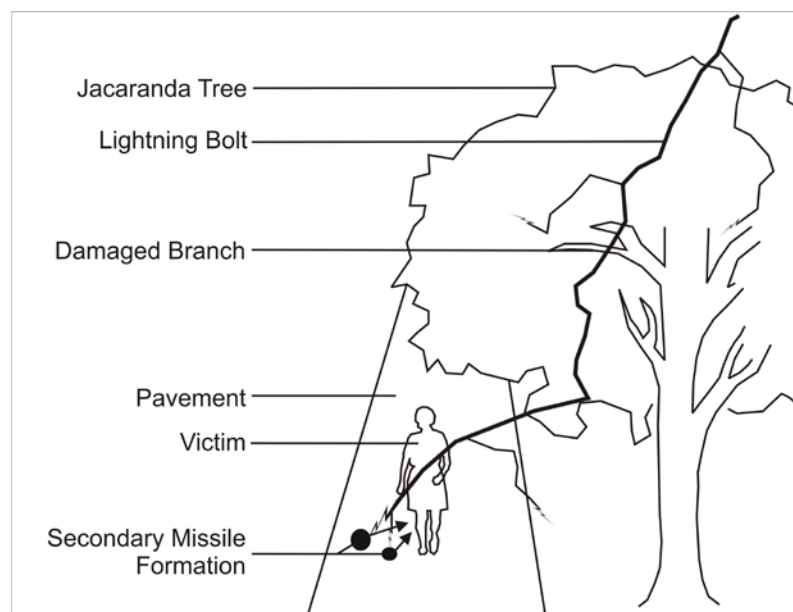

Figure 3.1: Diagrammatic representation of the lightning strike event as described. Note the lightning 'splashing' and/or 'flashing' off the tree (third mechanism), striking the victim and then striking the concrete pavement. The concrete pavement 'exploded' (sixth mechanism).



Figure 3.2: Shrapnel wounds noted on the right side of the victims lower legs. Examination showed multiple small pieces of concrete shrapnel lodged within the victim's wounds. Note the 'shadow' area on the medial aspect of the left upper thigh region, where the right leg served as protection from the shrapnel. Such a finding can help recreate the exact position of the legs of the deceased at the time of strike.



Figure 3.3: Blast / explosion effects from the lightning noted on the concrete pavement on the right side of the victim.

3.1.4 Discussion

"Shrapnel", in the strict sense, is material deliberately included in a landmine or shell and intended to be scattered by the explosion. More loosely, the term is used to refer to any fragments or debris propelled by an explosion. The word is derived from Henry Shrapnel, an English artillery officer who, in 1784, began developing in his own time and at his own expense an antipersonnel weapon composed of a hollow spherical projectile filled with shot and explosive charge (Rich, 1967). It was designed to detonate in mid-air, scattering the shot and shell fragments. In the context of this case study, the term "shrapnel" and/or "secondary missile injury" is used to describe the specific wound phenomenon observed on the victim.

As mentioned earlier, keraunopathology is the study of the pathology of trauma of lightning on the human and/or animal body. Careful attention to detail in lightning strike cases can further advance the field of keraunopathology.

This case report demonstrates the phenomenon of secondary missile formation (shrapnel injury) with regard to a lightning strike incident and represents one of the first of its kind reported in the literature.

In other words, features were consistent with Elsayed and Atkin's (2008) classification of secondary blast-related injuries that result from flying debris (eg, glass, concrete, wood) striking the victim, resulting in penetration or less commonly blunt trauma.

3.2 Additional evidence of a sixth mechanism

Case study 2:

In 2011 a further unusual keraunopathological phenomenon was discovered at an autopsy examination. What made this phenomenon so unusual was that it also suggested a possible sixth mechanism of injury with regards to lightning strike.

Two women and a baby were struck by lightning in December 2011. The 23-year-old female and her baby survived with no complications. The paramedics arrived and declared the 41-year-old female dead. What follows are the, as-yet unpublished, post mortem findings of the 41-year-old female fruit shop vendor.

The unusual keraunopathological finding noted at autopsy was relatively advanced traumatic emphysema (pneumomediastinum) on the posterior aspect of the sternum. The possible pathophysiological origin of this phenomenon suggests lightning explosive barotrauma.

3.2.1 Background history:

In December 2011, a 23-year-old woman, together with her baby were purchasing vegetables at a taxi rank in rural South Africa. The fruit shop vendor was a 41-year-old female.

The fruit shop had been informally constructed from wooden poles. Lightning struck and all three females were witnessed to have fallen to the ground. The vegetable-seller allegedly immediately fell down dead onto a sack of potatoes. The 23-year-old female and the baby were also knocked down to the ground, although no further injuries were reported in either the mother or the child.

The 41-year-old vegetable vendor was declared dead by the paramedics.

3.2.2 Scene investigation:

Unfortunately, the original scene was disturbed by the many local people present. When the South African Police Services arrived, they found the deceased lying face-down between two of the informal fruit-shops.

The deceased, a 41-year-old female was found lying face-down over a sack of potatoes. There was no mention of whether or not she was wet or dry at the time of the lightning strike. There was no history of anyone having performed cardiopulmonary resuscitation on the victim.

3.2.3 Post mortem examination:

A medico-legal post mortem examination was performed as per the South African Inquests Act (Act 58 of 1959).

Chief post mortem findings showed no obvious external injuries to the body; although tears and burn marks to the clothing were present, which were suggestive of lightning strike.

No other substantial or obvious injuries or cause of death was demonstrated at autopsy.

Interestingly, there was relatively widespread distribution of fine air bubbles within the mediastinal soft tissues, in keeping with traumatic emphysema (pneumomediastinum), extending around the oesophagus and pericardial sac. No evidence of haemorrhage could be noted in the region.

The body had been refrigerated and rigor mortis was still present. There were no signs of post mortem autolysis or decomposition present. Specifically, there were no signs of post mortem gas formation noted.

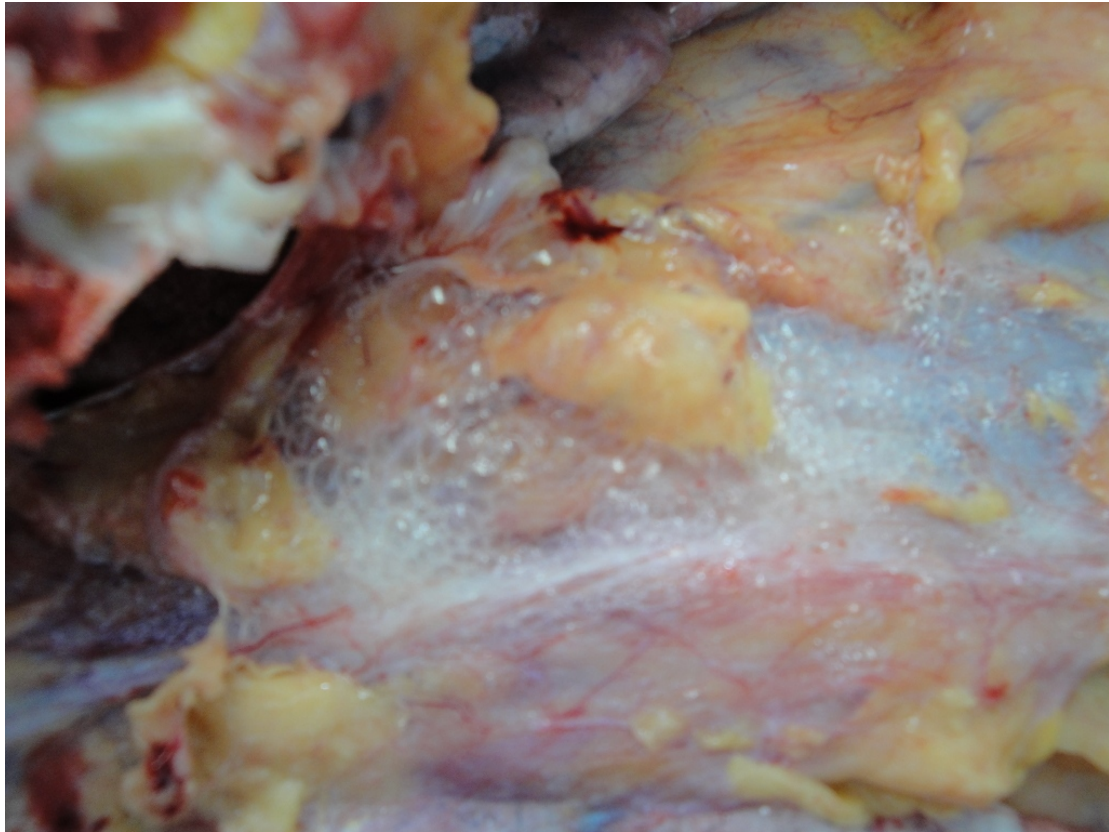

Figure 3.4: Pneumomediastinum noted on the posterior aspect of the sternum. Note the multiple small 'bubbles' in the soft tissue. (Photograph courtesy of Prof G Saayman from the Department of Forensic Medicine, University of Pretoria).

Histology of the lungs showed areas of disruption of the normal architecture of the pulmonary parenchyma, with irregularly over-distended peripheral air spaces and what appeared to be attenuated and ruptured alveolar walls.

Toxicology showed no drugs and the blood alcohol concentration was 0.00 grams per 100 millilitres.

3.2.4 Discussion:

Pneumomediastinum was first described in the medical literature in 2004 (Halldorsen, 2004).

The precise pathophysiology of this phenomenon remains somewhat obscure; although suggests toward a lightning-related barotrauma-type mechanism.

CHAPTER FOUR – THE EXPERIMENTS

This chapter is central to this thesis and introduces two novel experiments specifically designed to investigate the existence of the sixth mechanism.

4.1 The sixth mechanism: Lightning explosive barotrauma

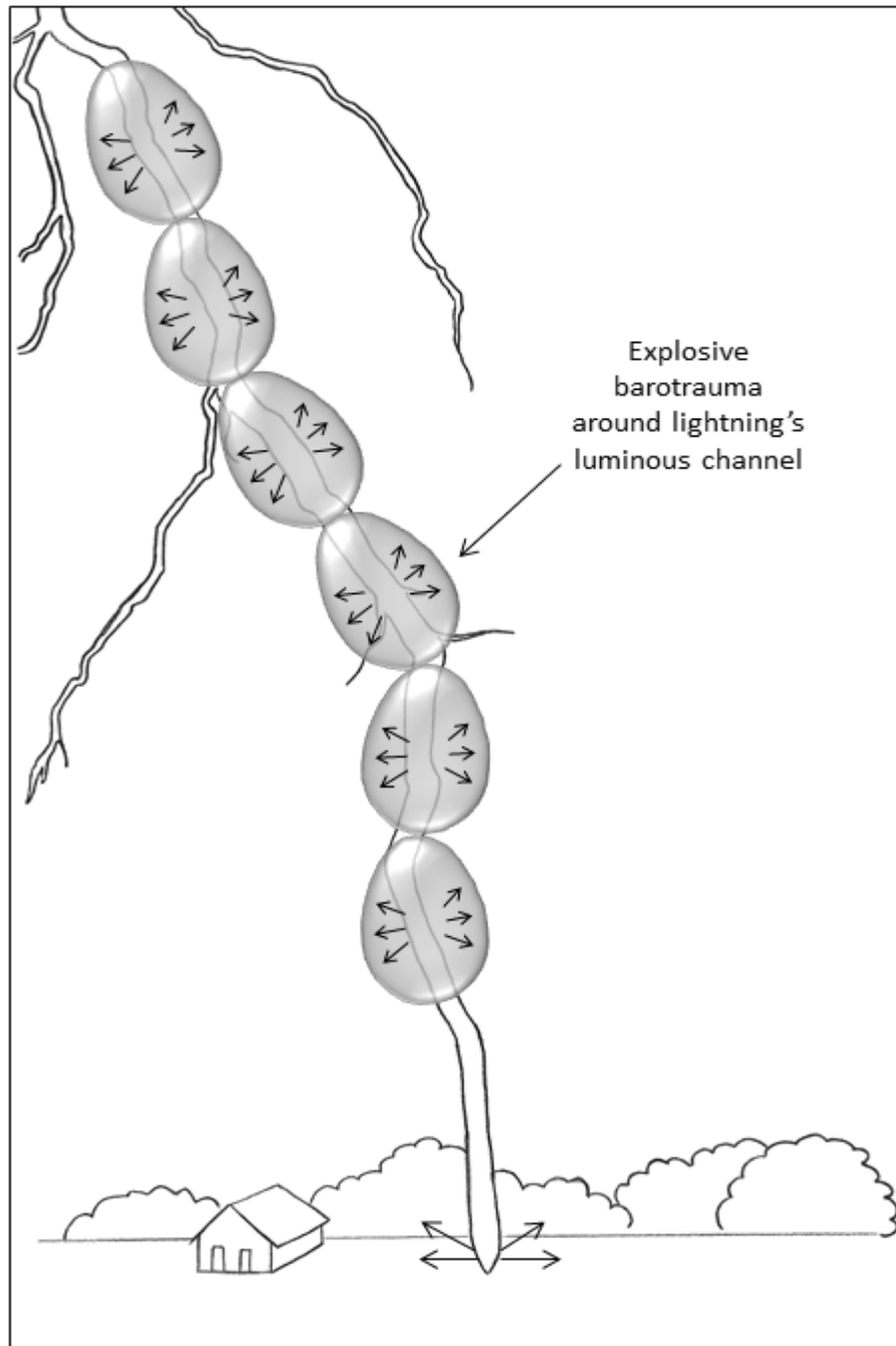

Figure 4.1: Proposed appearance of the sixth mechanism of lightning injury. Please keep in mind that the lightning channel is three-dimensional.

Aforementioned review of the literature on lightning physics together with the associated case reports demonstrating shrapnel injury and pneumomediastinum led to the development of two novel experiments, which were conducted at the University of the Witwatersrand's High Voltage Laboratory.

What follows is a description of the two papers together with the findings.

4.1 THE 2012 EXPERIMENT:

This research led to an original paper which was published in the *American Journal of Forensic Medicine and Pathology* (Blumenthal, 2012a).

4.1.1 Materials and Methods

A novel experiment was conducted to test for the presence or absence of a blast wave surrounding lightning's luminous channel. The testing took place at the University of the Witwatersrand's School of Electrical and Information Engineering High Voltage Laboratory and utilised an 8/20 microsecond current impulse generator (Tektronix TDS 3014b oscilloscope) and an isolation transformer. The isolation transformer was used to protect the oscilloscope. Please note that this waveform does not represent that of natural lightning which has a longer rise and fall time.

The 8/20 microsecond waveform is commonly used for electrical testing and was decided upon for the purposes of our experiment. These waveforms are indicative of induced currents due to a nearby direct strike. The energy is less (due to shorter duration) and therefore excellent for a proof of concept approach. Incidentally, the impulse wave shape in McKelvie and Page's (1980) experiment, used a 1/50 microsecond impulse wave shape.

Some further considerations with respect to the waveform used in our experiment: The current waveform of a direct lightning strike is modelled as a 10/350 waveform. This means that the rise time (time to get from 10% of peak to 90% of peak) is 10 microseconds. The fall time (time to reach 50% of the peak value) is 350 microseconds. This waveform, due to its long duration, delivers a significant amount of energy as one would expect from a direct lightning strike. In a laboratory environment, this energy is difficult to manage.

What made this experiment unique was the utilisation of *ballistic gel* to determine whether or not a blast wave existed around the lightning channel or not.

The thinking was that discharging lightning through different viscosity jellies would leave a near-perfect imprint shape of the pressure blast wave immediately around lightning's luminous channel and capture the shape of the pressure shock wave. Discharging lightning through gelatine represented an original idea which had never been conceived before in the literature.

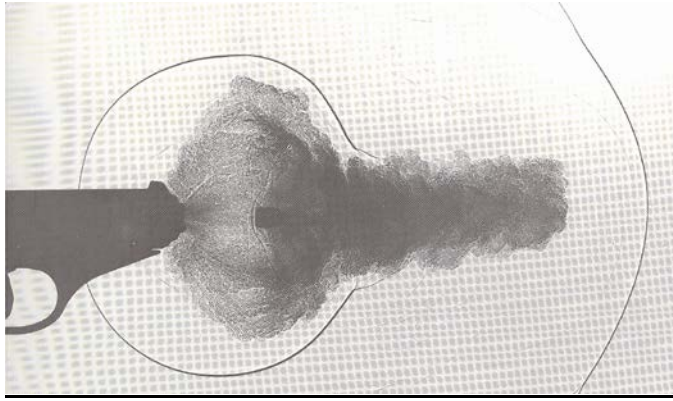

Figure 4.2: Gas flows at a muzzle having just fired a shot. Note the shock wave at the tail of the bullet, showing the high gas velocity (Sellier & Kneubuehl, 1994).



Figure 4.3: Axial view in the direction of the gunshot. Gelatine block with a gunshot (Sellier & Kneubuehl, 1994).

There is sufficient data regarding tissue simulants such as gelatine with regard to projectile testing. In their book entitled "Wound Ballistics and the Scientific Background" (Sellier and Kneubuehl, 1994) the authors give a good exposition of shooting tests through gelatine blocks, the premise being that when a projectile is shot through ballistic gel there is a 'crunch-punch-tear' effect, which causes a permanent cavity, and a 'stretch-splash' effect, which causes a temporary cavity.

"When a high-velocity bullet enters the body and ploughs through tissue, it is obvious that material in its path will be thoroughly disintegrated. A permanent cavity, filled with blood and pulpated cells, is gouged out. In addition, immediately behind the moving missile, a large temporary cavity appears, many times the cross-sectional area of the missile itself. This temporary cavity quickly subsides, but tissue at its periphery has been greatly stretched and cells may be injured. The temporary cavity is the most important item in wound ballistics of high speed projectiles. Temporary means that the cavity only exists for a short period of time after penetration of the projectile. The permanent cavity is the permanent shooting channel or tube which remains afterwards. The pressure of the projectile shock wave may be as low as 4 atmospheres and as high as 60 atmospheres" (Sellier & Kneubuehl 1994: 131,147,289,295).

4.1.2 Tissue Simulants

Bioethical reasons have necessitated medical science to create substances analogous to human tissues, in order to test the effects of kinetic energy on the human body.

4.1.2.1 Normal Gelatine:

Normal gelatine was used initially to test the effects of the current impulse generator. Gelatine is the protein produced from collagen when it is submitted to treatment to make it water-soluble. In general, gelatine is obtained from skin, bones and tendons from animals. The jelly strength of gelatine is measured by the so-called "Bloom number".

"The Bloom number is a general measurement of the consistency of jellies. The unit is defined as the mass of a cylindrical stamp (diameter 12.7mm), necessary to penetrate 4mm into the jelly. For this, a jelly concentration of 6 and 2/3% and a temperature of 10 degrees Centigrade with a tolerance of 0.1 degree Centigrade are required" (Sellier and Kneubuehl 1994:190).

Gelatine is available in consistencies of between 50 and 300 Bloom. For shooting tests type A, jellies with a Bloom number between 250 and 300 are usually used.

4.1.2.2 Corbin's SIM-TEST™ ballistic test media:

SIM-TEST™ Ballistic Test Media was selected as the test medium in our experiment. Corbin's SIM-TEST™ ballistic test media is a stable, animal-protein based "simulated tissue" for consistent bullet performance tests. The material is marketed by the company as a close match to muscle tissue in density and consistency. The density is 1.3 gm/cc. Density could be adjusted by controlling water content.

Formaldehyde-fixed human muscle density is approximately 1.0597 gm/cc. A density value (mean±SE) of 1.112±0.006g/cc in 4% formaldehyde-fixed muscle and 1.055±0.006g/cc in 37% formaldehyde-fixed muscle has been cited in the literature (Ward, 2005).

SIM-TEST™ had advantages over wet newspaper, water, clay, conventional ballistic gelatine and other test materials commonly used as a bullet expansion medium:

- It was stable at room temperature;
- It was ready to use without mixing;
- No refrigeration was required;
- It was re-usable and re-castable; and
- It was non-toxic, water soluble with easy clean up and had close simulation of actual tissue.

The experiment utilized normal cooking Gelatine at the outset and SIM-TEST™ Ballistic Test Media, a thin-piece of conductive wire and an 8/20 microsecond Current Impulse Generator and an isolation transformer.

One of the questions raised early in the experiment was why we put the wire *inside* the gel instead of simply shooting the electricity at it to see what happened. We do not have wires going through our bodies or muscles and it seemed the secondary effect might be clouded from wire 'contamination' (contaminants precipitated in the wire). The goal of this experiment was to 'capture' the three-dimensional shape of the pressure-blast-wave around lightning's luminous channel. This therefore was the reason the wire perforated through-and-through the ballistic gels.

Another question raised was why we used different gauges of wires inserted through blocks of gel to investigate our hypothesis. Lightning injury experiments have a long history utilizing wire: Supplementary experiments were performed by Ohashi and his colleagues in which they fixed a copper wire of 10cm length on a rat's back from scalp to loin. When the electrical impulse was applied, the surface flashover bridged the two paths, a short one between the scalp electrode and the scalp end of the copper wire a long one between the loin end of the copper wire and the posterior leg electrode. In these experiments all the rats survived. The copper wire facilitated the flashover, shortening the duration of the high voltage and thus diminishing the energy dissipation within the body. They named this the 'Zipper Effect', because the long metal zipper on the back of a full-size dummy clearly exhibited the same effect in discharge experiments simulating the lightning strike on the human body. In their experiments, a 40cm long metal zipper was placed on the back of the dummy appreciably increasing the flashover current and diminished the current within the body. Thus it was deduced that such a long metal piece along the body could provide survival conditions in cases of lightning accidents (Ohashi, 1986). Our thinking was that, all things being equal (for example, the gelatine blocks and the wire) then we could test solely for the effects of the lightning, keeping in mind that once attachment has been achieved, lightning becomes a current and not a voltage phenomenon.

Forensic pathologists have a long tradition of using ballistic gel in projectile testing. Ballistic gels have successfully been used to determine the wounding power of a projectile. The formation of permanent and temporary cavities in gels has helped shape and advance the field of bullet design. The transfer of energy from a projectile to tissue is determined principally by the following factors:

"The shape of the foremost section of the projectile. The larger the foremost surface, the greater the braking action that is exerted on the projectile by the tissue and therefore the greater the quantity of energy lost by the projectile. A cylindrical projectile with a flat front for example, imparts to its surroundings approximately three times as much energy per centimetre of tissue penetrated as a pointed bullet of the same calibre, velocity and mass. The foremost surface of a projectile becomes enlarged when striking and piercing tissue due to its yaw and nutation" (Schwär 1988: 232).

"The sectional density (Q) of the particular projectile. This can be expressed as $Q = G/F$, being the quotient of the mass (G) of the projectile and the size of the foremost surface (F). The bigger the Q, the smaller the braking effect of the tissues and therefore the lesser the quantity of energy lost to the tissues" (Schwär 1988:233).

"The density and elasticity of the medium penetrated. The denser the tissue, the greater the braking effect and, therefore, the more energy transferred per centimetre tissue penetrated" (Schwär 1988:233).

"When a projectile penetrates a block of gelatine the pressure causes the bullet channel to rapidly expand and to create a temporary cavity which collapses when the pressure subsides. The expansion and probably also subsequent pulsations break the structure of gelatine in it creating a channel. It is generally accepted that the fissures thus formed reflect the distribution of kinetic energy dissipated by the projectile into the stimulant. There are a number of methods used for calculating this kinetic energy" (Jussila 2005:53).

Ballistic gels have the potential to contribute to the advancement of knowledge in this subject as described above.

The experimental set-up in the 2012 experiment was considered new and original. The pressure shock wave immediately surrounding lightning's luminous channel can now be observed and described.

The aim of the experiment was to determine the shape and nature of the 'pressure shock-wave' surrounding the long electrical spark. The wire made sure that the long electrical spark did not flash over the gelatine blocks. What is important to realise is that, all things being equal, (the wire and the gelatine blocks for example – with all their associated contaminants), the only things being tested for in this experiment were current, voltage and size and shape of the cavity.

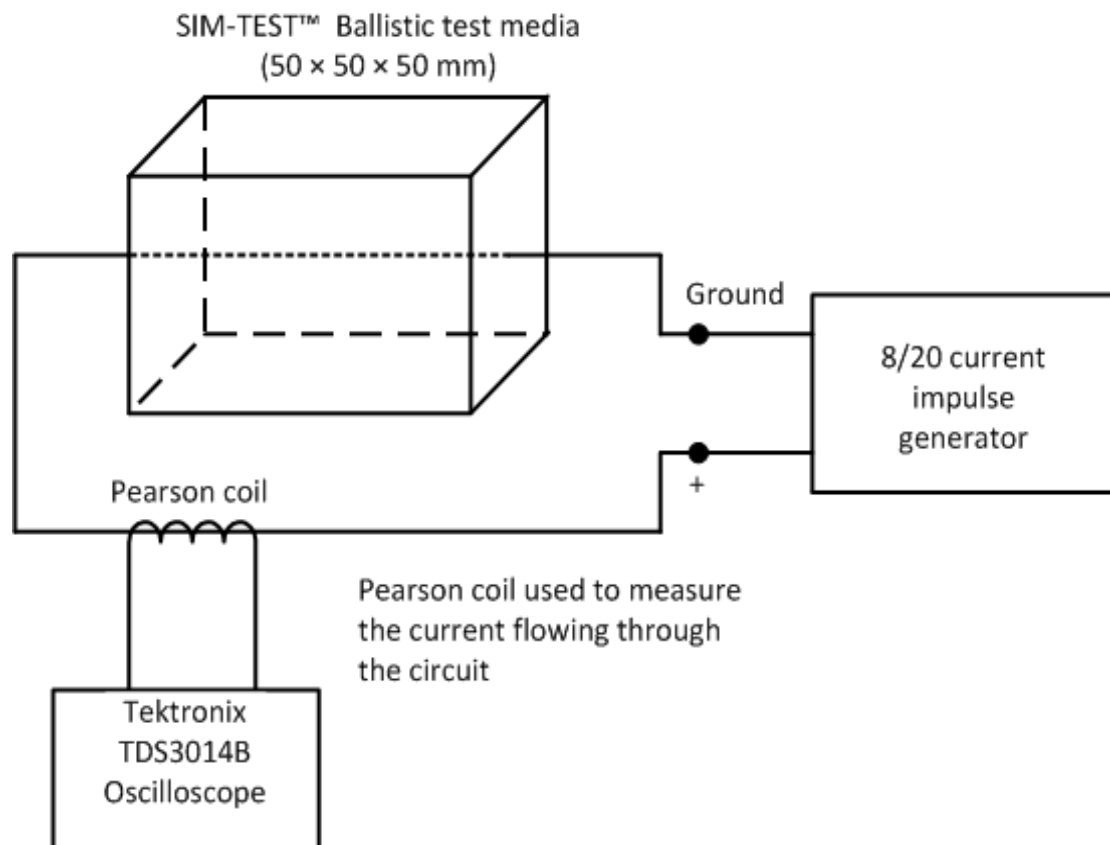

Figure 4.4: The 2012 'sixth mechanism gel experiment': Physical layout of current impulse generator and test object (the gelatine block).

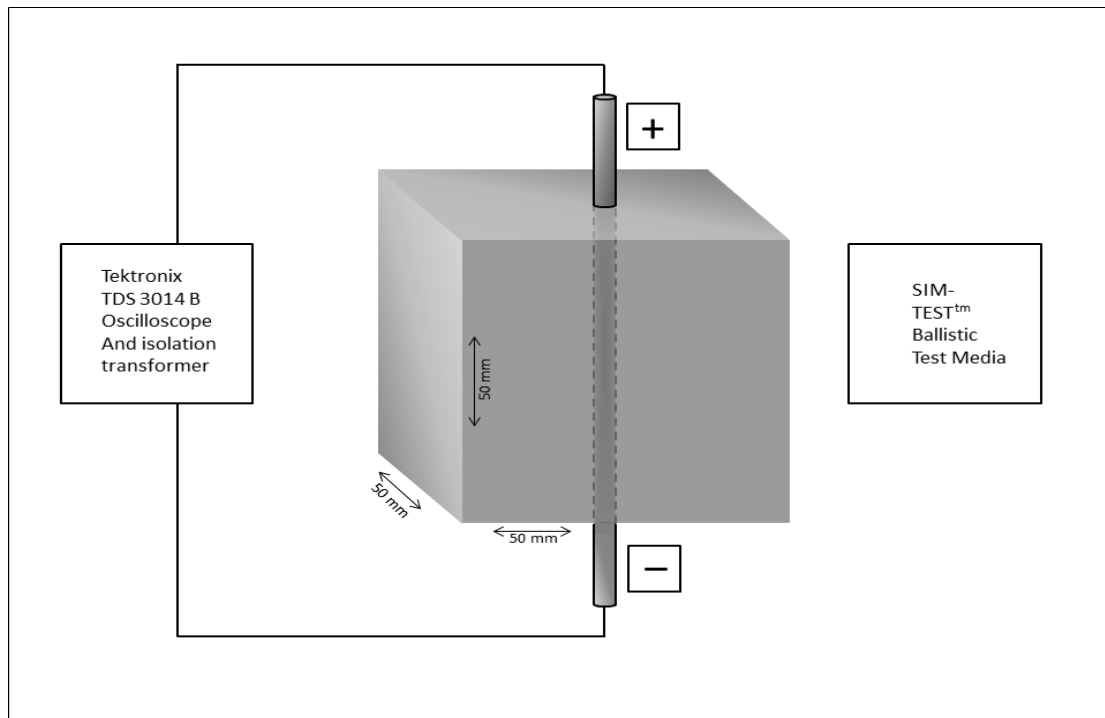

Figure 4.5: Three dimensional view of the 2012 'sixth mechanism gel experiment'.

The experiment was repeated using incremental discharges beginning at 1 kV to 20 kV.

(The experiments were later repeated, independently, using wires of different resistances. Please refer to appendices E and F).

As with gunshot wound profiling, the following parameters were sought:

- Temporary cavity formation. The extent of the radial cracks in the gelatine approximates temporary cavity size.
- Permanent cavity formation; and
- The shape of the cavity formed (for example fusiform, cylindrical, etc)

4.1.3 Results

Initially, normal cooking gelatine was used in the experiment to determine the nature and shape of the shock-wave phenomenon. Gelatine moulds were formed at various densities, viscosities and elasticities. The gelatine moulds were made to enable varying threshold velocities, variable threshold energies and various energy densities.

Gelatine proved an excellent medium to study the behaviour of the shock wave in that it was transparent and allowed for optical measurements. High-speed photography was performed in second-phase experimentation and the propagation mode of the blast wave was visibly noted. Since gelatine is made of natural substances, (water and proteins), disposal was also not a problem.

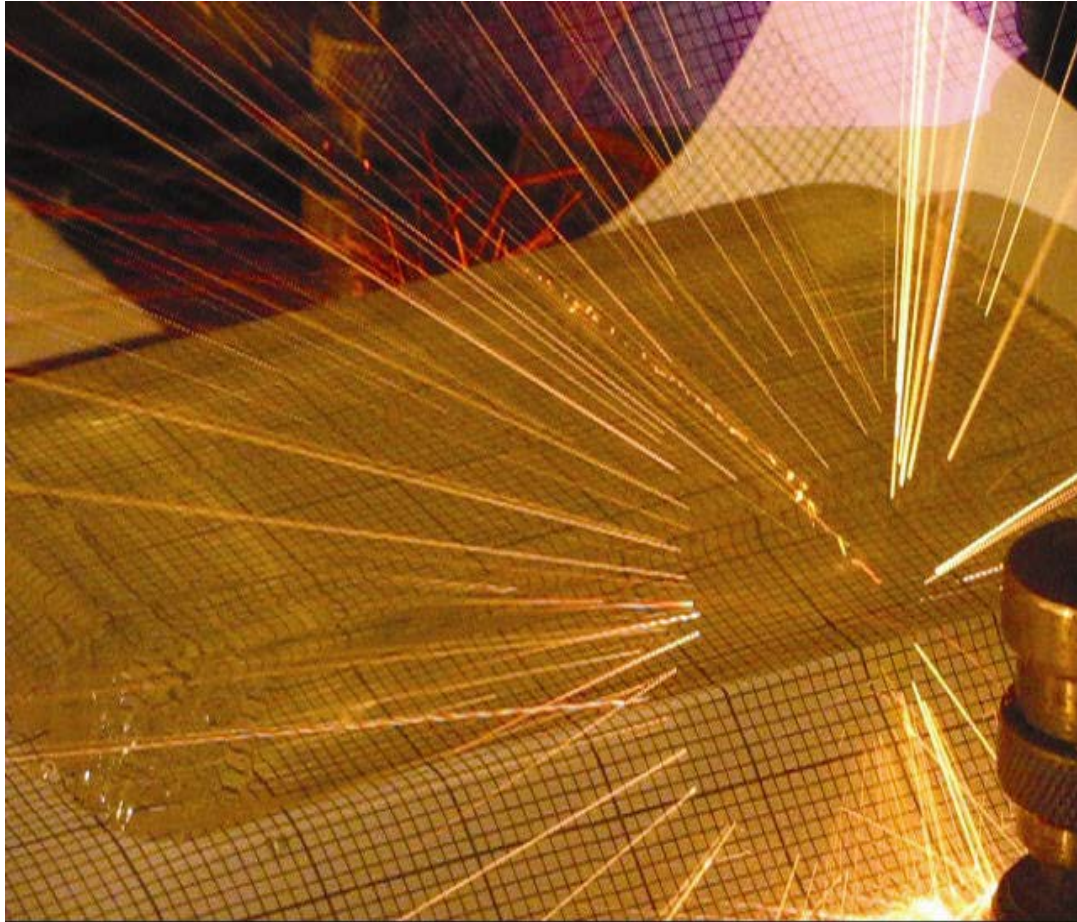

Figure 4.6: High-speed camera footage showing the moment of impulse generation. Note the radial explosion from the wire. The propagation mode of the blast wave through the jelly was visibly noted. Current impulse generated through gel showing radial explosion.

Initial findings were in keeping with the so-called “wound profile” of Fackler (1985). The size of the permanent cavity could easily be seen within the test gelatine. Fackler (1985) called the description of the totality of the projectile effects on gelatine a “wound profile” (Fackler, 1985.)

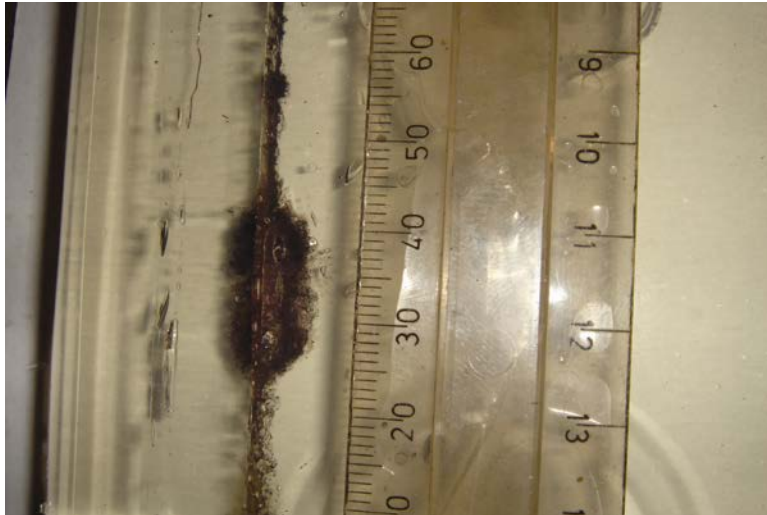

Figure 4.7: Permanent cavity formation. A so-called 'smoke node'. Permanent cavity formation noted in the softer gelatine media. Caterpillar-like explosion defect noted in the gelatine surrounding the disintegrating wire. The 'shape' of the surrounding blast wave is suggested by this imprint defect.

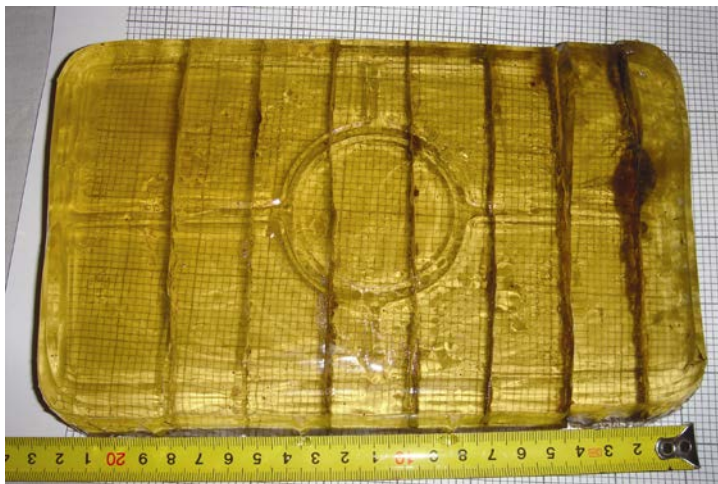

Figure 4.8: Incremental permanent cavity formation. Incremental destruction of surrounding gelatine as demonstrated from left to right at increasing voltages. The voltages were increased incrementally from 1 kV to 6 kV. This represented a serial increase in current from 1,52 kA to 9,0 kA. The gelatine / water ratio represented a 30 mg / 500 ml mix. Notice no visible reaction within the wire at 1 kV (1,52 kA) on the far left. Notice complete wire disintegration with cylindrical 'smoke node' formation at 6,0 kV (9,0 kA) on the far right.

Table 4.9: Initial testing with soft gelatine blocks (50 to 300 Bloom). The following results were obtained. Please note that the findings were based on objective, descriptive appearance of the so-called 'wound profiles'.

Current [kA]	Wire intact	Wire disintegrates	Beading and/or Shrapnel	Node formation	Permanent cavity formation
1.52	x				
2.21	x				
2.70		x		x	
3.22		x	x	x	
3.84		x		x	
4.32		x		x	
4.68		x		x	
5.06		x		x	
5.48		x		x	
6.14		x			x
9.0		x			x

Owing to the fact that the protocol was designed to exclude the testing of projectiles, penetration depth of projectiles and the decomposition of projectiles, the classic 'wound profile' described in the wound ballistic literature could not compare to that of the wound profile caused by a lightning discharge. The only similarity between the two would be the size and/or shape of the temporary and permanent cavities. The permanent cavity was defined by the permanent loss of gelatine surrounding the discharge in the softer gelatines.

The temporary cavity was defined by fissure-fractures in the harder gelatines after testing. Axial views of the fissures-fractures were similar to those seen in projectile testing experiments.

Currents through and voltages across the wire demonstrated six situations:

1. Initially the wire was intact. At higher currents the wire was noted to disintegrate – almost as a fuse would disintegrate.
2. At higher currents beading and/or shrapnel formation was noted surrounding the permanent cavity. Beads of melted wire were trapped within the gelatine.
3. At higher currents and/or voltages (energy) 'smoke nodes' were identified (these were defined as caterpillar-like explosion defects in the gelatine surrounding the disintegrating wire).
4. At higher currents there was directly proportional increasing permanent cavity formation surrounding the discharge.
5. As the currents and voltages increased through the wire, the size of the temporary cavity also increased in a directly proportional manner.

Our team had demonstrated permanent cavity formation within the softer gelatine media (phase-1 testing). Thereafter, experimentation progressed to the Corbin's SIM-TESTtm ballistic test media (phase-2 testing), which is a harder gelatine media. Fifty millimetre cubed blocks (50 mm³) were used and a thin conductive wire was passed through the media from axial

entrance to axial exit. Incremental currents were passed through the conductive wire beginning at 7,30 kA and progressing to 19,8 kA. The diameters of the axial entrance and exit wounds were measured and plotted on a graph against the currents and voltages, as shown in table 4.10 and figure 4.10.

Table 4.10: Initial testing with Corbin’s gel. The following results were obtained. Please note that the findings were based on objective, descriptive appearance of the so-called ‘wound profiles’.

Cal Voltage [kV]	Cal Current [kA]	Entry fissure/fracture diameter [mm]	Exit fissure/fracture diameter [mm]	Average fissure/fracture diameter [mm]
10	7.3	147	157	152
12	8.6	273	190	231.5
14	10.3	320	410	365
16	14.8	360	330	345
18	19.8	540	400	470

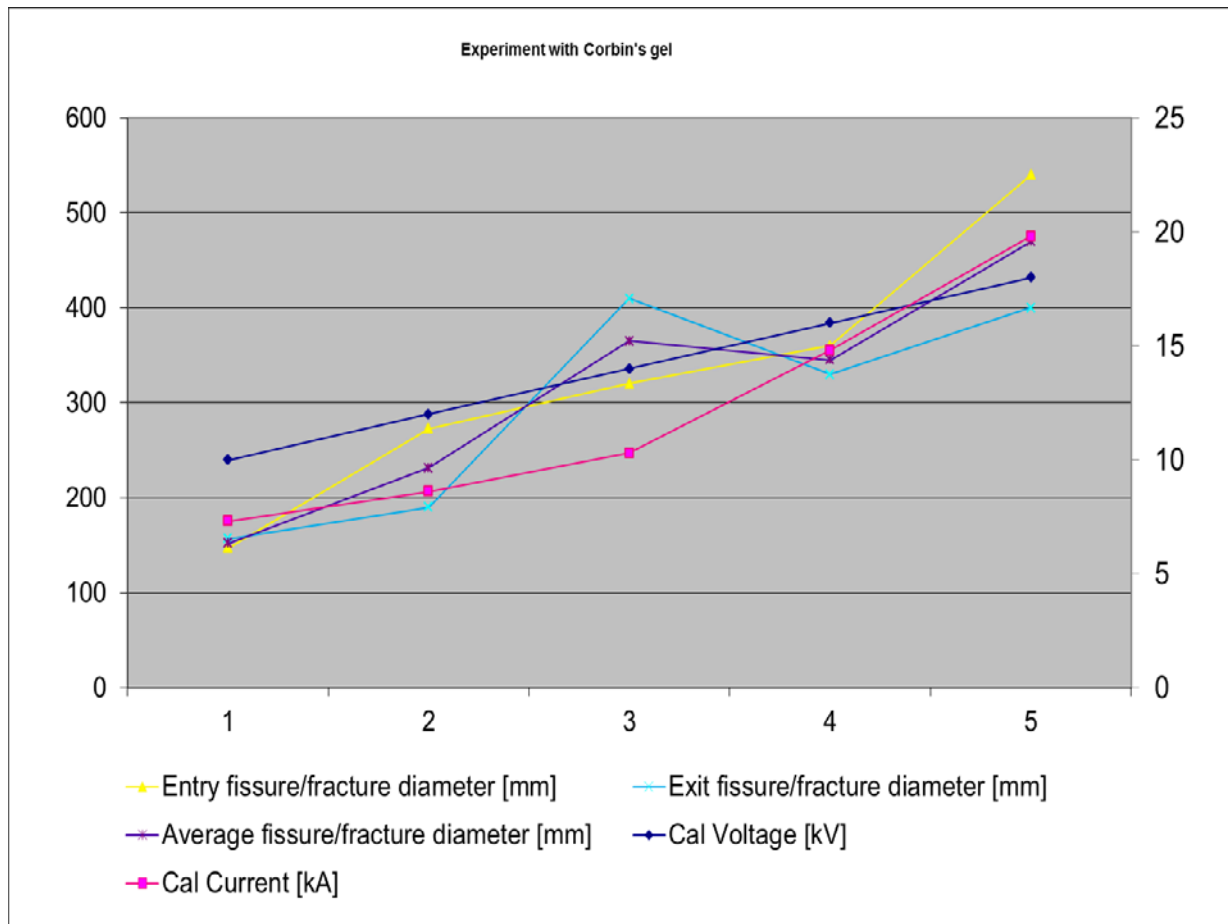

Figure 4.10: Initial testing with Corbin's gel. The x axis plots the current (kA) whereas the y axis plots the fissure/fracture diameters in millimetres. Due to the fact that this represents a 2-D chart with values from a data series which vary widely, and which contain mixed-type of data, a further analysis using a secondary axis in the chart was employed. This method enabled the author to plot one data series (kA) on a secondary vertical axis. A correlation between kA and the entry and exit fissure/fracture diameters exists. It appears from the graph that kA and the fissure/fracture diameters are directly proportional to one another. Please note that the findings were based on objective, descriptive appearance of the so-called 'wound profiles'.

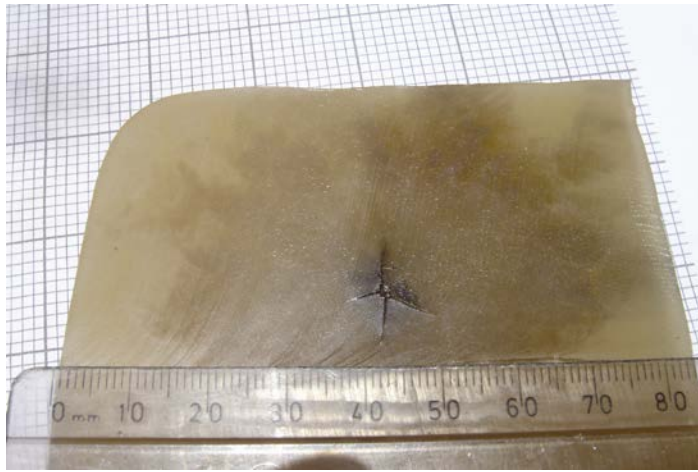

Figure 4.11: Axial view. Corbin's gel. 10 kV. (7,30 kA). Temporary cavity formation demonstrated in the harder gelatine media. Small fissure fracture noted similar to that seen in projectile testing experiments. The current strength measured 7,30 kA.



Figure 4.12: Axial view. Corbin's gel. 18 kV. (19,8 kA). Temporary cavity formation demonstrated in the harder gelatine media. Large fissure fracture noted similar to that seen in projectile testing experiments. The current strength measured 19,80 kA.

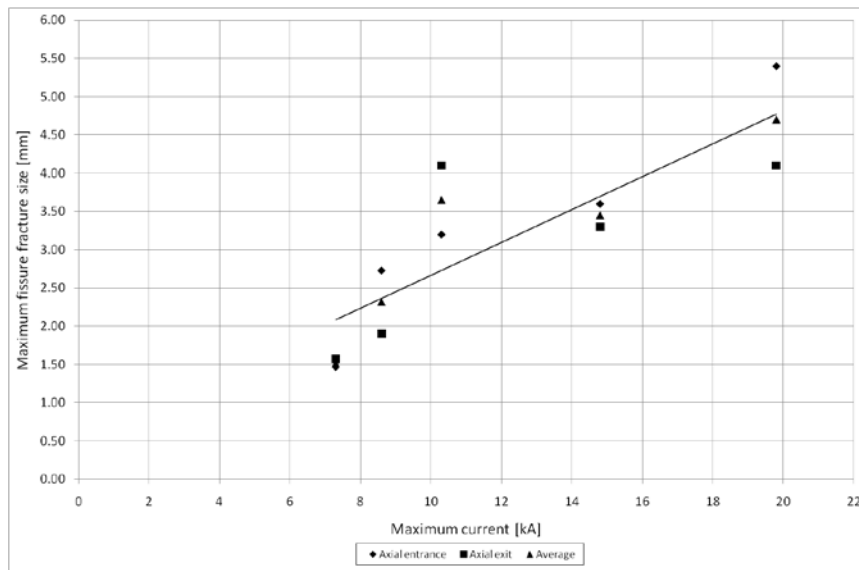

Figure 4.13: Graph demonstrating incremental fissure/fracture cracks in Corbin’s gel. As the current increased through the wire, the size of the temporary cavity also increased in a directly proportional manner

4.1.4 Discussion and Conclusion

Preliminary research with a current impulse generator and ballistic gel confirmed the presence of a destructive cylindrical shock wave immediately surrounding the channel source, which propagated outwards and in a directly proportional manner to the amount of current in the conductive wire.

Permanent cavity formation was demonstrated in the softer gelatine media, whereas temporary cavity formation was demonstrated in the harder gelatine media.

On the basis of the aforementioned findings, the existence of a sixth mechanism of lightning injury, namely lightning explosive barotrauma, was strongly suggested by these preliminary laboratory experiments.

The sixth mechanism of lightning injury may be thought of as a ‘pressure shock effect’ immediately surrounding lightning’s luminous channel. Once attachment has been achieved, lightning becomes a current and not a voltage phenomenon. The pressure shock wave appeared to be directly proportional to the current used in the experiments. A rapidly rising current impulse was therefore capable of producing a shock wave. With all things being equal, the greater the amount of current used in the experiment the greater the surrounding pressure shock wave effect appeared to be (Blumenthal, 2012a).

4.2 THE 2014 EXPERIMENT

This research led to an original paper which was accepted for publication in the *South African Journal of Science* (Blumenthal, 2014b).

The purpose of this experiment was to compare *flash moisture vaporization theory* with the *sixth mechanism theory* and to determine which theory makes for better predictions. A simple proof of concept experiment was performed. This experiment confirmed the existence of a pressure shock wave around a spark in air.

4.2.1 Introduction

Two theories currently exist as to why the clothing ruptures in lightning strike, namely flash moisture vaporization theory (Ohashi, 2001, 1986; Kitigawa, 1985) and sixth mechanism theory.

Both theories seem plausible, yet there are still many unanswered questions which needed to be addressed.

If flash moisture vaporization theory were indeed a reality, why are no forensic pathologists seeing scald burns on lightning strike victims? Surely, superheated water would cause scald burns on the skin of lightning victims? Instead, forensic pathologists are seeing scorch burn wounds on the skin and torn-and-tattered clothing akin to explosive (blast) barotrauma (Saukko, 2004).

4.2.2 Background history

Uman, et al. published a paper on a shock wave from a four-meter spark (Uman, 1970). Plooster studied the cylindrical pressure wave resulting from instantaneous energy release along a line in a quiescent atmosphere by numerical integration of the equations of gas dynamics (Plooster, 1970). Previously, wires were passed through gels to investigate the nature of the shock wave (Blumenthal, 2012).

What would happen if there were no wire? Would the blast effect simply dissipate on the surface of the skin? There seems to be no suggestion in the medical literature that suggests that the pressure blast wave of a lightning strike would rip a cavity in human flesh. Some more rigorous scenarios and analysis would need to be presented. It is for this reason that another experiment had to be constructed without a wire path for the current.

The story of wet versus dry lightning strike victims also needed greater clarification. For example, why was more clothing damage seen by Ohashi et al. in the wet clothing victims (Ohashi, 2001)? Was the blast wave truly

reinforced by the concussive effect of water vaporization? And was there a difference between distilled water (rain water) and saline water (sweat)?

4.2.3 Materials and methods

A simple proof-of-concept experiment was designed to determine which theory makes for better prediction with regard to lightning explosive barotrauma. Previous experimental set-ups were examined (Uman, 1970; Plooster, 1970; McKelvie, 1980) and the 'sixth mechanism paper experiment' was created. Please refer Figure 4.14.

This experiment was created to test for the presence or absence of a blast wave surrounding lightning's luminous channel in air. The testing took place at the University of the Witwatersrand's School of Electrical and Information Engineering High Voltage Laboratory and utilised an 8/20 μ s current impulse generator. The magnitude of the current impulse was measured by means of a Pearson coil connected to a Rigol DS 1064B digital oscilloscope. An isolation transformer was used to protect the oscilloscope from any surges that may occur on the mains supply during the experiments. It must be noted that this wave form does not represent that of natural lightning, which has a longer rise and fall time.

The 8/20 μ s waveform is commonly used to simulate induced lightning currents and was decided upon for the purposes of this experiment. These waveforms are indicative of induced currents due to a nearby direct strike. The energy is less (due to shorter duration) and therefore seemed to be excellent for a proof-of-concept approach.

Some further considerations with respect to the waveform used in our experiment: The current waveform of a direct lightning strike is modelled as a 10/350 μ s waveform. This means that the rise time (time to get from 10% of peak to 90% of peak) is 10 μ s. The fall time (time to reach 50% of the peak value) is 350 μ s. This waveform, due to its long duration, delivers a significant amount of energy as one would expect from a direct lightning strike. In a laboratory environment, this energy is difficult to manage.

The experiment would consist of discharging high-voltage sparks through a 250 mm x 250 mm piece of dry graph paper, saline-soaked graph paper and distilled water-soaked graph paper, respectively. Distilled water was chosen, being the closest alternative to rain water. Saline water was chosen, being the closest alternative to sweat. The peak current versus the maximum diameter of tattering would then be plotted on the respective graph papers. All papers would be tested at generator charging voltages of 15 kV, 18 kV and 20 kV, respectively. This equated to peak currents of 24,5 kA, 29,2 kA and 32,5 kA, respectively. Maximum and minimum diameters were then measured with scientific callipers. Finally,

an average diameter for the irregular tears was determined using mathematical principles.

Due to the fact that risk is determined as distance from lightning's luminous channel, the perimeter length (circumference) of the tear was not measured.

If *sixth mechanism theory* (meaning a pressure blast wave around lightning's channel) were indeed a reality, all papers, wet and dry, conductive and non-conductive would show tearing and tattering.

If *flash moisture vaporization theory* were indeed a reality, only the wet papers would tear and tatter, or there would be more tearing and tattering in the wet papers.

The maximum radial diameters of the tearing and tattering would probably best give an idea as to within what range a human would be at risk and what would be the risk.

Obviously, a more comprehensive data set would be required to test the reliability and validity of the results; therefore preliminary findings are presented here.

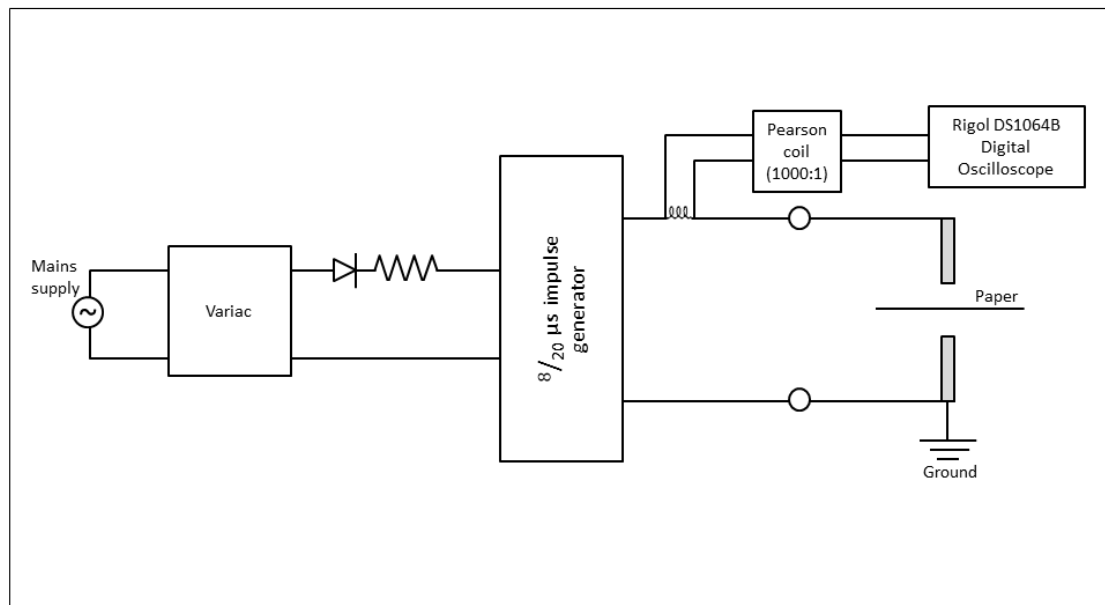

Figure 4.14: The 2014 'sixth mechanism paper experiment': Physical layout of current impulse generator and test object (graph paper)



Figure 4.15: The test box, specifically constructed to create a spark gap of 5mm.

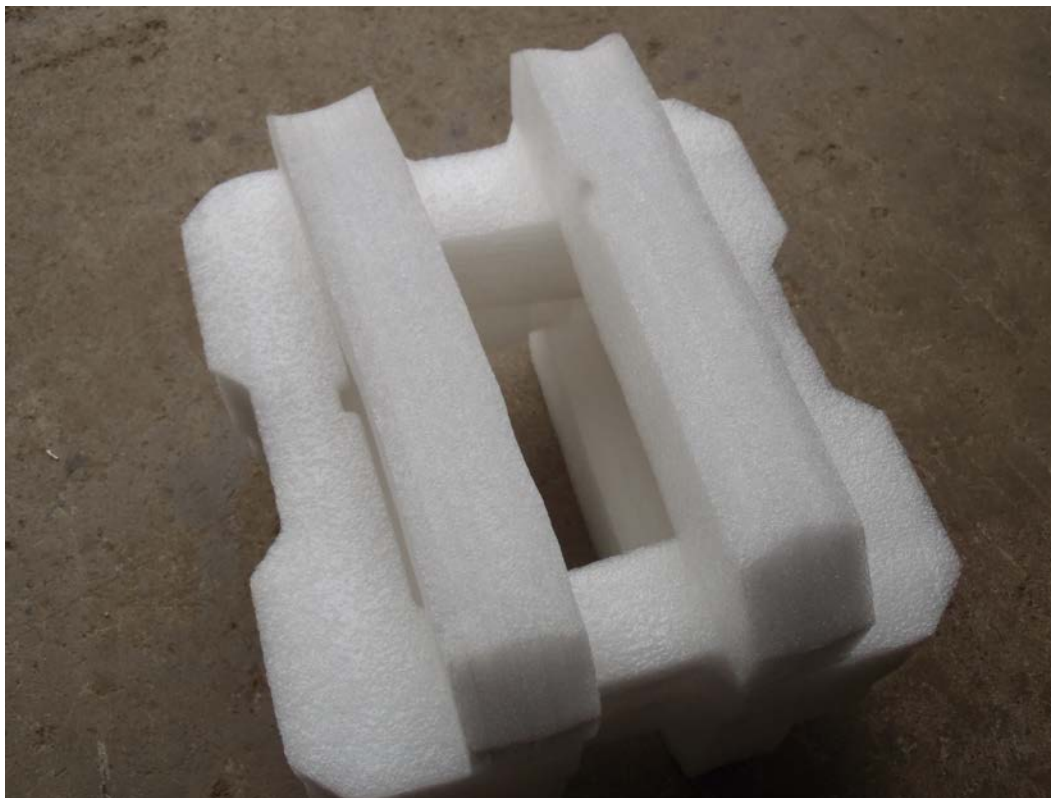

Figure 4.16: The polystyrene 'clamp' designed to clamp the graph paper and not cause any undue forces on the graph paper, thereby enabling the tearing and tattering to take place without any undue influence.

Figure 4.17 and Figure 4.18 show what happened to the graph paper after having been subjected to an impulse. The majority of knowledge related to lightning parameters has been derived by 'scaling up' the equivalent information obtained during experimentation with the use of long linear electrical discharges generated under laboratory conditions (Uman, 1970).

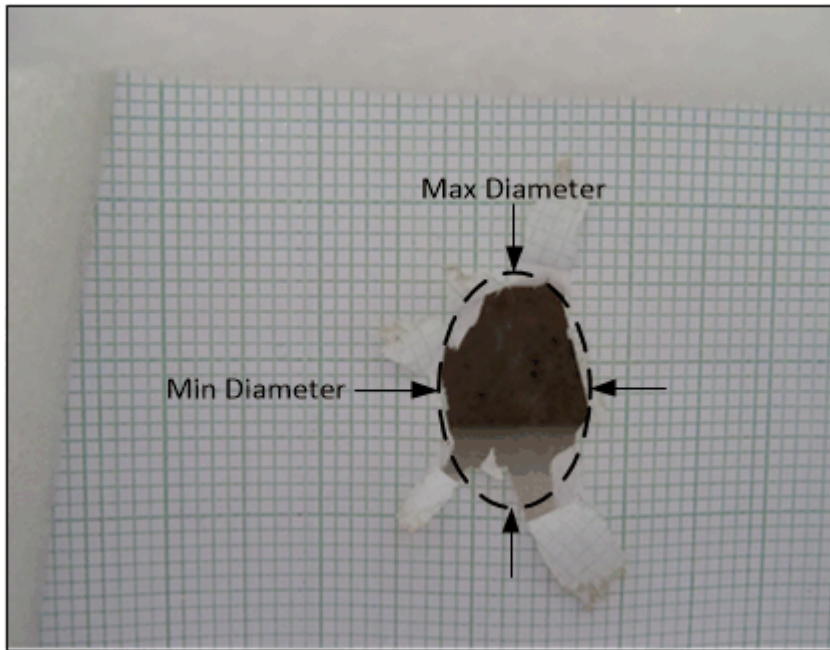

Figure 4.17: Tearing and tattering of dry graph paper to a maximum diameter of 29 mm. 15 kV. 24 kA.

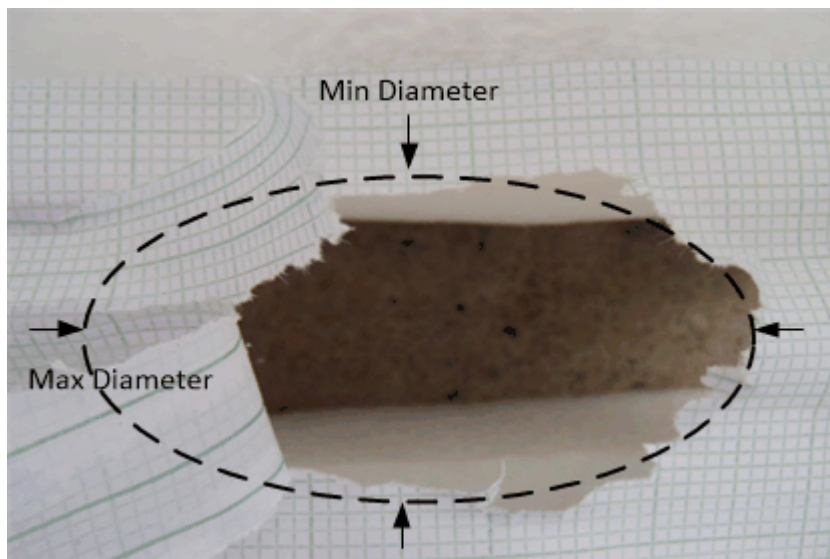

Figure 4.18: Tearing and tattering of saline-soaked graph paper to a maximum diameter of 80 mm. 20 kV. 32,8 kA.

4.2.4 Results

The graph illustrated in Figure 4.19 shows the maximum tearing diameters against the peak generated currents for dry, distilled and saline-soaked graph papers.

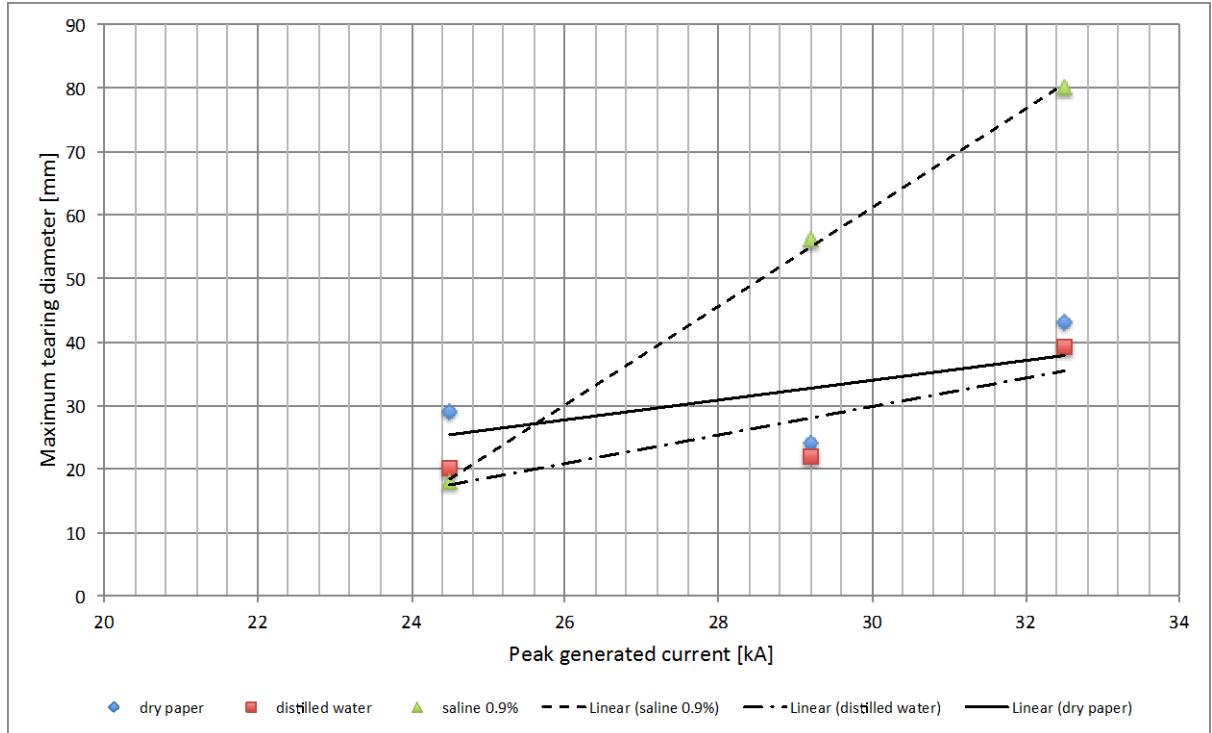

Figure 4.19: Trend lines showing significantly higher tearing of the paper soaked in 0.9% saline solution.

Further considerations regarding the graph illustrated in Figure 4.19: Trend lines showed significantly higher tearing of the paper soaked in 0.9% saline solution.

It can be seen that there is not much difference between the maximum tearing diameter for the dry paper and the paper soaked in distilled water. However, the tearing diameter was found to be significantly higher for the case of the paper soaked in the 0.9% saline solution.

Tearing and tattering occurred in dry-, distilled- and saline-soaked papers confirming the existence of a non-discriminant blast wave around a long, linear spark (lightning's luminous channel).

More tattering did however seem to occur in the saline-soaked paper, perhaps due to the conductive nature of saline. The saline-soaked paper probably 'held on' to more charge than the other specimens.

4.2.5 Discussion

“The temperature of the lightning bolt channel is raised to about 25 000 K (24727 °C) in a few microseconds. This causes the temperature around the channel to rise suddenly, meaning that the pressure in the channel suddenly increases to several atmospheres” (Cooray 2007: 387). Charles law dictates that the volume of a gas is directly proportional to its temperature, meaning the larger the temperature of a gas, the larger its volume. The combined and ideal gas laws therefore predict pressure changes with temperature changes. One can hear thunder from as far away as 25 km (Rakov, 2003), which means that there is obviously a tremendous amount of energy involved in the generation of thunder.

This sudden rise in volume causes a sudden cylindrical-shaped pressure shock wave, which may reach pressures of more than 10-20 atmospheres (1013,25 kPa – 2026,5 kPa) in the vicinity of the lightning bolt channel. This is enough energy to form a small crater in a concrete pavement (Blumenthal, 2012b).

“When a lightning flash is incident on rocky soil the electric current tends to follow the interstices between the rocks or cracks which are filled with moist soil. Rocks may be split asunder or even thrown aside with explosive violence” (Malan 1963: 164). Whether this is due to cracks being filled with the moist soil (flash moisture vaporization theory) or solely due to the lightning’s pressure blast wave (sixth mechanism theory) has been the topic of debate.

Lightning’s pressure blast wave has been known to tear and tatter clothing, fracture bones, rupture a person’s eardrums and damage their lungs. The blast causes a pocket of air behind the sternum (pneumomediastinum) (Halldorsson, 2004) and it may cause injury to the chest wall and lungs (Moulson, 1984). A more in-depth look at these specific injuries will take place Chapter 6.

Paradoxically, the human body seems to be both very robust and very fragile. Humans can survive relatively high blast overpressures without experiencing blast-related pathologies (Mason, 2000). Thus far, blunt force trauma injuries, torn and tattered clothing, fractures, traumatic perforation of tympanic membranes, lung contusion and haemorrhage, and pneumomediastinum have been documented in the medical literature. Aforementioned, appear to represent the documented risks of ‘sixth mechanism injuries’, seen in practice, to date (Blumenthal, 2012).

So how close does a person have to be to a lightning strike to be at risk? How far does this pressure blast wave extend? The findings reported in flash moisture vaporization theory can all adequately be explained by sixth mechanism theory. The purpose of the 2014 experiment was to

compare the one theory with the other theory and to determine which one makes better predictions.

If one knew the initial conditions (thermodynamics and flow parameters as a function of radius at selected instants of time) one could possibly have a numerical solution to this problem; however there are always varying initial conditions, for example the magnitude and strength of the lightning discharge.

Theoretically, one could take the 2014 sixth mechanism laboratory experiment results; together with the known medical literature; together with the known high-explosive overpressure constants and consequences - and then model the risks for natural lightning.

4.2.6 Conclusion

The tearing diameter in the laboratory experiment was found to be significantly higher for the case of the paper soaked in the 0.9% saline solution, which would appear to fit in with Ohashi and Kitigawa's experiments (Ohashi, 2001, 1986; Kitigawa, 1985). Yet, the tearing and tattering occurred in *all* the papers (dry-, distilled- and saline-soaked) suggesting the existence of a non-discriminant blast wave around a long, linear spark (lightning's luminous channel).

The data obtained from the 2014 'sixth mechanism paper experiment' seemed to align relatively well with the high-explosive overpressure observations noticed in the field.

In order to better understand these findings, a more critical look at flash moisture vaporization theory would have to take place (Chapter 5).

CHAPTER FIVE – ANOMALIES

This chapter will address anomaly-seeking research questions.

5.1 Sixth Mechanism Mimics

In other words, could any other natural phenomena mimic or simulate lightning explosive barotrauma?

The classical effects of lightning are well known in the literature such as the heat, direct current and flame effects. However certain aspects of lightning injuries and lightning damage to property are still shrouded in mystery and many myths prevail.

Multiple theories and propositions abound as to:

- Why lightning strike victims present with torn and tattered clothing?
- Why lightning victims sustain blunt force trauma injuries?
- Why lightning victims present with fractures?

Characterisation of lightning barotrauma is an important question, which merits investigation.

5.1.1 A review of flash moisture vaporisation theory

Regarding the damage caused to victims clothing, which typically presents as ruptures, tears and tatters. One proposition has been the flash vaporisation of moisture theory (Ohashi *et al.*, 2001). According to this theory, moisture in the clothing or on the victim's skin vaporises because of the passage of the lightning current. Damage to structures such as concrete or brick has also been argued to be feasible through this flash vaporisation of moisture theory. Internal pressure build-up in the material causes it to fracture and possibly result in shrapnel damage or injuries. There are also theories of thermal stresses imposed on the material due to thermal heating that can cause material fracture.

Ohashi and Kitigawa (Ohashi, 2001, 1986; Kitigawa, 1985) through process of elimination came to the conclusion that blast injury results from the explosive vaporization of superheated water along the path of the surface flashover.

Ohashi's paper (2001) focussed on three men who died upon being struck and who suffered a surface flashover spark along their wet body surface. These men were believed clinically to have sustained skull fractures. *Case 1* in their paper presented with blood from the left external auditory meatus which was believed to represent an intracranial haemorrhage secondary to a basilar skull fracture with tympanic rupture (an autopsy was not performed). *Case 2* showed a small amount of blood in the left external auditory meatus which was likely due to tympanic rupture, and a left temporal fracture was identified by radiography (autopsy was not performed). *Case 3* reported that haemorrhage was noted from the external auditory meatus, which suggested that intracranial haemorrhage

with tympanic rupture, basilar fracture and pulmonary haemorrhage had occurred (an autopsy had not been performed). Post mortem examinations were also not carried out on the four patients with fatal injuries in Ohashi's previous paper (Ohashi, 1986).



Figure 5.1: Photograph of a lightning victim showing blood at the external auditory meatus due to ruptured left tympanic membrane. (Photograph courtesy of dr R. Blumenthal, Department of Forensic Medicine, University of Pretoria).

Figure 5.1 shows bleeding from the external auditory meatus in a lightning strike victim from the Department of Forensic Medicine, University of Pretoria. Post mortem examination of aforementioned lightning strike victim demonstrated no base of skull fracture. The bleeding was due solely to a ruptured tympanic membrane. The force required to cause fractures to the skull needs to be discussed in this context. The tensile strength of the adult skull is in the order of 100-150 psi, the compressive strength varying from 5000 to 31 000 psi. A 'hinge' fracture of the base of the skull is where the fracture line runs from side to side across the floor of the middle cranial fossa, passing through the pituitary fossa in the midline, following the course of least structural resistance. This frequently continues symmetrically across the other middle fossa separating the base of the skull into two halves, usually being caused by a heavy blow on the side of the head; this lesion is sometimes called the 'motorcyclist's fracture' for obvious reasons. (Saukko, 2004). To date, there have been no peer-reviewed autopsy reports of basal skull fracture due to lightning in the forensic pathology literature.

Flash moisture vaporization theory has been proposed as possible mechanisms of clothing destruction; however three questions need to be raised regarding this theory:

1. Firstly, saline-soaked blotting paper was used in the flash moisture vaporization theory experiments. Human sweat is saline based, which is probably the reason behind this decision. If flash moisture vaporization theory were indeed a reality, then perhaps distilled

water- or rain water-soaked blotting paper ought to have been utilized in the original experiments.

2. Secondly, why are no forensic pathologists seeing *scald burn wounds* on lightning strike victims? Surely, superheated water would cause scald burns on the skin of lightning victims? Instead, forensic pathologists are seeing scorch burn wounds on the skin and torn-and-tattered clothing akin to explosive (blast) barotrauma.
3. Thirdly, findings in the rat may not simply be equated to findings in the human.

The findings reported in the flash moisture vaporization theory may all adequately be explained by sixth mechanism theory. However; sixth mechanism theory may make for better predictions in the field than flash moisture vaporization theory.

Nobu Kitigawa, in his response address for the award of medal in keraunomedicine (Kitawaga, 2003), stated that when some amount of water exists on the body surface, e.g., clothes are wet; the evaporation caused by surface discharge heat may exert concussive pressure on various organs and damage them. He concluded by saying that the mechanism of such injuries should be further investigated.

5.1.2 Startle reactions and reflex movements

Startle reactions and reflex movements from man-made and static electricity should always be kept in mind as a differential diagnosis.

"Startle, neural and muscular reactions often result in injuries in persons who have received a small electric shock. Electric currents can surprise a person, produce pain, and lead to a variety of events, including involuntary muscular contractions and resultant movements. These movements may cause the victim to fall and sustain blunt force trauma injuries" (Fish & Geddes, 2008: 429).

Strong muscle contraction from nerve or muscle stimulation exists. Abnormally strong contractions can result from electrical stimulation of nerves or muscles, as well as reactions to pain. Fractures and dislocations of shoulders from strong muscle contractions due to electric currents suggest that forces in these situations can be very great (Tomkins et al, 1990; Stueland et al, 1989; Beswick et al, 1982; Carew-McColl, 1980; Salem, 1983).

The possibility of tetanic muscle contraction as a cause of falls and blunt force trauma injury therefore exists. Fractures and shoulder dislocations have been reported following contact with voltage sources of 110-440 volts (Stueland et al, 1989; Beswick et al, 1982; Carew-McColl, 1980; Salem, 1982). Unilateral and bilateral shoulder dislocations can be associated with fractures of nearby bones, including the scapula. Literature reports have included cases of bilateral scapulae fracture (Beswick et al, 1982), bilateral shoulder dislocations (Carew-McColl, 1980) and bilateral anterior fracture-dislocation of the shoulder joints (Salem, 1982). Posterior shoulder dislocations occur in 2% to 5% of all acute shoulder dislocations. Mechanisms by which electric accidents might

produce a posterior shoulder dislocation are related to various possible electrical and fall-related events (Connoly, 1981; Daya, 1998). Lumbar bursa fracture due to low voltage shock has also been reported (Van den Brink, 1995).

Could the blunt force trauma injuries found on the bodies of lightning strike victims be the result of 'tetanic spasm' of large muscle groups and not lightning explosive barotrauma? It seems obvious that the lightning victim falls and then sustains injuries – such as the combined Bennet's fracture subluxation and scapho-trapezio-trapezoidal dislocation described by Kannan (2004). The question is whether the fall occurred due to lightning explosive barotrauma or due to tetanic spasm of a large group of muscles.

Would 'tetanic spasm' explain perforated eardrums (Blumenthal, 2000) or pneumomediastinum (Halldorsson, 2004)? The answer is very unlikely, as these injuries represent signs of explosive barotrauma phenomenon. This is not to say that tetanic spasm (as seen in electrocution) is not at play in lightning strike victims – however the *time* would be too short (milliseconds) to cause a muscle to sustain its contractile function and exert sustained and sufficient strength long enough to induce *full* flexion, *full* extension or an avulsion-type fracture.

5.1.3 Observer bias

Independent testing, on two separate occasions, by two different teams showed consistent results (Please refer to Annexure E and Annexure F).

Experiments using the same protocol as the original experiment published in the *American Journal of Forensic Medicine and Pathology* (Blumenthal, 2012a) were conducted by Jiyane and Hunt 19 November 2012 and again by NJ West in 1st August 2012.

Even though different conducting wires of different resistances were used (*Nichrome wire* versus *Copper wire*), the results remained consistent with the original findings, namely: Permanent cavity formation was demonstrated in the softer gelatine media and temporary cavity formation was demonstrated in the harder gelatine media.

Independent testing therefore ruled out observer bias.

CHAPTER SIX – DISCUSSION

This chapter will focus on aligning the medical and the lightning data.

6.1 Discussion of results

6.1.1 Could a 'pressure-shock wave' immediately surrounding lightning's luminous channel adequately and convincingly explain aforementioned curious injury phenomena?

The idea that there can be damage or injury due to lightning as a result of blast-type effects is not new. These blast type effects are seen in injuries sustained by some victims of lightning strikes as well as certain examples of property damage.

A review of the lightning literature and the medical literature was performed. Two novel experiments were designed, which helped confirm the sixth mechanism's existence. Its existence may now help explain some of the more curious lightning injury patterns seen on lightning-strike victims.

The sixth mechanism seems to be the most plausible, if not the best explanation as to the pathogenesis of aforementioned injuries. The most compelling evidence seems to be lightning-related barotrauma. In light of the data gathered and formulated in this thesis, there appears to be no better way of explaining these curious blast-related injuries and phenomena.

On the face of it, this research seems to have ruled out alternative explanations that might link the phenomenon with the outcome.

6.1.2 If this blast wave does exist, what does it look like?

Intuitively, one imagines the blast wave to be cylindrical and/or fusiform in shape. The 2012 experiments helped confirm this (Blumenthal, 2012a). The softer gelatine blocks captured the shape of the 'pressure-shock wave' immediately surrounding the discharge channel. The pressure shock wave was found to be cylindrical and/or fusiform in shape (please refer Figure 4.7).

According to Malan, the shock wave rapidly decays to a sound wave within metres (Malan, 1963). A deeper understanding of the acoustic image of thunder will hopefully further explain the answer to this question.

Thunder recordings at three or more stations were used by Rakov and Uman (2005) for the acoustic imaging of lightning channels. The time difference between the arrival of significant features at different microphones in a network, typically tens of meters apart, was used to determine the direction of the incoming sound wave at the network, and that directional ray was then mathematically traced back to the source

given the atmospheric conditions and the time of arrival at the network of the lightning electromagnetic signal and the particular acoustic feature.

“The thunder signal is a linear superposition of basically identical pressure pulses produced simultaneously by the deposition of a specified amount of energy into a large number of cylindrical segments connected in series and randomly orientated with respect to the average channel direction” (Rakov & Uman 2005: 387).

One must therefore keep in mind the non-linear and non-uniform nature of the lightning channel. Thinking ‘three-dimensionally’, and taking into account the tortuous nature of lightning’s channel, it becomes clear why the proposed appearance of lightning’s pressure blast wave is shown as intermittent cylindrical nodes expanding at different angles (please refer figure 4.1).

6.1.3 Within what range is one at risk and what is the risk?

Two main questions still remain regarding lightning explosive barotrauma, namely within what range is a human at risk, and what is the risk? The lightning data and the medical data were reviewed and aligned. The known data associated with lightning was compared with the known bomb–blast data. Findings now seem to present a picture as to the range and possible risks associated with lightning’s pressure blast wave.

By looking purely at the pathologies of trauma of lightning on the human body, keraunopathologists may now get a relatively good idea as to the possible overpressures and distances involved with regards to lightning explosive barotrauma in the field.

Cooray et al. reported that injuries can be caused by shock waves created by the lightning channel; although he did not commit to a specific distance within which a victim would be at risk from blast wave injury (Cooray, 2007).

Please refer to the adapted tables in Appendices H to K for damage approximations; high explosive overpressure constants and consequences; human injury in proximity to a small bomb; and the predicted injuries and fatalities from direct blast effect of explosions (Glasstone & Dolan, 1977; Kinney & Graham, 1985).

6.1.3.1 Aligning the otorhinological medical literature

There is evidence in the literature supporting the fact that lightning can rupture eardrums (Bellucci, 1983; Gordon, 1995; Jones, 1991; Bergstrom, 1974, Weiss, 1980; Kristensen, 1985; Glunic, 2001; Wright, 1974; Redleaf, 1993).

Good data for eardrum rupture therefore exists. By looking at the pathology of trauma of tympanic membrane rupture, keraunopathologists may now get a relatively good idea as to the possible overpressures and distances involved with regards to lightning explosive barotrauma in the

field. By aligning aforementioned medical data and the lightning data, it is now possible to get a relatively good idea of the theoretical risks involved (Malan, 1963; Lee, 1986; Zipf, 2007).

The medical ear, nose and throat (otorhinological) literature sometimes describes the tympanic membrane following lightning strike as '*a large tympanic membrane perforation with ossicular chain disruption*'. Proposed mechanisms of injury have included concussive 'blast' effect on the ear, 'direct' effect of electrical conduction, 'splash' effect, 'cylindrical shock wave of electrons' and/or direct 'thermal burn'. (Bellucci, 1983; Soltermann, 1991; Gordon, 1995; Jones, 1991; Bergstrom, 1974; Weiss, 1980; Kristensen, 1985; Glunic, 2001; Redleaf, 1993; Wright, 1974). One theory even places emphasis on the special sense orifices as portals of entry in lightning injury (Andrews and Darveniza 1992, 1994).

The human tympanic membrane is able to withstand a limited amount of over pressure before failure. Overpressures are required to produce minor, moderate and major eardrum ruptures.

Rupture of the normal eardrum is a function of age as well as of the effective blast pressure. Failures have been reported at overpressures as low as 5 pounds per square inch (34.47 kPa) ranging up to 40 or 50 pounds per square inch (275.79 to 344.73 kPa).

As mentioned earlier, calculations by Hill (1971) showed that the overpressure within a few centimeters of the lightning channel can reach about 10-20 atmospheres (1013 kPa to 2026 kPa).

A study by Richmond suggests a minimum threshold of about 20 kilopascals to produce minor eardrum ruptures (Richmond, 1989). One can therefore deduce from human victims with tympanic membrane rupture, that lightning's blast wave must have had a minimum over pressure of approximately 20 kPa.

6.1.3.2 Aligning the chest and the lung medical literature

There appears to be relatively good data for chest and lung damage by blast waves in the literature.

The bomb blast literature shows that the threshold for lung damage is in the range of 12 psi (8 psi-15 psi) (82.73 kPa) and the range for severe lung damage is in the range of 25 psi (20 psi-30 psi) (172.36 kPa) (Glasstone & Dolan, 1977).

Pneumomediastinum and bleeding lung in a tracheostomized patient have both been reported (Halldorsson, 2004; Soltermann, 1991; Moulson, 1984; Bouwen, 1997).

The threshold for lung damage occurs at about 103.42 kilopascals blast over pressure (Glasstone & Dolan, 1977). Posttraumatic pneumomediastinum is not a cause for alarm amongst clinicians (Bouwen,

1997). Pneumediastinum is therefore generally not considered a fatal injury.

The table in Appendix J suggests that lung damage requires approximately (29.0 – 72.5 psi) 200 to 500 kPa to induce.

One can therefore deduce from human victims with chest and/or lung trauma, that lightning's blast wave must have had a minimum over pressure of approximately 200 to 500 kPa.

6.1.3.3 Aligning the further medical literature

Lightning has also been implicated in the fractures of bones and rupture of internal organs (Kannan, 2004; Graber, 1996). Unfortunately, no associated overpressure data could be found in the literature in this regard.

In addition to causing damage in the ear and eyes, this shock wave can also cause damage to other internal organs such as the spleen, liver, the lungs, and the bowel tract (Barmate, 2014). Moreover, it may displace the victim suddenly from one place to another causing head and other traumatic injuries (Cooray, 2007). Once again, no associated over pressure data could be found in the literature in this regard.

6.1.3.4 Aligning the data to determine risk of blast-related disfigurement

There is no evidence to suggest that lightning victims suffer severe blast-related disfigurement. There is no evidence to suggest that lightning would rip a cavity in human flesh. The human body can survive relatively high blast overpressures without experiencing barotrauma (Mason 2000: 84).

When looking at tentative criteria for direct (primary) blast effects in man from fast-rising, long-duration pressure pulses (such as a bomb explosion), the threshold for lethality would be in the 40 psi (30 psi – 50 psi) (275.79 kPa) range. Fifty percent lethality would be in the 62 psi (50 psi -75 psi) (427.47 kPa) range. One-hundred percent lethality would be in the 92 psi (75psi – 115 psi) (634.31 kPa) range. About 100 psi (690 kPa) is the minimum threshold for serious damage to humans (Glasstone & Dolan, 1977; Kinney & Graham, 1985; Saukko, 2004; Mason, 2000).

A 35-45 psi overpressure (241.31 to 310.26 kPa) may cause 1% fatalities, and 55 to 65 psi overpressure (379.21 to 448.15 kPa) may cause 99% fatalities (Glasstone & Dolan, 1977).

Should a forensic pathologist find a human barotrauma victim with disfiguring trauma, he/she could theoretically deduce that the blast wave must have had a minimum over pressure of approximately 690 kPa.

As forensic pathologists we would need to know within what range a human would be at risk.

6.1.3.5 Aligning the data to determine the possible range of risk

It is theoretically possible to estimate at what range a human would be at risk from lightning's pressure blast wave.

A 4.5kg TNT equivalent bomb would rupture an eardrum of a 70 kg man within 10 meters; lung damage would occur at about 5 meters and the body would be injured at about 3 meters (Glasstone & Dolan, 1977).

A keraunopathologist in the field could therefore crudely deduce the distance from the channel based on the victim's pathology of trauma.

6.2 Limitations of this research

There are indeed many unanswered questions that have emerged that will require research beyond the limits of the reported undertaking. As a forensic pathologist I have a certain skill set, which has been applied to the development of this thesis. There is still much to discuss, from a medical point of view, which will surely lead to some debate. The real test, however, will lie in the duplication of these results in other laboratories, in practical assessment and at autopsy.

There were obstacles and challenges encountered in this research, for example the lenses of other disciplines were required. Researchers whose backgrounds are in different disciplines generally use different methods and have different interests toward their object of study. Such differences often allow them to see things that might not be recognised or might appear inconsequential to an insider.

6.3 Implications / Relevance of this research

Understanding the physics of a lightning strike can better help the medical practitioner appreciate the mechanisms by which lightning injures and kills its victims. For example, the electrothermal and blast components of a lightning strike may lead to different pathologies of trauma. Medical practitioners should therefore look for the signs and symptoms and be aware of lightning explosive barotrauma on their lightning strike patients.

Knowledge of the mechanisms of lightning injury might affect the treatment regimens of clinicians (Blumenthal, 2014a). Awareness and consideration of the sixth mechanism may therefore affect medical practice.

An understanding of the concept of the sixth mechanism may have relevance and applications in the field of lightning protection.

Electrical safety guidelines with regards to arc flash and arc blast, may benefit from the findings presented within this thesis.

If one looks again at the case reports of structural damage caused by lightning (McKechnie and Jandrell, 2008; Plumer, 2012), mention was not

made of whether or not the damaged structures had inward- or outward bevelling and in what direction the structures 'punctured'. This information may be relevant and have implications for future structural work.

Researchers, engineers, medical practitioners, veterinary surgeons, pathologists, agriculturalists, meteorologists, building and structural scientists and all those active in the field of lightning physics and lightning protection, directly or indirectly, may find the concept of this research to be of value.

Experts in these various fields ought to consider and look for signs of the sixth mechanism when practising their respective disciplines.

6.4 Recommendations / Scope for further research

6.4.1 Future field test experiments

The findings presented in this thesis do however pose further questions such as to what parameters, such as distance to strike and current level, are necessary to see such blast damage and/or injuries. The answers to these questions are not trivial and the real test will lie in the duplication of these results in other laboratories, in practical field assessment and at autopsy.

Objective 6.1.3 could, for example, be investigated further using triggered lightning and simple rupture disk pressure monitors or clothed-mannequins in close proximity. The range and risk involved would depend on the magnitude of the current of the lightning bolt concerned. This kind of research would better be able to address the risks involved with 'natural' lightning.

6.4.1 Future laboratory test experiments

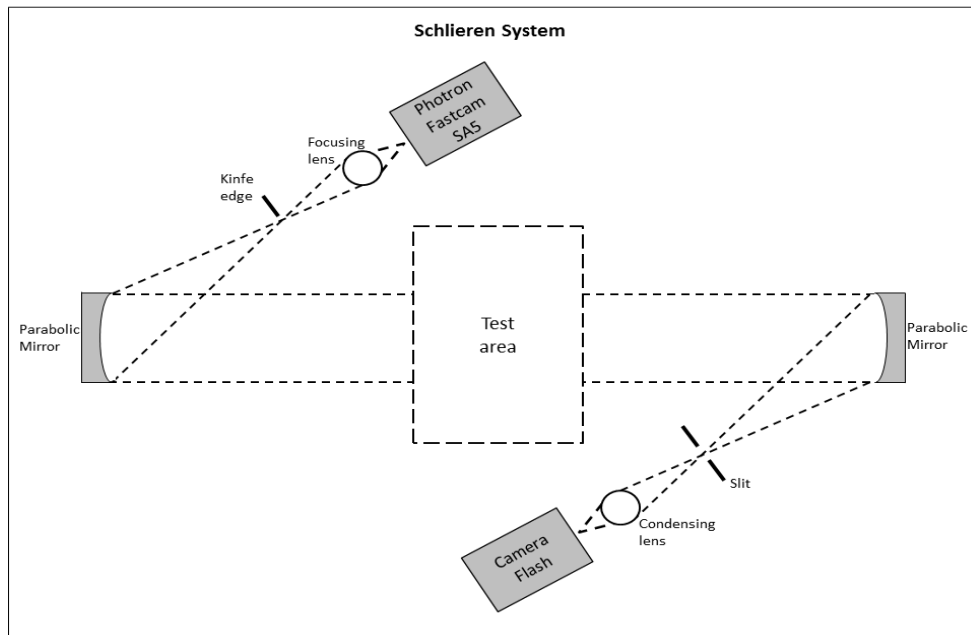

Figure 6.1: Proposed Z-configuration Schlieren test to photograph the lightning blast wave around a spark.

Figure 6.1 shows a Z-configuration Schlieren photography set-up to try and photograph lightning's pressure shock wave. Schlieren photography is a visual process that is used to photograph the flow of fluids of varying density, invented by the German physicist August Toepler in 1864. It is used to study supersonic motion, and is widely used in aeronautical engineering to photograph the flow of air around objects. Perhaps further research into lightning shock waves could utilize this testing approach.

6.4.2 Future prospective multi-disciplinary research studies

Retrospective research into lightning fatality victims has served to provide a broad generalised overview of the discipline. However, the real work lies in *prospective multi-disciplinary lightning research*. Owing to the fact that lightning fatality incidents are relatively rare compared to other pathologies, multi-centre, prospective, multi-disciplinary, keraunopathology research projects remain the only way forward. If any progress is to be made in keraunomedicine and keraunopathology academic centres of excellence around the world should thoroughly investigate their respective lightning fatality cases. CT and MRI scanning of lightning fatality victims may yield better results than autopsy examination.

6.4.3 Future numerical solutions

If one knew the initial conditions of the lightning stroke (the thermodynamics and flow parameters as a function of radius at selected instants of time) then one could possibly have a numerical solution to this problem; however there are always varying initial conditions, for example the magnitude and strength of the lightning discharge.

6.5 In closing

This thesis has looked at the testimonial evidence and the physical evidence of lightning's blast wave from a forensic pathologist's perspective.

6.5.1 The contribution of this thesis is therefore the following:

- The sixth mechanism may be thought of as an umbrella term for all those injuries caused as a direct or indirect result of lightning explosive barotrauma.
- Whereas lightning explosive barotrauma has been known to exist for some time, the precise risks associated with it have been generally unknown.
- By looking exclusively at the pathology of trauma of lightning on the human body, forensic pathologists may now get a relatively good idea as to the possible overpressures and distances involved with regards to lightning explosive barotrauma.
- In closing, lightning's pressure blast wave does appear to have significant injury implications associated with it.

REFERENCES

- Anderson, R.B. and Carte, A.E. (1989), 'Struck by lightning', *Archimedes*, August, pp. 25 – 29.
- Anderson, R.B. (2001), 'Does a fifth mechanism exist to explain lightning injuries?' *IEEE Engineering in Medicine and Biology*, vol. 20, no. 1, pp. 105 – 116.
- Anderson, R.B., Jandrell, I.R. and Nematswerani, H.E. (2002), 'The upward streamer mechanism versus step potentials as a cause of injuries from close lightning discharges"', *The Transactions of the South African Institute of Electrical Engineers*, vol. 93, no. 1, pp. 33-43.
- Andrews, C.J. (1989), 'Telephone-mediated Lightning Injury', An Australian Survey, *The Journal of Trauma*, vol. 29, no. 5, pp. 665 – 671.
- Andrews, C.J. and Darveniza, M. (1992), 'Further study of the functional and structural changes after lightning strike with special emphasis on special sense orifices as portals of entry', 9th Int. Conf. Atmosph. Elec., June 15-19, (St Petersburg, Russia, Borisenkov, E., A.I. Voelkov Main Geophysical Observatory, St. Petersburg).
- Andrews, C.J. and Darveniza, M. (1994), 'Functional and structural changes after lightning strike with emphasis on possible portals of entry', APERI Conf. on Lightning and Mountains (Chamonix-Mont Blanc, APERI, Paris France).
- Auerbach, PS. (2012). '*Wilderness Medicine*', Sixth Edition, Elsevier Saunders. Philadelphia. pp. 60 - 101.
- Barmate, N.S., Tumram, N.K., Singh, R.K., Shrigiriwar, M.B. (2014). 'A rare case of blast effect by lightning', *Journal of Forensic Research*, vol. 5, issue. 6, pp. 248.
- Becerra, M., Cooray, V. (2009), 'On the interaction of lightning upward connecting positive leaders with humans,' *IEEE Transactions on Electromagnetic Compatibility*, vol. 51, no. 4, pp. 1001 – 1008.
- Bellucci, R.J. (1983), 'Traumatic injuries of the middle ear', *Otolaryngeal Clinics of North America*, vol. 16, no. 3, pp. 633 – 650.
- Bergstrom, L., Lewis, M., et al. (1974), 'The lightning damaged ear', *Archives of Otolaryngology*, August, vol. 100, pp. 117 – 121.
- Beswick, D.R., Morse, S.D., & Barns, A.U. (1982), 'Bilateral scapular fractures from low-voltage electrical injury', *Annals of Emergency Medicine*, vol. 11, pp. 676-677.

Blumenthal, R. (2003), 'Lightning fatalities on the South African Highveld – A retrospective descriptive study 2001 – 2004', Oral presentation, International Congress on Lightning and Static Electricity (ICOLSE) – Blackpool, UK, 16-18 September 2003, Paper I0-35.

Blumenthal, R. (2005), 'Lightning fatalities on the South African Highveld – A retrospective descriptive study 1997 – 2000', *The American Journal of Forensic Medicine and Pathology*, vol. 26, no. 1, pp. 66 – 69.

Blumenthal, R. (2006), 'When thunder roars – go indoors! Lightning autopsy guidelines', *South African Medical Journal*, January, vol. 96, no. 1, pp. 38 – 39.

Blumenthal, R., Jandrell, I.R., West, N.J. (2012a), 'Does a sixth mechanism exist to explain lightning injuries? Investigating a possible new injury mechanism to determine the cause of injuries related to close lightning flashes', *The American Journal of Forensic Medicine and Pathology*, vol. 33, no. 3, September, pp. 222-226.

Blumenthal R. (2012b), 'Secondary missile injury from lightning strike', *The American Journal of Forensic Medicine and Pathology*, vol. 33, no. 1, March, pp. 83 - 85.

Blumenthal, R. (2012c), 'The forensic investigation of fatal lightning strike victims reconsidered and revised', Oral presentation, *International Conference on Lightning Protection*, Vienna, Austria 2-7 September 2012, Conference Proceedings, Paper 233.

Blumenthal, R., Trengrove, E., Jandrell, IR., Saayman, G. (2012d) 'Lightning medicine in South Africa', *South African Medical Journal*, July, vol. 102, no.7, pp. 625 - 626.

Blumenthal, R. (2014a), 'Lightning medicine in rural practice', *Journal of Neurosciences in Rural Practice*, Editorial, October – December, vol. 5, no. 4, pp. 325.

Blumenthal, R., West, N.J. (2014b), 'Investigating the risk of lightning's pressure blast wave', *South African Journal of Science*, Accepted for publication 9th August 2014.

Bouwen, L., Bosmans, E., 'Posttraumatic pneumomediastinum: not always a cause for alarm', *Acta chirurgica Belgica Société belge de chirurgie*, vol. 97, pp. 145-147.

Brode, H.L. (1956), 'The Blast Wave in Air Resulting from a High Temperature, High Pressure Sphere of Air', Research Memorandum RM-1825-AEC, The Rand Corporation, Santa Monica, California, 72 page paperback.

Budenstein, P.P. (1974), 'Dielectric breakdown in solids', technical report RG-75-25, US Army Missile Command, December 20, 1974.

INTERNET. <http://www.capturedlightning.com/Papers/a012177.pdf>.
Cited 30 March 2014.

Carew-McColl, M. (1980), 'Bilateral shoulder dislocations caused by electric shock', *British Journal of Clinical Practice*, vol. 34. pp. 251 - 254.

Centres for Disease Control and Prevention (CDC). Atlanta. (2003-2006), 'Explosions and blast injuries: A primer for clinicians',
INTERNET. <http://www.bt.cdc.gov/masscasualties/explosions.asp>.
Cited 30 March 2014.

Cherington, M., et al (1999), 'Closing the gap on the actual numbers of lightning casualties and deaths', Preprints, 11th Conference on Applied Climatology, Dallas, January 10-15. Boston, 1999, American Meteorological Society.

Cherington, M., Kurtzman, R. (2001), 'Mountain medical mystery', *The American Journal of Forensic Medicine and Pathology*, vol. 22, no. 3, pp. 296 - 298.

Connolly, J.F. (1981), '*DePalma's. The management of fractures and dislocations*'. Philadelphia, WB Saunders, pp. 632.

Cooper, M.A. (2002), 'A fifth mechanism of lightning injury', *Academic Emergency Medicine*, vol. 9, February, pp. 172 - 174.

Cooper, M.A., & Holle R.L. (2008), 'Mechanisms of lightning injury should affect lightning safety messages', International Lightning Detection Conference, Tucson AZ, April.

Cooper, M.A., & R.L. Holle. (2010), 'Mechanisms of lightning injury should affect lightning safety messages', Preprints, International Lightning Meteorology Conference, Orlando, FA, April 21-22, 2010, Vaisala, pp. 5.

Cooray, V., Cooray, C., Andrews, C.J. (2007), 'Lightning caused injuries in humans', *Journal of Electrostatics*, vol. 65. pp. 386 – 394.

Critchley, M. (1932), 'The effects of lightning, with special reference to the nervous system', *Bristol medico-chirurgical Journal*, vol. xlix. pp. 285.

Critchely, M. (1934), 'Neurological effects of lightning and of electricity', *The Lancet*, vol. 1. pp. 68 – 72.

Cullis, I.G. (2001), 'Blast waves and how they interact with structures', *Journal of the Royal Army Medical Corps*, vol. 147. pp. 16 - 26.

Damjanov, I. and Linder, J. (1996), '*Anderson's Pathology*', Tenth Edition, Mosby Publishers, St. Louis, Missouri.

- Daya, M. (1998), 'Shoulder', In: Rosen, P. and Barkin, R. eds. 'Emergency Medicine, Concepts and Clinical Practice', Fourth Edition, Mosby Publishers, St. Louis, Missouri, pp. 730.
- Dickson, A., Grant, M.D. & Jandrell, I.R. (2012), 'Lightning risk analysis: case study of endangered animals', Oral presentation, *International Conference on Lightning Protection*, Vienna, Austria 2-7 September 2012, Conference Proceedings.
- Elsayed, N.M., & Atkins, J.L. (2008), 'Explosion and Blast-Related Injuries, Effects of Explosion and Blast from Military Operations and Acts of Terrorism', Elsevier Academic Press, ISBN 13: 978-0-12-369514-7.
- Elsom, D.M. (2001), 'Deaths and injuries caused by lightning in the United Kingdom: analysis of two databases', *Atmospheric Research*, vol. 56, pp. 325 – 334.
- Fackler M.L., Malinowski J.A. (1985), 'The wound profile: a visual method for quantifying gunshot wound components', *Journal of Trauma*, vol. 25, no. 6, pp. 522 - 529.
- Fish, R.M., Geddes, L.A. (2008), 'Electrical Injuries, Medical and Bioengineering Aspects, Second Edition,' *Lawyers & Judges Publishing Company Incorporated*, Tucson, AZ, ISBN 1 933264 63 2, pp. 431 – 432.
- Furuta, J. and Okamoto, S., (1962), 'Radiation damage of shielding glass window', *Annals of the Department of Radiation*, Centre Osaka Prefect, vol. 2, Receipt date: 31-Dec-62.
- Glasstone, S. and Dolan, P.J. (1977), 'The Effects of Nuclear Weapons', Third Edition, The United States Department of Defence and the United States Department of Energy, pp. 80 – 96.
- Glunic, I., Roje, Z. (2001), 'Ear injury caused by lightning: Report of 18 cases', *The Journal of Laryngology and Otology*, January, vol. 115. pp. 4 – 8.
- Gordon, M.A., Silverstein, H., et al. (1995), 'Lightning injury of the tympanic membrane', *The American Journal of Otology*, vol. 16, no. 3, May, pp. 373 – 376.
- Gradwohl, R.B.H., Camps, F.E., Robinson, A.E., Lucas, B.G.B. (1976), 'Gradwohl's Legal Medicine – Third Edition', John Wright & Sons Ltd., Bristol, Chapter 1.
- Grant, M.D., Tordiffe, S.W., Blumenthal, R. (2012), 'Case study of lightning-caused death of critically endangered *Tragelaphus Sp*', Oral presentation, *31st International Conference on Lightning Protection*, Vienna, Austria, 2-7 September 2012, Conference Proceedings, pp. 1 – 5.

Halldorsson, A., & Couch M.H. (2004), 'Pneumomediastinum caused by a Lightning Strike', *Journal of Trauma*, vol. 57, pp. 196 – 197.

Hickman, B (1999-2012), INTERNET.
<http://www.capturedlightning.com> Cited 30 March 2014.

Hickman, B (2013), INTERNET.
<http://www.capturedlightning.com/frames/lichtenbergs.html#Measurements> Cited 30 March 2014.

Hill, R.D., (1971), 'Channel heating in return-stroke lightning', *Journal of Geophysical Research*, vol. 76, no. 3, pp. 637-645.

Holle, R.L., López, R.E., Navarro, B.C. (2005), 'Deaths, injuries, and damages from lightning in the United States in the 1890s in comparison with the 1990s', *Journal of Applied Meteorology*, vol. 44. pp. 1563 – 1573.

Holle, R.L., (2008), 'Annual rates of lightning fatalities by country', Preprints, International Lightning Detection Conference, April 21-23, Tucson, Arizona, Vaisala, pp. 14.

Holle, R.L., (2011), 'Recent studies of lightning safety and demographics', Preprints, 5th Conference on the Meteorological Applications of Lightning Data, January 23-27, Seattle, Washington, American Meteorological Society, pp. 19.

Horrocks, C.L. (2001), 'Blast injuries: Biophysics, pathophysiology, and management principles', *Journal of the Royal Army Medical Corps*, vol. 147, pp. 28 - 40.

Jansen, W., (1984), 'Death through lightning stroke. Wave-like arrangement of myocardial cells', in: 'Forensic Histopathology', Springer-Verlag Publishers, ISBN 0-387-12466-7, pp. 271.

Jellinek, S., (1932), 'Die elektrischen Verletzungen', Leipzig.

Jones, D.T., Ogren, F.P., et al. (1991), 'Lightning and its effects on the auditory system', *Laryngoscope*, vol. 101, pp. 830 – 834.

Jumbelic, M.I. (1995), 'Forensic perspectives of electrical and lightning injuries', *Seminars in Neurology*, vol. 15, no. 4, December, pp. 342 – 349.

Jussila, J. (2005), 'Measurement of kinetic energy dissipation with gelatine fissure formation with special reference to gelatine validation', *Forensic Science International*, vol. 150, pp. 53 – 62.

Kannan, R.Y., Chester, D.L., et al. (2004), 'Combined Bennet's fracture subluxation and scapho-trapezio-trapezoidal dislocation secondary to lightning strike', *The Journal of Trauma*, vol. 57. pp. 1351 – 1353.

Kinney, G.F., Graham, K.J. (1985), 'Explosive Shocks in Air, Second Edition', Springer, Verlag, New York.

Kitigawa, N. (2003), 'Response address for the award of medal in keraunomedicine', International Conference on Lightning and Static Electricity, September 16-18, Blackpool, England, Royal Aeronautical Society.

Kitigawa, N., Turumi, S., Ishikawa, T., Ohashi, M., (1985), 'The nature of lightning discharges in human bodies and the basis for safety and protection', In Proceedings of the 18th *International Conference on Lightning Protection*, Berlin, VDE-VERLAG GmbH, Session 6.7, pp. 435-438.

Kristensen, S., Tvetenas, K. (1985), 'Lightning-induced acoustic rupture of the tympanic membrane – A report of two cases', *The Journal of Laryngology and Otology*, July, vol. 99. pp. 711 – 713.

Langworthy, M.J., Sabra, J., & Gould, M. (2004), 'Terrorism and blast phenomena: Lessons learned from the attack on the USS Cole' (DDG67), *Clinical Orthopaedics & Related Research*, vol. 422. pp. 82 - 87.

Lee, R.H., (1986), 'The shattering effect of lightning - pressure from heating of air by stroke current', *IEEE Transaction on Industry Applications*, IA-22, no. 3, May/June, pp. 416-419.

Lee, R.H., (1987), 'Pressures developed by arcs', *IEEE Transaction on Industry Applications*, IA-23, no.4, July/August, pp.760-763.

Lloyd, J.M Jr. & Budenstein, P.P., (1977), 'Effects of excess charge density on dielectric breakdown in solids', Ph.D. Thesis. Final Report Auburn Univ., AL. Dept. of Physics. Publication Date: 11/1977, Electronics and Electrical Engineering, pp. 125 - 127 (regarding a possible explanation for beading). INTERNET.
<http://www.capturedlightning.com/Papers/a048267.pdf>. Cited 30 March 2014.

López, J., Urgoiti, V., González, M., Aranda, J.A., Gaztelumendi, S., and Anitua, P. (2013), Brief communication. 'A multi-disciplinary approach to a side-flash lightning incident to human beings in the Basque Country', *Natural Hazards and Earth System Sciences*, vol.13, pp. 721 - 726.

Mahajan, A.L., Rajan, R. & Regan, P.J. (2008), 'Lichtenberg figures: Cutaneous manifestation of phone electrocution from lightning', *Journal of Plastic, Reconstructive & Aesthetic Surgery*, vol. 61, Issue. 1, January, pp. 111 - 113.

Malan, D.J. (1963), '*Physics of Lightning*', The English Universities Press Limited, London, UK, pp. 164.

- Marshall, T.K. (1976), 'Deaths from explosive devices', *Medicine Science and the Law*, vol. 16. pp. 235 - 239.
- Mason, J.K., & Purdue, B.N. (2000), '*The Pathology of Trauma*', Third Edition, Arnold Publishers, Chapter 7.
- Mayo, A., & Kluger Y. (2006), 'Terrorist bombing', *World Journal of Surgery*, vol. 13, pp. 1-33.
- McKechnie, I.S. & Jandrell, I.R. (2008), 'An analysis of structural damage caused to a club house building as a result of a direct lightning strike', 29th International Conference on Lightning Protection, 23rd-26th June 2008, Uppsala, Sweden.
- McKelvie, P.I., Page, N.W., & Mackerras D. (1980), 'Strength of shock waves produced by electrical discharges', 7th Australian Hydraulics and Fluid Mechanics Conference, Brisbane, 18-22 August 1980, pp. 313 – 316.
- Moulson, A.M. (1984), 'Blast injury of the lungs due to lightning', *British Medical Journal*, vol. 289, pp. 1270-1271.
- Murty, O.P. (2009), 'Lightning fatality with blast, flame, heat and current effects: A Macroscopic and Microscopic View', *Journal of Forensic and Legal Medicine*, vol. 16, pp. 162 - 167.
- Ohashi, M., Kitagawa, N., Ishikawa, T. (1986), 'Lightning injury caused by discharges accompanying flashovers – a clinical and experimental study of death and survival', *Burns*, vol. 12, no. 7, pp. 496 – 501.
- Ohashi, M., Hosoda, Y., Fujishiro, Y, Tuyuki, A., Kikuchi, K., Obara, H., Kitigawa, N. & Ishikawa, T. (2001), 'Lightning injury as a blast injury of skull, brain, and visceral lesions: clinical and experimental evidences', *The Keio Journal of Medicine*, vol. 50, no. 4, pp. 257 – 262.
- Page, N.W., & McKelvie, P.I. (1977), 'Shock wave generated by spark discharge', 6th Australasian Hydraulics and Fluid Mechanics Conference, Adelaide, Australia.
- Panse, F. (1930), 'Die schädigungen des nervensystems durch technische elektrizität', Berlin; also *Monatsschrift fur psychiatrie und neurologie*,(1925), lix., pp. 323.
- Plooster, M.N. (1968), 'Shock waves from line sources', National Centre for Atmospheric Research, Boulder Colorado, Tech. Note NCAR-TN-37.
- Plooster, M.N. (1970), 'Shock waves from line sources, Numerical solutions and experimental measurements', *The Physics of Fluids*, vol. 13, no. 11, pp. 2665 – 2675.

- Plumer, J.A. (2012), 'Laboratory test results and natural lightning strike effects: How well do they compare', Invited Lecture, International Conference on Lightning Protection (ICLP), Vienna, Austria, 2-7 September.
- Primeau, M., Engelstatter, G.H. & Bares, K.K., (1995), 'Behavioural consequences of lightning and electrical Injury', *Seminars in Neurology*, vol. 15, no. 3, September 1995, pp. 1 – 11.
- Rakov, V.A., & Uman, M.A. (2003), '*Lightning. Physics and Effects*', Cambridge University Press, pp. 378 & pp.387.
- Redleaf, M.I., McCabe, B.F. (1993), 'Lightning injury of the tympanic membrane', *Annals of Otology Rhinology and Laryngology*, vol. 102, pp. 867 – 869.
- Resnik, B.I., & Wetli C.V. (1996), 'Lichtenberg figures', *American Journal of Forensic Medicine and Pathology*, vol. 17, no. 2, pp. 99 - 102.
- Rich, N.M. (1967), 'Shrapnel wounds', *Journal of the American Medical Association*, vol. 202, no. 3, pp. 245.
- Richmond, D.R., Yelverton, J.T., Fletcher, E.R., Phillips Y.Y. (1989), 'Physical correlates of eardrum rupture', *The Annals of Otology, Rhinology, & Laryngology, Supplement*, vol. 140, pp. 35-41.
- Ritenour, A.E., Morton, M.J., McManus, J.G., Barillo, D.J., Cancio, L.C. (2008), 'Lightning injury: A review', *Burns*, vol. 34, pp. 585-594.
- Salem, M.I. (1983), 'Bilateral anterior fracture-dislocation of the shoulder joints due to severe electrical shock', *Injury*, vol. 14, pp. 361 - 363.
- Sasser, S.M. (2001), 'Blast injuries', *The Turkish Journal of Emergency Medicine*, vol. 1, pp. 97 - 98.
- Saukko, P. Knight, B. (2004), '*Knight's Forensic Pathology*', Third Edition, Arnold Publishers, Chapter 12, pp. 336 - 337.
- Schwär, T.G., Loubser, J.D., Olivier, J.A. (1988), 'The Forensic ABC in Medical Practice, A Practical Guide', *Haum Educational Publishers*, Pretoria, ISBN 0 7986 1878 7, pp. 222 and pp. 231 – 233.
- Sellier, KG., & Kneubuehl, BP. (1994), '*Wound Ballistics and the Scientific Background*', Elsevier Science Ltd, Oxford, GB.
- Silbergleit, A.K., Trenkner, S.W. (1988), 'Dysphagia following lightning strike', *Dysphagia*, vol. 2, pp. 228-229.
- Smith, S. (1951), 'The history and development of forensic medicine', *British Medical Journal*, vol. 1, pp. 599-607.

- Soltermann, B., & Frutiger, A. (1991), 'Lightning injury with lung bleeding in a tracheotomized patient', *Chest*, pp. 240 –242.
- Stueland, D.J., Stanas, P., Welter, T.M., & Cleveland, D.A. (1989), 'Bilateral humerus fractures from electrically induced muscular spasm', *Journal of Emergency Medicine*, vol. 7, pp. 457 - 459.
- Tomkins, G.S., Henderson, R.C., & Peterson, H.D. (1990), 'Bilateral simultaneous fractures of the femoral neck: case report', *Journal of Trauma*, vol. 30, pp. 1415 - 1416.
- Uman, M.A. (1969), 'Lightning', McGraw-Hill Book Company, USA, pp. 1-13.
- Uman, M.A. (1971), 'Comparison of lightning and a long laboratory spark', *Proceedings of the IEEE*, vol. 59, no 4, pp. 457 - 466.
- Uman, M.A., Cookson, A.H., & Mooreland, J.B. (1970), 'Shock wave from a four-metre spark', *Journal of Applied Physics*, vol. 41, no. 7, pp. 3148 - 3155.
- Ummenhofer Graber J.W., Herion, H. (1996), 'Lightning accident with eight victims: case report and brief review of the literature', *Journal of Trauma*, vol. 40, pp. 288-290.
- Van den Brink, W.A., van Leeuwen, O. (1995), 'Lumbar bursa fracture due to low voltage shock', *Acta Orthopaedica Scandinavica*, vol. 66, pp. 374 -375.
- Vershinin, Yu. N., (2002), 'Parameters of electronic detonation in solid dielectrics', *Technical Physics*, vol. 47, no. 12, 2002, pp. 1524–1528. Translated from *Zhurnal Tekhnicheskoi Fiziki*, vol. 72, no. 12, 2002, pp. 39–43, INTERNET.
<http://www.capturedlightning.com/Papers/8652386.pdf>. Cited 30 March 2014.
- Ward, S.R. Lieber, R.L. (2005), 'Density and hydration of fresh and fixed human skeletal muscle'. *Journal of Biomechanics*, vol. 38, no. 11, pp. 2317 - 2320.
- Weiss, K.S. (1980), 'Otologic lightning bolts', *American Journal of Otolaryngology*, August, vol. 1, no. 4, pp. 334 – 337.
- Wetli, C.V. (1996), 'Keraunopathology – An analysis of 45 fatalities', *The American Journal of Forensic Medicine and Pathology*, vol. 17, no. 2, pp. 89 – 98.
- Wightman, J.M., Gladish, S.L. (2001), 'Explosions and blast injuries'. *Annals of Emergency Medicine*, vol. 37, pp. 664 - 678.

- Wright, J.W. (1974), 'Acoustic and vestibular defects in lightning survivors', Presented at the meeting of the Middle Section of the American Laryngological, Rhinological and Otological Society, Inc. Kansas City, Mo., January 19 1974.
- Wright, R.K. & Tate, L.G. (1980), 'Forensic pathology, Last stronghold of the autopsy', *The American Journal of Forensic Medicine and Pathology*, vol. 1, no. 1, March, pp. 57 – 60.
- Wright, R.K., Gantner, G.E., (1990), 'Electrical injuries and lightning', Chapter 18. *Handbook of Forensic Pathology*. College of American Pathologists. Richard C Froede, Editor. ISBN 0-930304-39-X.
- Zack, F., Hammer, U. (1997), 'Myocardial injury due to lightning', *International Journal of Legal Medicine*, vol. 110. pp. 326 – 328.
- Zack, F., Rothschild, M.A., Wegener, R., (2007), 'Lightning strike-mechanisms of energy transfer, cause of death, types of injury.' *Deutsches Ärzteblatt*, vol. 104, P. A3545-9. pp. 51 – 52.
- Zipf, R.K. and Cashdollar, K.L. (2007), 'Explosions and Refuge Chambers, Effects of Blast Pressure on Structures and the Human Body'" NIOSH Docket Number 125. National Institute for Occupational Safety and Health, Columbus, OH. INTERNET.
<http://www.cdc.gov/niosh/docket/archive/pdfs/NIOSH-125/125-ExplosionsandRefugeChambers.pdf>. Cited 9th March 2014.

APPENDICES

APPENDIX A

Presentations surrounding and leading up to this thesis:

Lightning awareness documentary, 'Carte Blanche', February 2006.

Lightning awareness documentary, 'The Anonymous Killer', Peter Lamberti, Aquavision Productions, 2007-2008.

Lightning awareness documentary, 'Raging Planet 2', Discovery Channel, Pioneer Productions, Ian White, 2008.

Consultant to the South African Weather Service, Lightning awareness program, 2008.

Lectured on behalf of South African Weather Service, 24th Feb to 26th February 2009, SciFest Africa, Grahamstown, on the topic of 'Lightning CSI'.

National Geographic 2009, Tigress Productions, James Reed, Lightning deaths in Animals, May 27th 2009. Nature Shock, Tigress Productions, James Reed, 'Elephant Graveyard', Released UK 27 October 2009, Released USA 7 November 2009.

Podcast: The Naked Scientist Interview, INTERNET, 2012.
<http://www.thenakedscientists.com/HTML/podcasts/archive/africa/>
Cited 30 March 2014.

Honorary Rangers, Pretoria region, 'Lightning awareness lecture', 2007 - 2014.

Rotary club, Pretoria & Jhb regions, 'Lightning awareness lecture', 2007 - 2014.

'Lightning and electrothermal injury' lecture series to medical students University of Pretoria, as requested yearly 2008 - 2014.

'Lightning and electrothermal injury' lecture series to medical students at the University of Limpopo, Medunsa campus, yearly from 2009 - 2014.

Hiking and birding clubs South Africa, invited speaker, 'lightning awareness lecture', Pretoria and Johannesburg clubs, 2007 - 2014.

Tuesday Forum, Lecture at the Aula, University of Pretoria, 'When Thunder Roars - Go Indoors!' contact person Elsje Myburgh, 2nd August 2011.

2011 ECSSA Pre-Hospital Emergency Care Congress, University of JhB, Lightning lecture for emergency care professionals, 22 September 2011.

South African Police Service lecture series, Pretoria, Serious and Violent Crime Unit and Psychologically-Motivated Crime Unit, 23rd February 2012, 08h00-09h00, 2nd July 2013 09h00-10h00 and again 15th January 2015 12h00-1400.

LIGHTS (Lightning Interest Group Health Technology and Science) invited speaker 7th March 2012 & 12th September 2013, University of the Witwatersrand.

'The Complexities of Lightning', *Wattnow Journal*, April 2012, pp. 37.

'Weather Guilty or Not', The weather channel, DSTV channel 415, 20th March 2014. INTERNET. <http://www.youtube.com/watch?v=MTkjlUwdXeo&list=PLxJ8ks5VMybCzbxHc9HVaq4oPs4jtl-S6&feature=share&index=3> Cited 2nd September 2014.

'Is lightning's 'blast' as bad as its strike?' Mail & Guardian, Cited: 22nd August 2014. INTERNET. <http://mg.co.za/article/2014-08-15-is-lightnings-blast-as-bad-as-its-strike> Cited 2nd September 2014.

'Strange Friction', *Sunday Times*, 30th November 2014. pp 18 – 19.

APPENDIX B

Peer-reviewed publications surrounding and leading up to this thesis:

Blumenthal, R., (2005), 'Lightning fatalities on the South African Highveld – A retrospective descriptive study 1997 – 2000', *The American Journal of Forensic Medicine and Pathology*, vol. 26, no. 1, pp. 66 – 69.

Blumenthal, R., (2006), 'When thunder roars – go indoors! Lightning autopsy guidelines', *South African Medical Journal*. January 2006, vol. 96, no. 1, pp. 38 – 39.

Blumenthal R., (2012), 'Secondary missile injury from lightning strike', *The American Journal of Forensic Medicine and Pathology*, vol. 33, no. 1, March, pp. 83 - 85.

Blumenthal, R., Jandrell, I.R., West, N.J., (2012), 'Does a sixth mechanism exist to explain lightning injuries? Investigating a possible new injury mechanism to determine the cause of injuries related to close lightning flashes', *The American Journal of Forensic Medicine and Pathology*, vol. 33, no. 3, September 2012, pp. 222 - 226.

Blumenthal, R., Jandrell, I.R., Trengrove, E., & Saayman, G. (2012), 'Lightning medicine in South Africa', *South African Medical Journal*. July 2012, vol. 102, no. 7, pp. 625 - 626.

Blumenthal, R. (2014), 'Lightning medicine in rural practice', *Journal of Neurosciences in Rural Practice*, Editorial, October – December, vol. 5, no. 4, pp. 325.

Blumenthal, R., West, N.J. (2014b), 'Investigating the Risk of Lightning's Pressure Blast Wave', *South African Journal of Science*, Accepted for publication 9th August 2014.

APPENDIX C

Book chapters surrounding and leading up to this thesis:

Fish, R.M. & Geddes, L.A., (2008), 'Electrical Injuries. Medical and Bioengineering Aspects', Second Edition, Lawyers & Judges Publishing Company, Inc. Tucson, AZ 85751-0040. First published 2003. ISBN: 978-1-933264-63-9, Chapter 43, Forensic Perspectives in Electrical Fatality Cases, pp. 509 – 511.

Auerbach, P.S., (2012), 'Wilderness Medicine', Sixth Edition, Elsevier Mosby. 1600 John F Kennedy Blvd. Ste 1800. Philadelphia, PA 19103-2899. First published 1983. ISBN: 978-1-4377-1678-8. Chapter 3: Lightning Injuries. Mary Ann Cooper, Ronald Holle, Christopher Andrews and Ryan Blumenthal. pp. 60 – 101.

Madea, B.M. (2014), 'Handbook of Forensic Medicine', ISBN: 978-0-470-97999-0, Wiley-Blackwell Publishers, The Atrium, Southern Gate, Chichester, West Sussex, PO198SQ, UK, Chapter 24: Electrocution and Lightning, Ryan Blumenthal, pp. 477 – 494.

APPENDIX D

Congress presentations surrounding and leading up to this thesis:

Blumenthal, R., (2003), 'Lightning Fatalities on the South African Highveld – A Retrospective Descriptive Study 1997 – 2000', Oral presentation, *International Congress on Lightning and Static Electricity (ICOLSE)*, Blackpool UK.

Blumenthal, R., (2007), 'A Retrospective Descriptive Study on the Pathology of Trauma of Lightning Fatality Cases in Gauteng 2001 – 2004', Oral presentation, *International Congress on Lightning and Static Electricity (ICOLSE)*, France, Paris.

Jandrell, I.R., Blumenthal, R., Anderson, R.B., Trengrove, E. (2009), 'Recent Lightning Research in South Africa with a special focus on Keraunopathology', *ISH2009: Final Programme - Paper K-1*. Monday 24th August 2009, Cape Town Convention Centre, Assisted with the paper, however did not attend the congress.

International Blast and Ballistic Congress (2006), CSIR, Pretoria, 25th to 28th September 2006, Attended the congress.

Blumenthal, R., (2012), 'The forensic investigation of fatal lightning strike victims - Reconsidered and revised', *International Conference on Lightning Protection*. Vienna, Austria 2-7 September 2012, Conference Proceedings.

Grant, M.D., Tordiffe, S.W., & Blumenthal, R., (2012), 'Case study of lightning-caused death of critically endangered *Tragelaphus Sp.*', *International Conference on Lightning Protection*, Vienna, Austria 2-7 September 2012, Conference Proceedings.

Lightning Interest Group for Health Technology and Science (LIGHTS), Day congress, 8th March 2012 (key-note speaker), WITS Professional Development Hub.

Lightning Interest Group for Health Technology and Science (LIGHTS). Day congress 12th September 2013 presented a paper entitled 'updates in keraunopathology', WITS Professional Development Hub.

APPENDIX E

This appendix provides independent testing results of the 2012 sixth mechanism experiment, by Nhlakanipho Jiyane and Hugh Hunt.

Experiments with Nichrome wire:

Laboratory Test Results, taken on the 19 November 2011, at Wits University.

Table 7.1: Table documenting incremental fissure/fracture cracks in soft gelatine. As the current increased through the wire, the size of the temporary cavity also increased in a directly proportional manner.

Test Current(kA)	Test Voltage(kV)	Diameter(X mm)	Diameter(Y mm)
1.50	0.50	Nothing happened to the gel.	Nothing happened to the gel.
3.00	1.00	Nothing happened to the gel.	Nothing happened to the gel.
4.50	1.50	20.17	13.82
6.00	2.00	76.44	89.65
7.50	2.50	81.68	115.48
9.00	3.00	25.41	45.54
10.50	3.50	Was unable to take a reading.	21.50

Table 7.2: Graph demonstrating incremental fissure/fracture cracks in Corbin's gel. As the current increased through the wire, the size of the temporary cavity also increased in a directly proportional manner

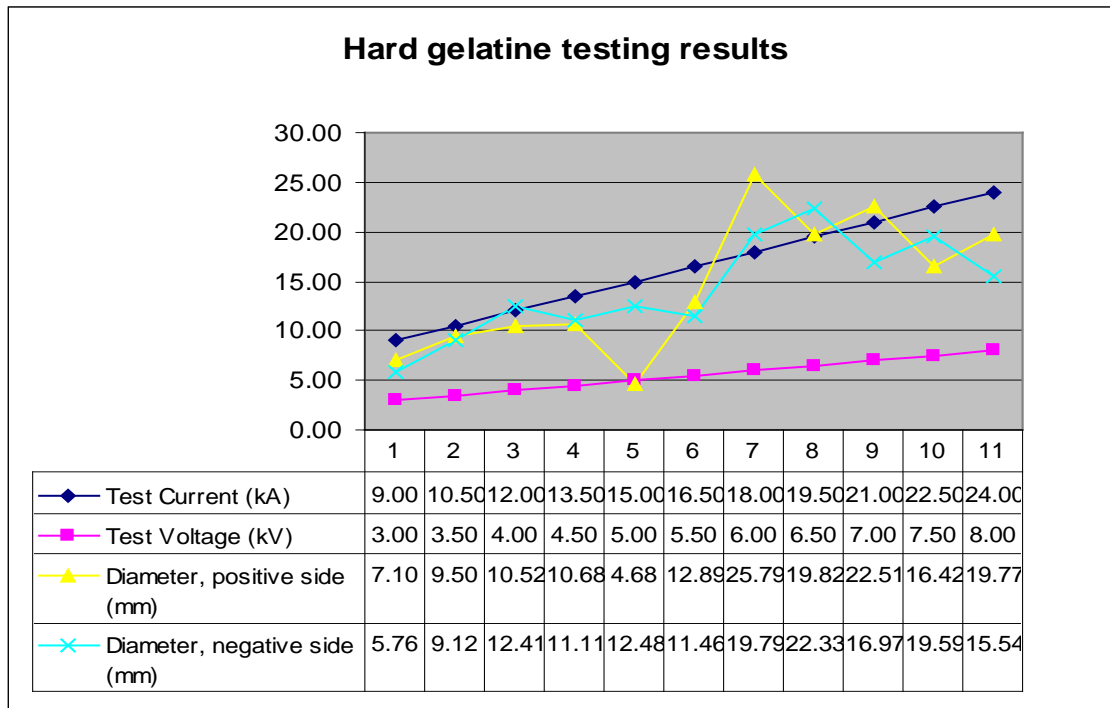

APPENDIX F

This appendix provides independent testing results of the 2012 sixth mechanism experiment, by NJ West.

Laboratory Test Results, taken on the 1st August 2012, at Wits University.

Experiments with Nichrome wire: *Wire with a resistance of 14.39 ohms/m, length of 250 mm, 0.213 mm diameter.

Table 7.3: Graph demonstrating incremental fissure/fracture cracks in Corbin's gel. As the current increased through the wire, the size of the temporary cavity also increased in a directly proportional manner

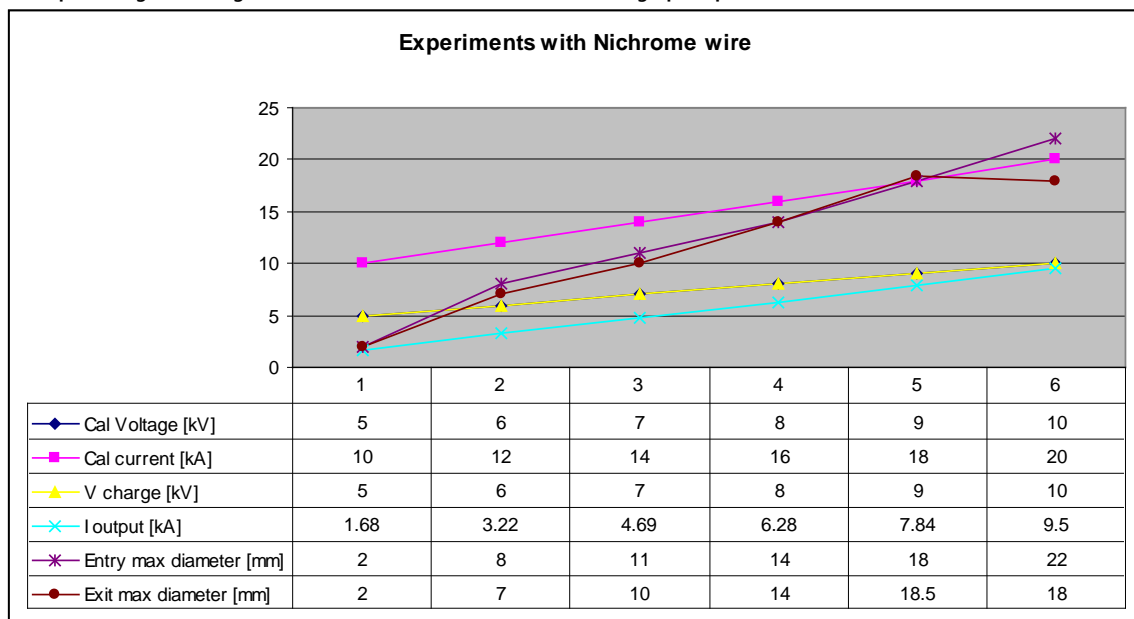

APPENDIX G

This appendix provides results of experiments at WITS High-Voltage Laboratory 10th March 2014 by N J West and R Blumenthal. Sixth mechanism paper experiments 2014.

(Spark gap = 5mm).

Table 7.4: Graph demonstrating incremental fissure/fracture cracks in dry, distilled-water and saline soaked paper.

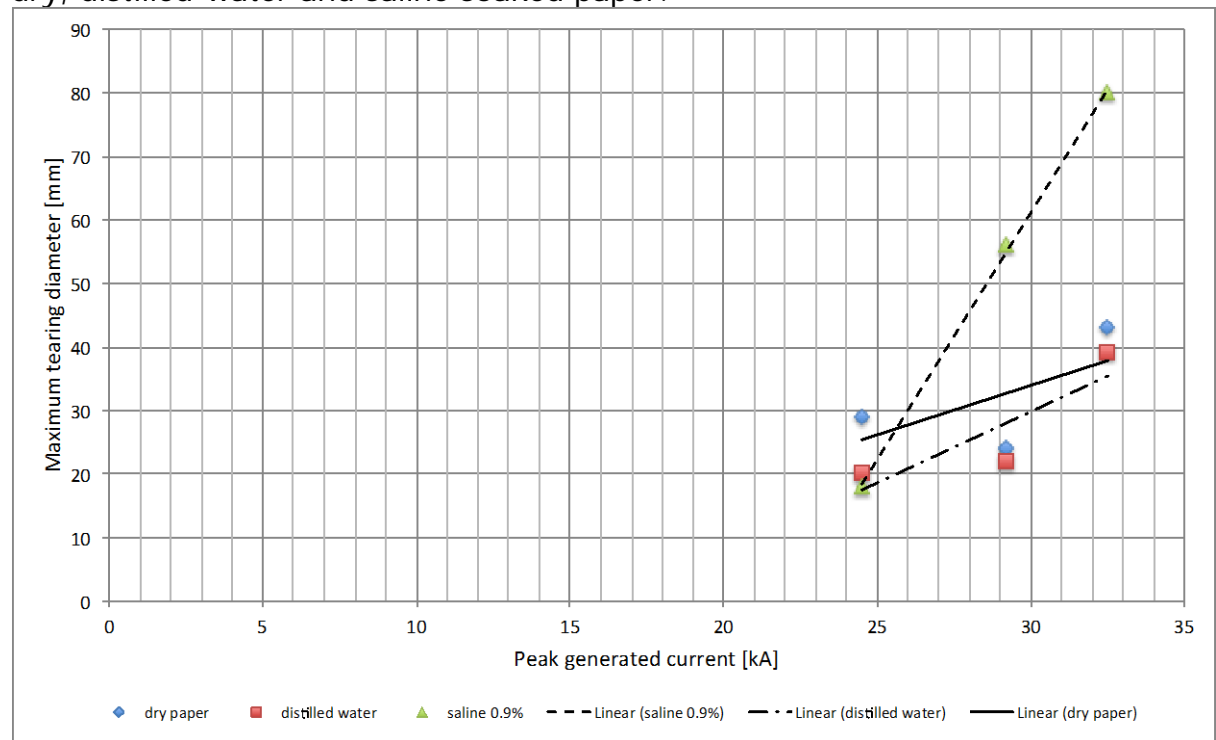

APPENDIX H

Table 7.5: Damage approximations of explosive shocks in air.

Damage approximations	
Damage	Incident Overpressure
Typical window glass breakage	0.15 – 0.22 psi (1.03 – 1.51 kPa)
Minor damage to some buildings	0.5 – 1.1 psi (3.44 – 7.58 kPa)
Panels of sheet metal buckled	1.1 – 1.8 psi (7.58 – 12.40 kPa)
Failure of concrete block walls	1.8 – 2.9 psi (12.4 – 19.99 kPa)
Collapse of wood framed buildings	Over 5.0 psi (Over 34.47 kPa)
Serious damage to steel framed buildings	4 – 7 psi (27.58 – 48.26 kPa)
Severe damage to reinforced concrete structures	6 – 9 psi (41.37 – 62.05 kPa)
Probable total destruction of most buildings	10 – 12 psi (68.94 – 82.73 kPa)

Sources: The Effects of Nuclear Weapons, 3rd Edition, Glasstone & Dolan, 1977. Explosive Shocks in Air, Kinney & Graham, 1985.

APPENDIX I

Table 7.6: High explosive overpressure constants and consequences.

High Explosive Overpressure Constants and Consequences	
<u>Overpressure</u>	<u>Consequences</u>
0.01 – 0.04 psi (0.06 – 0.27 kPa)	Minimum damage to glass panels
0.1 – 0.2 psi (0.68 – 1.37 kPa)	Typical window glass breakage
0.2 – 0.4 psi (1.37 – 2.75 kPa)	Minimum overpressure for debris and missile damage
0.5 – 1.1 psi (3.44 – 7.58 kPa)	Windows shattered, plaster cracked, minor damage
1.0 – 1.5 psi (6.89 – 10.34 kPa)	Personnel knocked down
1.0 – 1.8 psi (6.89 – 12.41 kPa)	Panels of sheet metal buckled
1.0 – 2.0 psi (6.89 – 15.6 kPa)	Failure of wooden siding for conventional homes
1.8 – 2.9 psi (12.41 – 19.99 kPa)	Failure of walls constructed of concrete blocks
2.9 – 4.4 psi (19.99 – 30.33 kPa)	Self-framing panelled buildings collapse
2.9 – 4.4 psi (19.99 – 30.33 kPa)	Oil storage tanks ruptured
4.4 – 7.3 psi (30.33 – 50.33 kPa)	Utility poles broken off
4.4 – 7.3 psi (30.33 – 50.33 kPa)	Serious damage to buildings with structural steel framework
10.2 – 11.6 psi (70.32 – 79.97 kPa)	Probable total destruction of most buildings
5.1 – 14.5 psi (35 – 100 kPa)	Eardrum rupture
5.8 – 8.7 psi (39.98 – 59.98 kPa)	Reinforced concrete structures severely damaged
5.8 – 8.7 psi (39.98 – 59.98 kPa)	Railroad cars overturned
29.0 – 72.5 psi (200 – 500 kPa)	Lung damage
102 – 218 psi (703.25 – 1503.04 kPa)	Lethality
290 – 435 psi (1999.46 – 2999.19 kPa)	Crater formation in average soil

Source: Kinney and Graham, 1985

APPENDIX J

Table 7.7: Direct blast effect of explosions: Fatalities and injuries.

Direct blast effect of explosions: Fatalities and Injuries	
(Effective overpressure in psi and kPa. Overpressure duration more than 100 milliseconds)	
<u>Eardrum rupture</u>	
Threshold	5 psi (34kPa)
50-percent (20 or more years old)	15-20 psi (103 to 137kPa)
(less than 20 years old)	30-35 psi (206 to 241kPa)
<u>Lung Damage</u>	
Threshold	12 psi (range 8-15psi) 82kPa (55 to 103kPa)
Severe	25 psi (range 20-37psi) 172kPa (137 to 155kPa)
<u>Lethal</u>	
Threshold	40 psi (range 30-50psi) 275kPa (206 to 344kPa)
50-percent	62 psi (range 50-75psi) 427kPa (344 to 517kPa)
100-percent	92 psi (range 75 – 115psi) 620kPa (517 to 742kPa)
Source: “Effects of Nuclear Weapons” Atomic Energy Commission U.S. Department of Defence, Government Printing Office, Washington D.C., 1977	

APPENDIX K

Table 7.8: Human injury in proximity to a small bomb.

Human Injury in Proximity to a Small Bomb	
(Bomb 4,5kg (TNT equivalent). Individual's weight 72kg. Open air)	
Hearing:	
Temporary loss	330,3 feet (100m)
Eardrum rupture threshold	31,1 feet (9,45m)
100-percent eardrum rupture	2,5 feet (3,66m)
Lung damage:	
Collapse threshold	19,4 feet (3,6m)
100-percent lethality	6,7 feet (1,83m)
Body:	
Injury threshold	12,5 feet (3,6m)
Lethality threshold	10,0 feet (3,05 m)
100-percent lethality	6,1 feet (1,83m)
Source: "Effects of Nuclear Weapons" Atomic Energy Commission U.S. Department of Defence, Government Printing Office, Washington D.C., 1977	