

Seal

Court File No. T -1926 - 15

FEDERAL COURT

BETWEEN:

CANADIAN TIRE CORPORATION, LIMITED

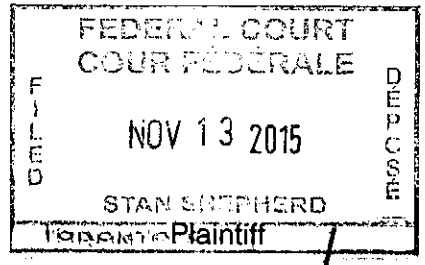

- and -

WAL-MART CANADA CORP.,
TOMSON MERCHANDISE CO. LTD., AND
EVERSTAR MERCHANDISE CO. LTD.

Defendants

STATEMENT OF CLAIM

TO THE DEFENDANTS:

A LEGAL PROCEEDING HAS BEEN COMMENCED AGAINST YOU by the Plaintiff. The claim made against you is set out in the following pages.

IF YOU WISH TO DEFEND THIS PROCEEDING, you or a solicitor acting for you are required to prepare a statement of defence in Form 171B prescribed by the *Federal Court Rules*, serve it on the plaintiff's solicitor or, where the plaintiff does not have a solicitor, serve it on the plaintiff, and file it, with proof of service, at a local office of this Court, WITHIN 30 DAYS after this statement of claim is served on you, if you are served in Canada.

If you are served in the United States of America, the period for serving and filing your statement of defence is forty days. If you are served outside Canada and the United States of America, the period for serving and filing your statement of defence is sixty days.

Copies of the *Federal Court Rules*, information concerning the local offices of the Court and other necessary information may be obtained on request to the Administrator of this Court at Ottawa (telephone 613-992-4238) or at any local office.

IF YOU FAIL TO DEFEND THIS PROCEEDING, judgment may be given against you in your absence and without further notice to you.

**STAN SHEPHERD
SENIOR REGISTRY OFFICER
AGENT PRINCIPAL DU GREFFE**

Dated: November 13, 2015

Issued by: _____
(Registry Officer)

Address of 180 Queen Street West
Local Office: 2nd Floor
Toronto, Ontario
M5V 3L6

TO: **WAL-MART CANADA CORP.**
1940 Argentia Rd.
Mississauga, ON
L5N 1P9

AND TO: **TOMSON MERCHANDISE CO. LTD.**
7F.NO.285.SEC 4.CHUNG HSIAO E Road
Taipei, Taiwan
Republic of China

AND TO: **EVERSTAR MERCHANDISE CO. LTD.**
7F.NO.285.SEC 4.CHUNG HSIAO E Road
Taipei, Taiwan
Republic of China

CLAIM

1. The Plaintiff claims:
 - (a) a declaration that the Defendants, jointly or severally, and directly or indirectly by inducing or procuring the same, have:
 - (i) infringed and induced infringement of Canadian Industrial Design Reg. No. 158920 (the "Industrial Design") owned by the Plaintiff, by their respective or collective making, importing, selling, and offering for sale of infringing light socket and clip products to which the Industrial Design or a design not differing substantially therefrom has been applied, contrary to s. 11 of the *Industrial Design Act*, RSC 1985, c I-9.
 - (ii) directed public attention to their goods, services or business in such a way as to cause or be likely to cause confusion in Canada, at the time they commenced so to direct public attention to them, between their goods, services or business and the goods, services or business of the Plaintiff, contrary to s. 7(b) of the *Trade-marks Act*, RSC 1985, c T-13, including without limitation by adopting, using, and promoting the Plaintiff's distinctive trade-marks and trade indicia as described herein (the "Quick-Clip Lights Trade-marks and Trade Dress") and by using unauthorized photographic images of Plaintiff's own product, in association with the Defendants' unauthorized light socket and clip products and packaging.

- (iii) for the purpose of promoting, directly or indirectly, the supply or use of a product or for the purpose of promoting, directly or indirectly, any business interest, by any means whatever, knowingly or recklessly made representations to the public that are false and misleading in a material respect contrary to s. 52 of the *Competition Act*, RSC 1985, c C-34.

- (b) an interim, interlocutory and permanent injunction restraining the Defendants, along with any parents, affiliates, subsidiaries and all other related companies and businesses and their respective and collective officers, directors, employees, agents, partners, licensees, franchisees, successors and assigns, as well as all others over whom any of the foregoing exercise control or authority from:
 - (i) using photographs of Plaintiff's own Quick-Clip Lights on Defendants' packaging or otherwise to promote the sale of Defendants' products;
 - (ii) purchasing, ordering, selling, offering for sale, making or having made, or importing light socket and clip products to which the Industrial Design or a design not differing substantially therefrom has been applied.
 - (iii) directing public attention to their goods, services or business in such a way as to cause or be likely to cause confusion in Canada, at the time they commenced so to direct public attention to them, between their goods, services or business and the goods, services or business of the Plaintiff, contrary to s. 7(b) of the *Trade-marks*

Act, including without limitation by adopting, using, or promoting in Canada or to Canadians the Plaintiff's Quick-Clip Lights Trade-marks and Trade Dress as or as part of any trade-mark, trade name, business name, corporate name, trading style, metatag (or other Internet search engine optimization tool or device), social media account name, or domain name, associated directly or indirectly with light socket and clip products.

- (iv) for the purpose of promoting, directly or indirectly, the supply or use of a product or for the purpose of promoting, directly or indirectly, any business interest, by any means whatever, knowingly or recklessly making representations to the public that are false and misleading in a material respect.
- (c) an interlocutory and final Order requiring these same parties to deliver-up or destroy under oath any infringing articles in their power, possession, or control that are or that would be contrary to any Order granted by this Court, in accordance with s. 15.1 of the *Industrial Design Act*,
- (d) an interlocutory and final Order requiring these same parties to deliver-up or destroy under oath any goods, packaging, labels, and advertising materials (and any equipment used to produce the same) in their possession, power or control that are or that would be contrary to any Order granted by this Court, in accordance with s. 53.2 of the *Trade-marks Act*,
- (e) damages or an accounting of the Defendants' profits from their infringements of the Industrial Design and their passing-off as described

above and herein, at the Plaintiff's election at any time before final judgment is rendered;

- (f) an amount equal to the loss or damages suffered by the Plaintiff as a result of the Defendants' violations of the *Competition Act*, and the Plaintiff's costs of the investigation in connection with this matter and proceedings, in accordance with s. 36(1) of the *Competition Act*;
- (g) punitive damages in the amount of \$500,000;
- (h) pre-judgment and post-judgment interest in accordance with the *Federal Courts Act*;
- (i) costs of this action on the highest available scale; and
- (j) such further relief as the Court may deem just.

The Plaintiff and its Rights

2. The Plaintiff, Canadian Tire Corporation, Limited, is a corporation organized under the laws of the Province of Ontario, with a registered business address or principal place of business at 2180 Yonge Street, P.O Box 770, Station K, Toronto, ON, M4P 2V8.
3. Founded in Toronto in 1922, the Plaintiff is one of Canada's most recognized and trusted retailers, with over 1,700 locations across Canada. To this day the Plaintiff is a leading Canadian retailer for, among other things, housewares, sports and recreation, automotive, and home decor products.

4. The Plaintiff has been a source of product innovation in Canada since 1922. The company has invested millions of dollars in designing and developing its private label brands. Through Canadian-led innovation, including extensive research and design, the Plaintiff has developed and sold in Canada a line of holiday lights and related accessories. Each of the Plaintiff's decorative holiday lights and accessory products is packaged and advertised with a variety of distinctive trade-marks and other trade indicia.
5. In 2013, the Plaintiff developed a unique light socket and clip system for securing and displaying holiday lights on buildings and residential properties. Featuring an innovative and distinctive design, the Plaintiff's products are a combination of a light socket and a spring-operated clip mechanism which can be used to mount, secure and display a string of holiday lights to, among other things, eaves, shingles, trees, bushes, and railings. The clip portion of the product swivels relative to the socket portion to allow the user to easily adjust the light position when mounted.
6. The Plaintiff took all necessary steps to protect its innovative socket and light system, and has made the appropriate filings for all associated intellectual property, including industrial designs, design patents and trademarks, as fully set out below. The Plaintiff took these steps to prevent competitors from misappropriating the Plaintiff's intellectual property and to prevent the deception of Canadian consumers through the type of misconduct practiced by the Defendants, which is particularized in paragraphs 19 -39 below.
7. The Plaintiff's Quick-Clip Lights are of solid construction and certified by the Canadian Standards Association. The Plaintiff stands behind the workmanship of

its products by offering Canadian consumers a 5 year limited warranty against defects in workmanship and materials.

8. The Plaintiff is the owner of the Industrial Design, which was registered in Canada on July 28, 2015, and which comprises a design in and to its innovative light socket and clip product.

9. The Industrial Design comprises the features of shape, configuration, pattern and ornament, and combination of those features that, in the Plaintiff's light socket and clip product, appeal to the eye of the consumer. Registration particulars of the Industrial Design are attached as Schedule "A" hereto, and a representative image of the Industrial Design is shown below:

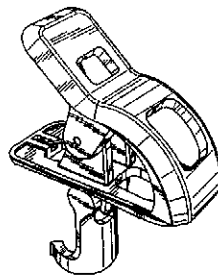

FIG. 1

10. Pursuant to the *Industrial Design Act*, by virtue of the Industrial Design, the Plaintiff enjoys the exclusive right for ten years to make, import for the purpose of trade or business, sell, rent, offer, expose for sale or rent, any article in respect of which the Industrial Design or a design not differing substantially therefrom has been applied.

11. The Plaintiff's products are packaged and advertised in association with the distinctive Quick-Clip Lights Trade-marks and Trade Dress which comprise at least the following elements:

- (a) a uniquely shaped, green-coloured light socket and clip, featuring a pair of spring-operated arms with distinctive cut-out portions on each arm.
- (b) packaging in which these light socket and clip products are prominently displayed against a black background, in combination with diamond or “pinecone” patterned light bulbs.
- (c) the word mark QUICK-CLIP, which is the subject matter of Canadian Trademark Application 1,752,668.

12. By way of illustrative examples, the Quick-Clip Lights Trade-marks and Trade Dress can be seen in association with the Plaintiff’s products below and at Schedule “B” hereto:

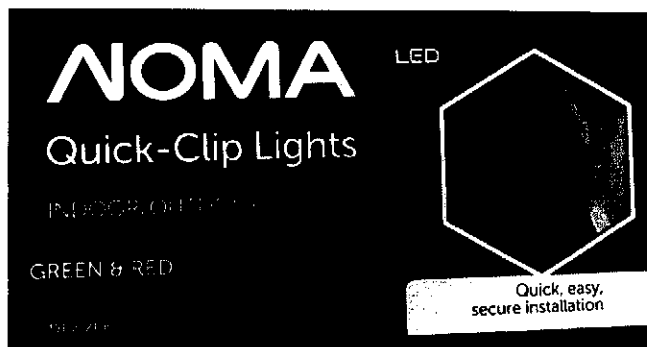

- 13. The combination of elements of the Quick-Clip Lights Trade-marks and Trade Dress form a recognizable and distinctive brand of the Plaintiff.
- 14. The Plaintiff is the owner in Canada of the Quick-Clip Lights Trade-marks and Trade Dress.
- 15. The Plaintiff was the first retailer to introduce a light socket and clip product of the type embodied by its Quick-Clip Lights products to the Canadian marketplace.

16. Since their introduction, the Plaintiff has enjoyed significant success with its QUICK-CLIP holiday light socket and clip products, particularly during the Christmas and holiday periods in both 2013 and 2014. During that time and to the present, the Plaintiff has sold, offered for sale, advertised and extensively promoted its Quick-Clip Lights in Canada. In that time, the Quick-Clip Lights Trade-marks and Trade Dress have been prominently featured in both online and print advertising.
17. As a result of the Plaintiff's significant sales and extensive marketing activities, the Plaintiff has developed substantial goodwill and reputation in and to the Quick-Clip Lights Trade-marks and Trade Dress in Canada.
18. The Plaintiff has never authorized the Defendants to use any of its intellectual property rights described herein in any manner in Canada or elsewhere.

The Defendant and its Unauthorized Activities

19. The Defendant, Wal-mart Canada Corp. ("Wal-mart") is the Canadian division of the U.S. retailer Wal-mart, and is a corporation incorporated under the law of Ontario with a registered business address or principal place of business located at 1940 Argentia Rd., Mississauga, ON, L5N 1P9. Wal-mart is a competitor of the Plaintiff in Canada.
20. The Defendant, Tomson Merchandise Co. Ltd. ("Tomson"), is a corporation incorporated under the laws of the Republic of China, with a registered business address or principal place of business located at 7F.NO.285.SEC 4.CHUNG

HSIAO E Road, Taipei, Taiwan, R.O.C. Tomson is believed to be a manufacturer, supplier, distributor, and/or exporter of various consumer goods.

21. The Defendant, Everstar Merchandise Co. Ltd. ("Everstar"), is a corporation incorporated under the laws of the Republic of China, with a registered business address or principal place of business located at 7F.NO.285.SEC 4.CHUNG HSIAO E Road, Taipei, Taiwan, R.O.C. Everstar is believed to be a manufacturer, supplier, distributor, and/or exporter of various consumer goods.
22. From a time unknown to the Plaintiff, and without any license or permission, the Defendants have manufactured, imported into Canada, distributed, offered for sale, sold, advertised, and promoted infringing holiday light socket and clip products through Wal-mart's chain of Walmart retail stores in Canada.
23. Representative images of the Defendants' infringing products and packaging are shown below and attached as Schedule "C":

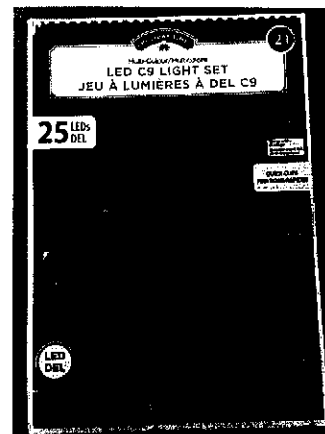

24. The design of the Defendants' light socket and clip products does not differ substantially from the design registered in the Industrial Design:

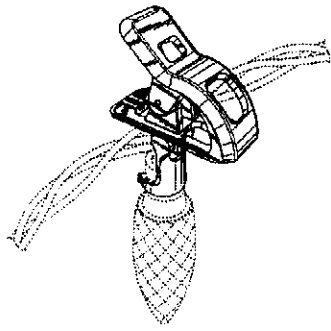

FIG. 1

Design No. 158,920

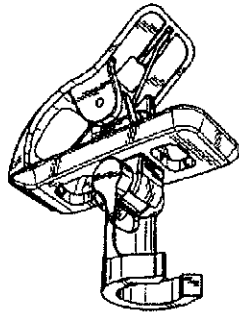
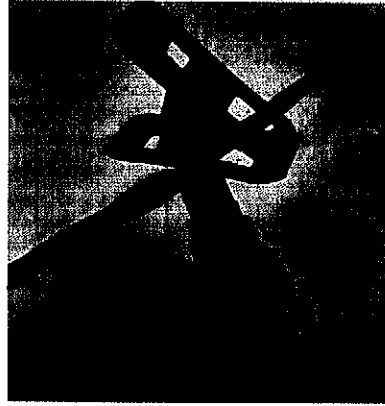

FIG. 2

Design No. 158,920

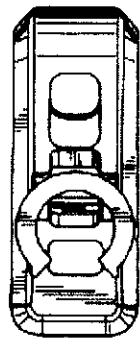
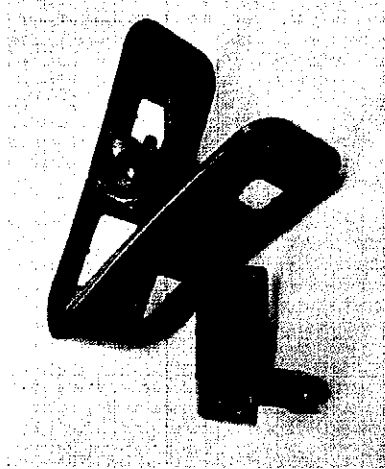
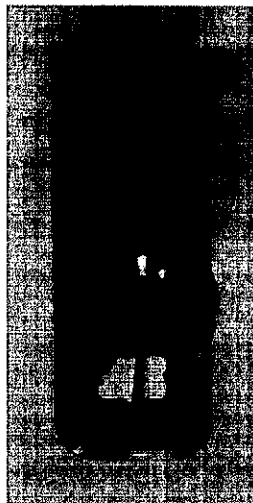

FIG. 3

Design No. 158,920



25. The Defendants' products are also advertised, packaged, and sold in association with trade-mark and trade indicia which are identical or highly similar to the Plaintiff's distinctive Quick-Clip Lights Trade-marks and Trade Dress described above, comprising, among other things:
 - (a) packaging displaying a uniquely shaped, green-coloured light clip and socket featuring a pair of spring-operated arms with cut-out portions on each arm, which is actually a photograph of the Plaintiff's light clip and socket product, not the Defendants' product.
 - (b) packaging which features a prominent front panel with a black background and coloured lights in a pinecone shape;
 - (c) the word mark "QUICK CLIPS".
26. There is therefore a very strong overall visual similarity and identity between the packaging and products displayed on the exterior of the Defendants' Quick Clips packaging and the Plaintiff's Quick-Clip Lights Trade-marks and Trade Dress.
27. The Defendants' unauthorized trade-marks and trade dress as described herein are therefore confusing with the Plaintiff's Quick-Clip Lights Trade-marks and Trade Dress and are likely to deceive Canadian consumers as to the source or origin of the associated products.
28. The Defendants have acted opportunistically and attempted to capitalize on the significant goodwill and reputation in and to the Plaintiff's successful Quick-Clip Lights Trade-marks and Indicia. With their Quick Clips product, the Defendants are attempting to trade on the reputation of the Plaintiff's Quick-Clip Lights Trade-marks and Trade Dress and obtain instant public recognition for their own

products, based on the association between their unauthorized trade-marks and indicia appearing on packaging for the Quick Clips products and the trade-marks and indicia of the Plaintiff.

29. In so doing, the Defendants are trying to obtain a marketing “free ride” to create instant demand for and sales of their products, while avoiding product design and advertising costs that they would otherwise need to expend if they were attempting to legitimately create such public awareness and reputation in their own brand and products.
30. Moreover, the product actually sold to consumers in the Defendants’ Quick Clips packaging is not the product shown on the exterior of that packaging. The light socket and clip product actually found inside the Defendants’ packaging is made of lightweight plastic and is produced by inferior workmanship.
31. Without any authorization or colour of right, the Defendants have created packaging designed to deceive consumers into thinking they are purchasing the Plaintiff’s Quick-Clip Lights. The Defendants’ misleading packaging actually displays a photograph of Plaintiff’s products (not the Defendants’ products) on the principal panel of the box:

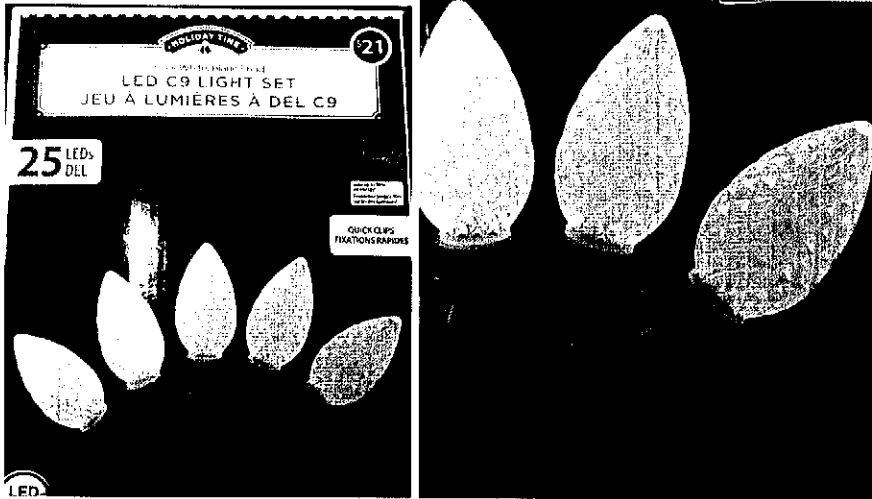

("Bait & Switch Photograph")

32. Defendants' blatantly deceptive packaging is false and misleading in that it creates the impression for consumers that the package actually contains the Quick-Clip Lights illustrated on its principal front panel. Defendant's package is constructed of cardboard so consumers necessarily rely upon, and are motivated to make their purchase decision by, the Bait & Switch Photograph on the box, which in fact does not correspond to Defendant's lights but reproduces the Plaintiff's product.

33. For these reasons, consumers who purchase the Defendants' Quick Clips are likely to believe they are buying the Plaintiff's Quick-Clip Lights, but will instead receive the Defendants' inferior, lightweight copy. In this manner, the Defendants have knowingly promoted their products to the public through representations that are false or misleading in a material respect. Defendants' packaging constitutes a bait and switch which is calculated to deceive consumers into purchasing an inferior substitute.
34. The precise relationships between the Defendants, and their respective individual or collective roles in manufacturing, importing into Canada, distributing, offering for sale, selling, advertising, and promoting their infringing Quick Clips light socket and clip products are not known to the Plaintiff but are known to the Defendants.
35. At all material times the Defendants have known or ought to have known about the Plaintiff, the registration for the Industrial Design, and the Quick-Clip Lights Trade-marks and Trade Dress, and that they were without authorization to make, import, sell, or offer for sale light socket and clip products to which the Industrial Design or a design not differing substantially therefrom was applied, or otherwise in association with the Bait & Switch Photograph, the Quick-Clip Lights Trade-marks and Trade Dress or marks or indicia confusingly similar thereto.
36. Given that the Plaintiff and the Defendant Wal-mart are direct competitors in Canada, and given that the Plaintiff has enjoyed significant success with its Quick-Clip Lights in the Canadian market, it is inconceivable that the Defendants could have copied the Industrial Design and adopted and used the Quick-Clip Lights Trade-marks and Trade Dress, and used the Bait & Switch Photograph of Plaintiff's own products in association with the manufacture, importation, sale, and

advertising of their "Holiday Time Quick Clips" without clear prior knowledge of the Plaintiff's intellectual property rights.

37. By all such activities the Defendants have:
- (a) infringed or induced the infringement of the Plaintiff's exclusive rights in its Industrial Design, contrary to s. 11 of the *Industrial Design Act*.
 - (b) directed public attention to their goods, services or business in such a way as to cause or be likely to cause confusion in Canada, at the time they commenced so to direct public attention to them, between their goods, services, or business and the goods, services, or business of the Plaintiff, contrary to s. 7(b) of the *Trade-marks Act*.
 - (c) passed off their goods as and for those of the Plaintiff, contrary to s.7(c) of the *Trade-marks Act*.
 - (d) made representations that are false or misleading in a material respect for the purpose of promoting, directly or indirectly, the supply or use of a product or business interest contrary to s. 52 of the *Competition Act*.
38. The Plaintiff has demanded that the Defendants cease their complained-of activities, but they refuse to do so. The Defendants therefore threaten to continue their unauthorized activities as described herein unless enjoined by the Court.
39. The Defendants' actions as described herein have caused the Plaintiff damage, including irreparable damage, and have and will enable the Defendants to enjoy unjust profits.

40. The full scope of the Defendants' activities in association with their infringing Quick Clips light socket and clip products are not known to the Plaintiff but are known to the Defendants and the Plaintiff claims fully in respect of same.
41. The Defendants' conduct constitutes a wilful, high-handed, and deliberate infringement of the Plaintiff's valuable intellectual property rights, and should attract the Court's condemnation with a substantial award of punitive damages.

Location of Trial and Nature of Proceeding

42. The Plaintiff proposes that this action be tried at Toronto, Ontario.
43. This action is not being pursued as a simplified proceeding.

November 13, 2015



GOWLING LAFLEUR HENDERSON LLP
1 First Canadian Place
100 King Street West, Suite 1600
Toronto, Ontario M5X 1G5

Christopher J. Pibus
Kevin Sartorio
James Green

Tel: (416) 862.5737
Tel: (416) 862.4492
Tel: (416) 369.7102
Fax: (416) 862.7661

Solicitors for the Plaintiff

Schedule "A" – Canadian Industrial Design Reg. No. 158920



Canadian Intellectual
Property Office
An Agency of
Industry Canada

Office de la propriété
intellectuelle du Canada
Un organisme
d'Industrie Canada

Canada

Canadian Intellectual Property Office

Registration number: 158920

Third-Party Information Liability Disclaimer

Date of Registration:
Status:

2015-07-28
Registered

Description of searchable fields:

Title: CLIP FOR LIGHT SOCKET

Canadian Classification:
003-05-05-02-Clips and Clamps
004-04-05-Parts for Lighting Fixtures

Other Classes Searched:
N/A



Description:

The design consists of the features of shape, ornament, pattern and configuration of the entire clip for light socket shown in the attached drawings. The portions shown in stippled lines in Figure 9 represent environment only and form no part of the design.

Figures 1, 2, 3, 4, 5, 6, 7, 8 and 9 show the claimed design; namely:

Figure 1 is a top and front facing, right perspective view of the claimed design;

Figure 2 is a bottom and rear facing, left perspective view of the claimed design;

Figure 3 is a side elevational view of the claimed design;

Figure 4 is a front elevational view of the claimed design;

Figure 5 is an opposing side elevational view of the claimed design;

Figure 6 is a rear elevational view of the claimed design;

Figure 7 is a top plan view of the claimed design;

Figure 8 is a bottom plan view of the claimed design; and

Figure 9 is a further top and front facing, right perspective view of the claimed design.

As noted above, drawings of the design numbered Figures 1 to and including 9 are included.

Interested Parties

Applicant(s) as Filed:

CANADIAN TIRE CORPORATION, LIMITED

Registered Proprietor(s):

CANADIAN TIRE CORPORATION, LIMITED
2180 YONGE STREET
TORONTO, M4P 2V8
ONTARIO, CANADA

Current Owner(s):

CANADIAN TIRE CORPORATION, LIMITED
2180 YONGE STREET
TORONTO, M4P 2V8
ONTARIO, CANADA

Client Reference Number:
Representative for Service:

37785-0619
CASSELS BROCK & BLACKWELL LLP
2100 - 40 KING STREET WEST
TORONTO, M5H 3C2
ONTARIO, CANADA

Agent:

CASSELS BROCK & BLACKWELL LLP
2100 - 40 KING STREET WEST
TORONTO, M5H 3C2
ONTARIO, CANADA

Term of Protection: 10 years, subject to payment of a maintenance fee.

Maintenance Fee Paid:

No

Filing Date:

2014-09-29

Correction(s):

No

View Document Images:

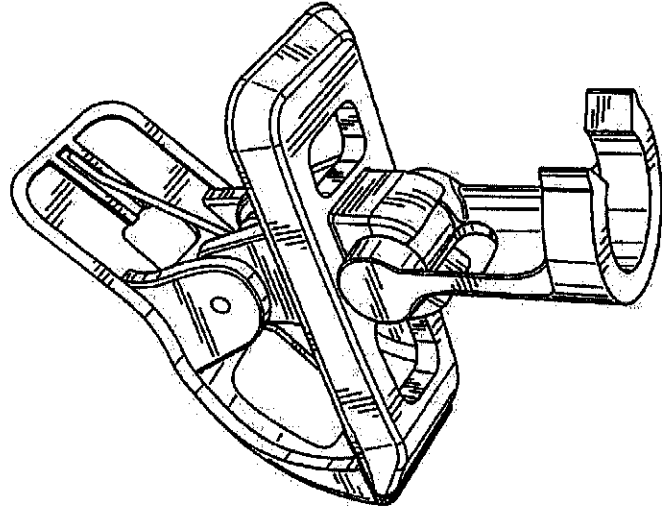

FIG. 2

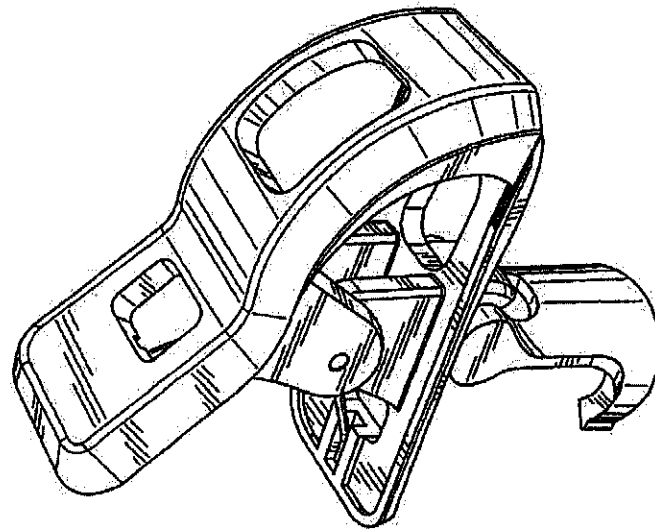

FIG. 1

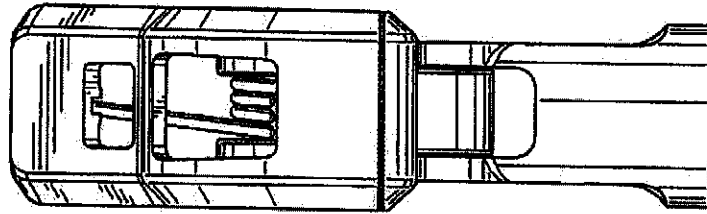

FIG. 4

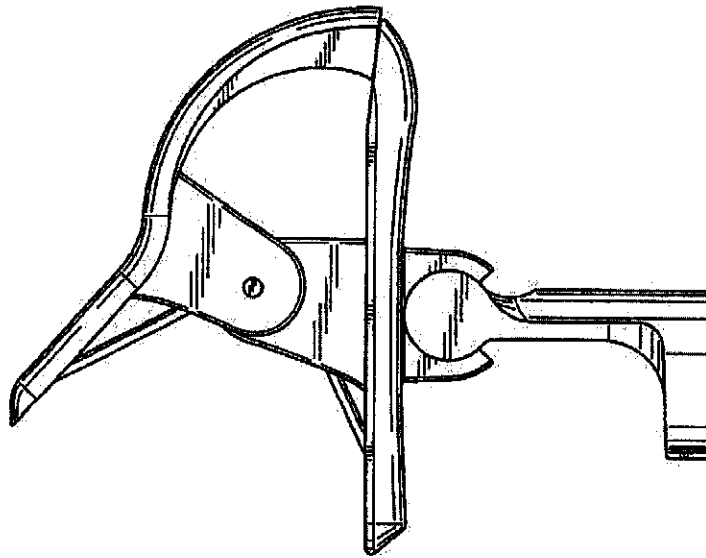

FIG. 3

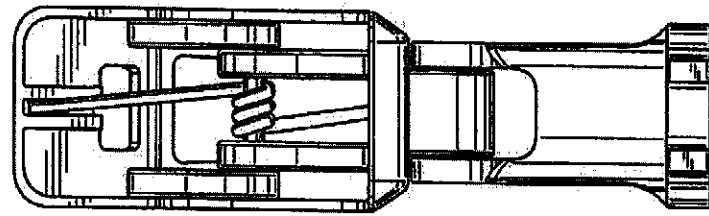

FIG. 6

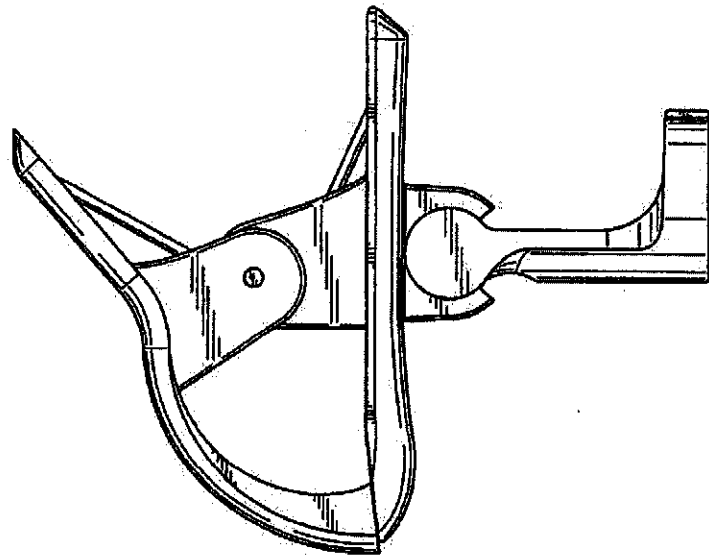

FIG. 5

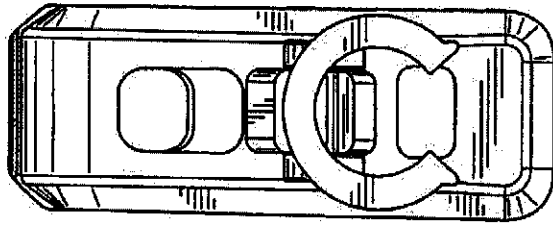

FIG. 8

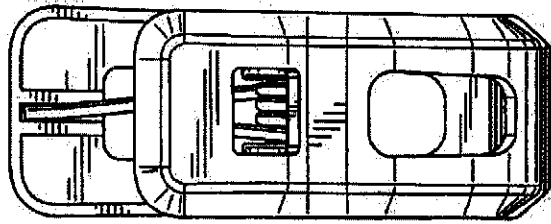

FIG. 7

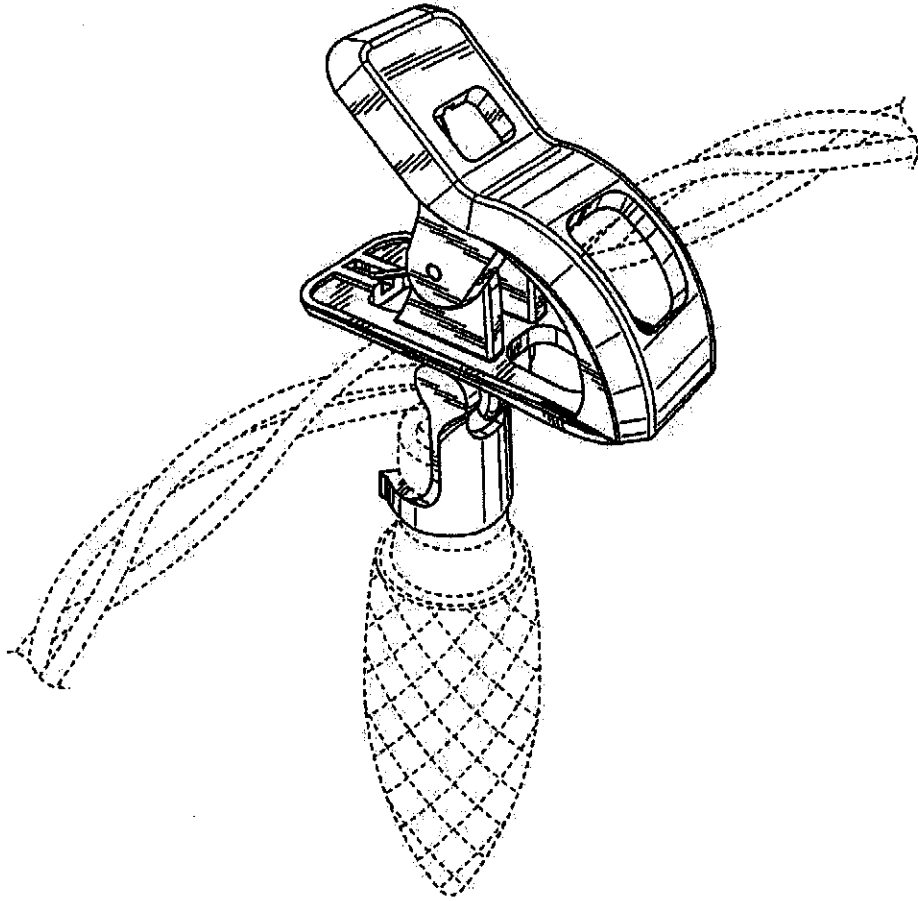
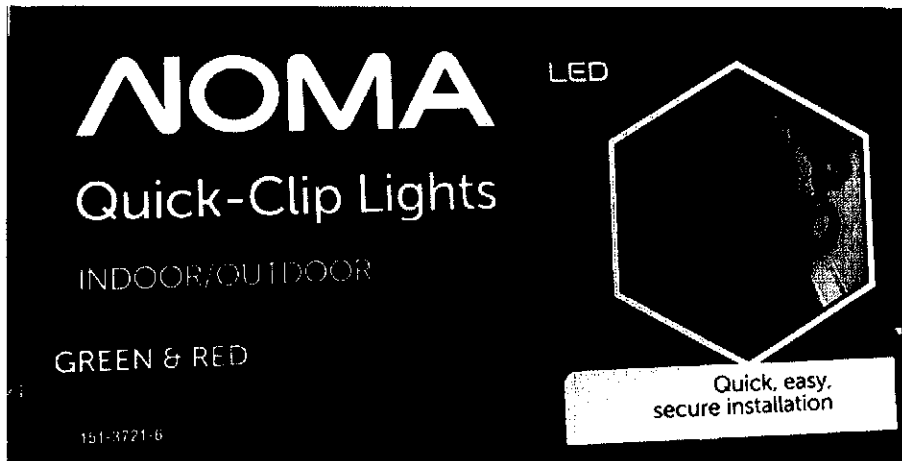
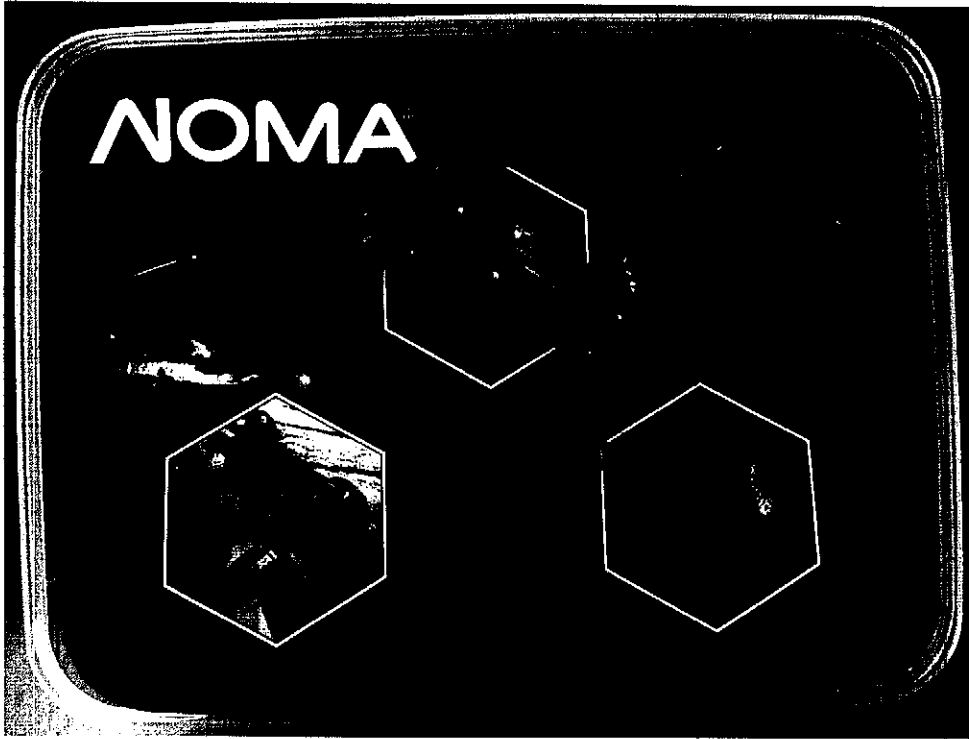

FIG. 9

Schedule "B" – Plaintiff's QUICK-CLIP Trade-marks and Indicia



NOMA

Quick-Clip Lights
Lumières à pince

16' 8" C9 25

LED DEL

RG9

5

151 174

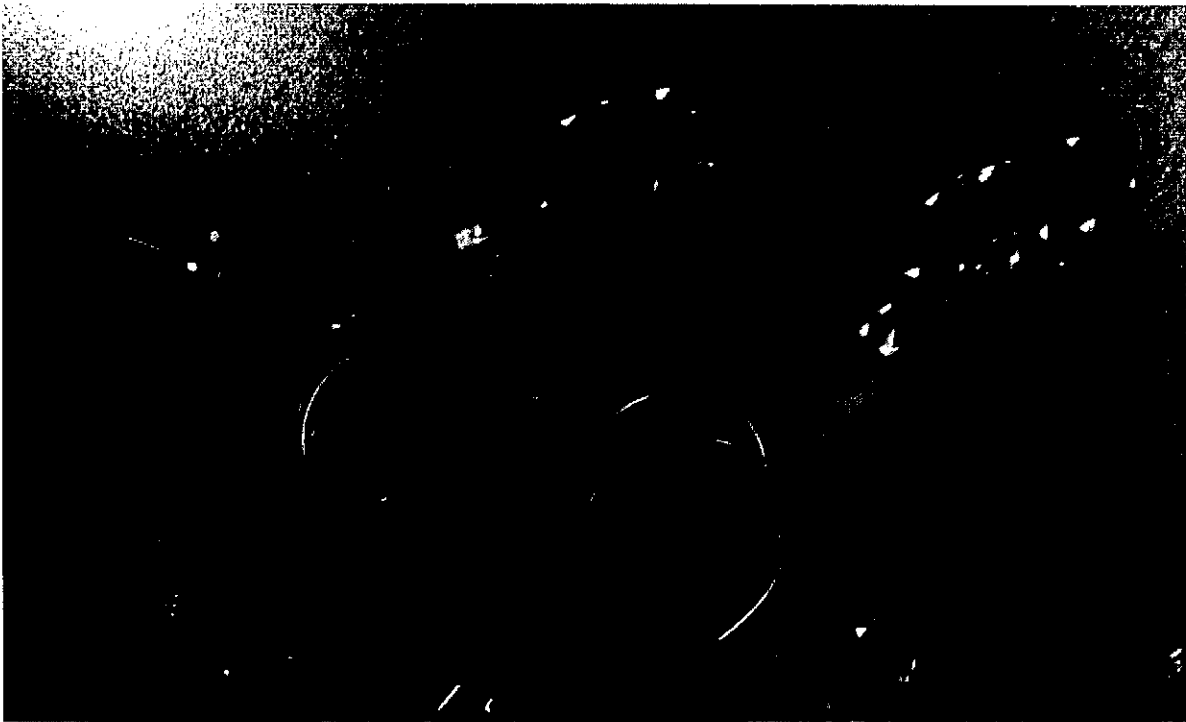

Schedule "C" – Defendants' Infringing "Holiday Time" Products and Packaging

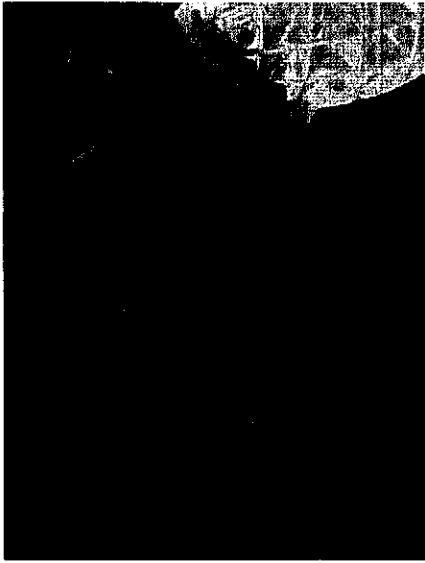

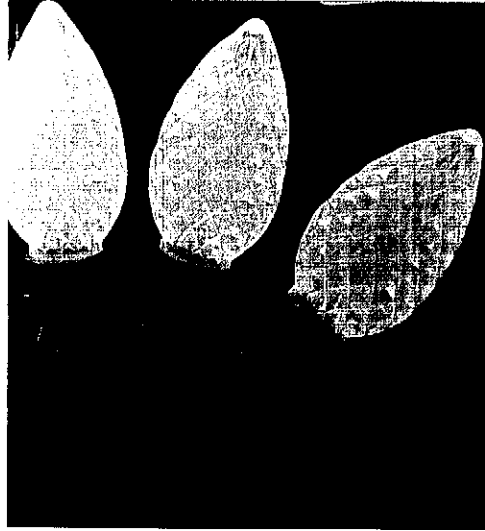

HOLIDAY TIME

Cool White/Blanc Froid
LED C9 LIGHT SET
JEU À LUMIÈRES À DEL C9

\$21

25 LEDs
DEL

Save up to 90%
on energy!
Économisez jusqu'à 90%
sur les énergies!
LED

QUICK CLIPS
FIXATIONS RAPIDES

A string of five LED C9 light bulbs is shown hanging from a central point. The bulbs are teardrop-shaped and appear to be made of a textured material. They are arranged in a slight arc.

HOLIDAY TIME

21

Multi-Colour/Multicolore
LED C9 LIGHT SET
JEU À LUMIÈRES À DEL C9

25 LEDs
DEL

Save up to 90%
on energy!
Économise jusqu'à 90%
sur les énergétiques!

QUICK CLIPS
FIXATIONS RAPIDES

**LED
DEL**

Lighted length 13.8 ft.
Longueur lumineuse
de 4,2 m

Indoor/Outdoor
Intérieur/Extérieur

14.4 ft./4,38 m

Green wire
Fil vert