

NSMC-OPCO, LLC
Natural State Medicinals Cultivation
Cultivation Application



Table of Contents

Cover Page

Proof of Funds

**Bank Statement of \$1.55 Million in Liquid Assets Surety Bond of \$1 Million
Surety Bond**

Section A

Signed Operating Agreement with Equity Division

Section B: Alonzo Dean Williams

Section B, Appendix 1

Section B, Appendix 2

Section B, Appendix 3

Section B, Appendix 3

DEA License

Retail Pharmacy License

College of American Pathologists Laboratory Accreditation

Centers for Medicare and Medicaid Services Histopathology Accreditation

Centers for Medicare and Medicaid Services Toxicology

Arkansas State Background Check

Section B: Clifton Bolen Peck IV

Section B, Appendix 1

Section B, Appendix 2

Section B, Appendix 3

Section B, Appendix 3

DEA License #1

DEA License #2

DEA License #3

DEA License #4

DEA License #5

DEA License #6

DEA License #7

DEA License #8

DEA License #9

DEA License #10

Louisiana State University Veterinary Diploma

Arkansas Veterinary Medicine and Surgery License

MEMS Award

FBI Award

Arkansas State Background Check

Section B: Donald Keith Mooney

Section B, Appendix 1

Section B, Appendix 2

Section B, Appendix 3
Section B, Appendix 3
DEA License
Arkansas Medical License
Arkansas State Background Check

Section B: Donna Ann Terrell
Section B, Appendix 1
Section B, Appendix 2
Section B, Appendix 3
Section B, Appendix 3
Arkansas State Background Check

Section B: Donna Mae Mooney
Section B, Appendix 1
Section B, Appendix 2
Section B, Appendix 3
Section B, Appendix 3
Arkansas State Background Check

Section B: Joseph Charles Courtright
Section B, Appendix 1
Section B, Appendix 2
Section B, Appendix 3
5 Section B, Appendix 3
Arkansas Pharmacist License
Kansas Pharmacist License
Missouri Pharmacist License
Oklahoma Pharmacist License
Controlled Substance Distribution Permits
Regulated Permits
Arkansas State Background Check

Section B: Kathyne Deane Peck
Section B, Appendix 1
Section B, Appendix 2
Section B, Appendix 3
Section B, Appendix 3
Arkansas State Background Check

Section B: Kelli Plumlee Schlesinger
Section B, Appendix 1
Section B, Appendix 2
Section B, Appendix 3
Section B, Appendix 3
DEA License
Arkansas Medical License
Arkansas State Background Check

Section B: Robert Wayne deBin III
Section B, Appendix 1
Section B, Appendix 2
Section B, Appendix 3
Section B, Appendix 3
Qualified Integrators and Resellers Certificate
Arkansas State Background Check

Section B: Scott Michael Schlesinger
Section B, Appendix 1
Section B, Appendix 2
Section B, Appendix 3
Section B, Appendix 3
DEA License
Arkansas Medical License
Arkansas State Background Check

Section B: Stephen Lee LaFrance
Section B, Appendix 1
Section B, Appendix 2
Section B, Appendix 3
Section B, Appendix 3
Arkansas State Background Check

Section B: Susan Diane Williams
Section B, Appendix 1
Section B, Appendix 2
Section B, Appendix 3
Section B, Appendix 3
Arkansas State Background Check

Section B: Wendy Perdue LaFrance
Section B, Appendix 1
Section B, Appendix 2
Section B, Appendix 3
Section B, Appendix 3
Arkansas State Background Check

Section B: Andrew John Salini
Section B, Appendix 1
Section B, Appendix 2
MED Badge
Arkansas State Background Check

Section B: Harry Earnest “Bud” Cummins
Section B, Appendix 1
Section B, Appendix 2
Arkansas State Background Check

Section B: Frank Edward Groves
Section B, Appendix 1
Section B, Appendix 2
Arkansas State Background Check

Section B: Joshua Lauden Risley
Section B, Appendix 1
Section B, Appendix 2
MED Badge
Arkansas State Background Check

Section B: Lance Tyler Huey
Section B, Appendix 1
Section B, Appendix 2
Arkansas State Background Check

Section B: Terence Anthony Fitch
Section B, Appendix 1
Section B, Appendix 2
Arkansas State Background Check

Section C

Section C. Part 1. Written Statement from the Property Owner
Section C. Part 2. Proof Proposed Location is 3,000 feet from all Churches, Schools, and Daycares
Section C. Part 2. Report and Survey of the Location

Section D

Section E

Schedule 1
Schedule 2
Schedule 3
Schedule 4
Schedule 5
Schedule 6
Schedule 7

Exhibits



Proof Of Funds - NSMC-OPCO Bank
Statement of \$1.55M in Liquid Assets (2of2)

[REDACTED]

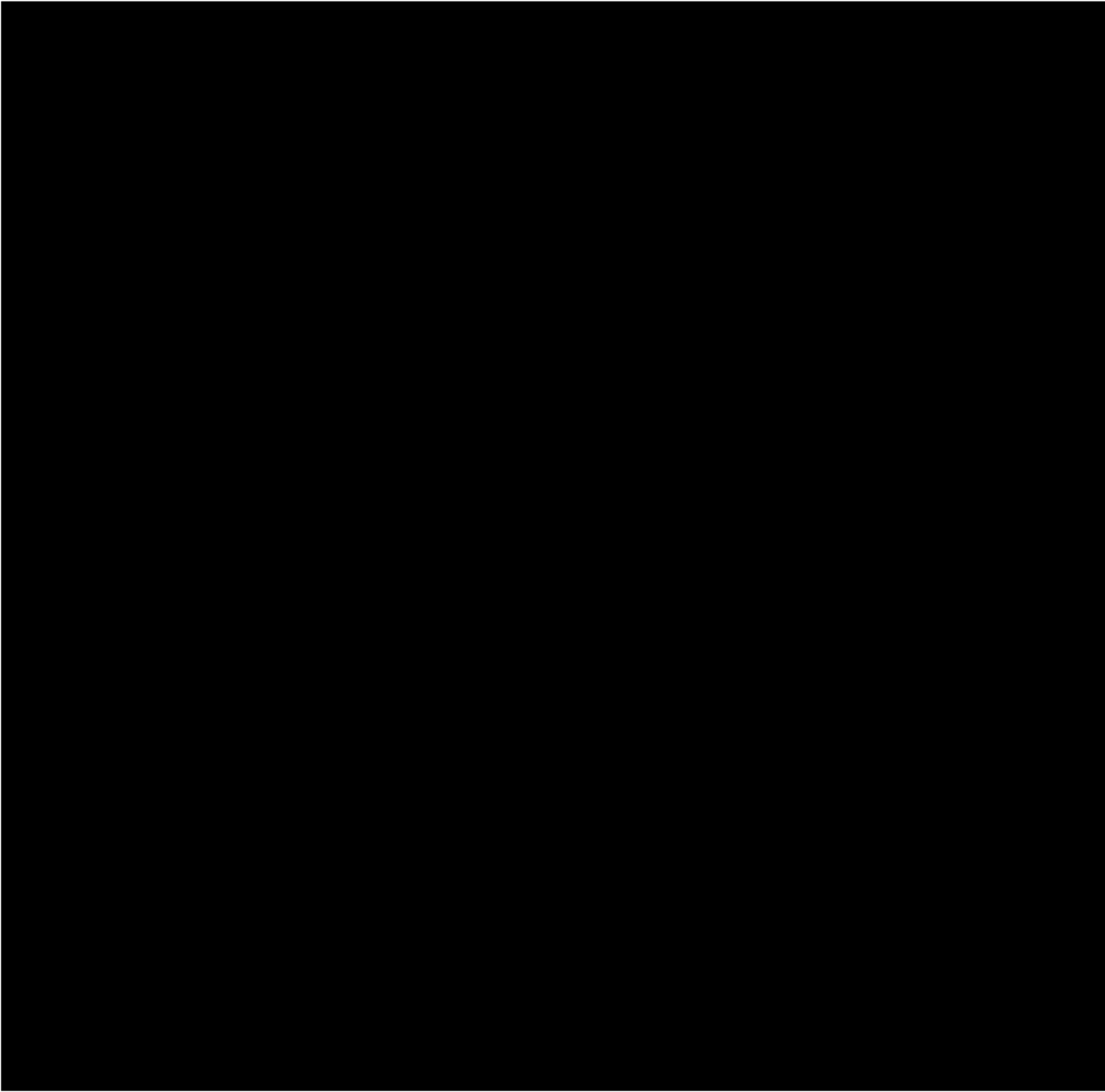

**SURETY BOND PRE-APPROVAL
Medical Marijuana Cultivation Facility**

KNOW ALL PEOPLE BY THESE PRESENTS, that NSMC-OPCO, LLC
(a corporation of the State of Arkansas) (individual), (partnership) (hereinafter
referred to as the "Principal"), and Hudson Insurance Company, a corporation of the State of Delaware

Name of Surety

(hereinafter referred to as the "Surety"), are held and firmly bound unto the State of Arkansas, for
Department of Finance and Administration, Arkansas Medical Marijuana Commission (hereinafter
referred to as "MMC"), in the amount of One Million Dollars, for the payment of which the
Principal and the Surety bind themselves, their heirs, executors, administrators, successors and
assigns, jointly and severally, firmly by these presents.

The conditions of this obligation are such that, whereas the Principal has submitted, or is about
to submit, to the State of Arkansas an application for a medical marijuana cultivation facility and
submits this bond as partial or full proof of assets in the amount of one million dollars
(\$1,000,000.00).

- (1) If said application is denied by the MMC, then this obligation shall be void.
- (2) If said application is granted and the MMC awards the Principal with a license, the Principal shall furnish a bond in the amount of five hundred thousand dollars (\$500,000.00) for the Principal's faithful performance of said license, and for the payment of all persons performing labor or furnishing materials in connection therewith, and shall in all other respects perform the agreement created by the acceptance of said bid, then this obligation shall be void.

IN WITNESS WHEREOF, the Principal and the Surety have hereunto set their hands and seals,
and such of them as are corporations have caused their corporate seals to be hereto affixed and
these presents to be signed by their proper officers, on the day and year set forth below.

SEAL: NSMC-OPCO, LLC 8-25-17
Principal Date

By:  Christina

SEAL: Hudson Insurance Company 8/18/2017
Name of Surety Date

By:  Michael J. Herranen, Attorney-in-Fact

NOTE TO SURETY AND PRINCIPAL: The application submitted, which this bond guarantees,
may be rejected if the following instrument is not attached to this bond: Power of Attorney
showing that the agent of Surety is currently authorized to execute bonds on behalf of the Surety,
and in the amounts referenced above.

Proof of Funds - Surety Bond
of \$1M and Performance
Bond (page 2 of 2)



POWER OF ATTORNEY

KNOW ALL MEN BY THESE PRESENTS: That HUDSON INSURANCE COMPANY, a corporation of the State of Delaware, with offices at 100 William Street, New York, New York, 10038, has made, constituted and appointed, and by these presents, does make, constitute and appoint

Michael J. Herranen
of the State of AZ

its true and lawful Attorney(s)-in-Fact, at New York, New York, each of them alone to have full power to act without the other or others, to make, execute and deliver on its behalf, as Surety, bonds and undertakings given for any and all purposes, also to execute and deliver on its behalf as aforesaid renewals, extensions, agreements, waivers, consents or stipulations relating to such bonds or undertakings provided, however, that no single bond or undertaking shall obligate said Company for any portion of the penal sum thereof in excess of the sum of
One Million Dollars (\$1,000,000.00)

Such bonds and undertakings when duly executed by said Attorney(s)-in-Fact, shall be binding upon said Company as fully and to the same extent as if signed by the President of said Company under its corporate seal attested by its Secretary.

In Witness Whereof, HUDSON INSURANCE COMPANY has caused these presents to be of its Executive Vice President thereunto duly authorized, on this 31st day of October, 2013 at New York, New York.



Dina Daskalakis
Corporate Secretary

Dina Daskalakis

HUDSON INSURANCE COMPANY

By *Christopher T. Suarez*
Christopher T. Suarez
Executive Vice President

STATE OF NEW YORK
COUNTY OF NEW YORK. SS.

On the 31st day of October, 2013 before me personally came Christopher T. Suarez to me known, who being by me duly sworn did depose and say that he is an Executive Vice President of HUDSON INSURANCE COMPANY, the corporation described herein and which executed the above instrument, that he knows the seal of said Corporation, that the seal affixed to said instrument is such corporate seal, that it was so affixed by order of the Board of Directors of said Corporation, and that he signed his name thereto by like order

(Notarial Seal)



Ann M. Murphy
ANN M. MURPHY
Notary Public, State of New York
No. 01MU6067553
Qualified in Nassau County
Commission Expires December 10, 2017

STATE OF NEW YORK
COUNTY OF NEW YORK

CERTIFICATION

The undersigned Dina Daskalakis hereby certifies:

That the original resolution, of which the following is a true and correct copy, was duly adopted by unanimous written consent of the Board of Directors of Hudson Insurance Company dated July 27th, 2007, and has not since been revoked, amended or modified

"RESOLVED, that the President, the Executive Vice Presidents, the Senior Vice Presidents and the Vice Presidents shall have the authority and discretion, to appoint such agent or agents, or attorney or attorneys-in-fact, for the purpose of carrying on this Company's surety business, and to empower such agent or agents, or attorney or attorneys-in-fact, to execute and deliver, under this Company's seal or otherwise, bonds obligations, and recognizances, whether made by this Company as surety thereon or otherwise, indemnity contracts, contracts and certificates, and any and all other contracts and undertakings made in the course of this Company's surety business, and renewals, extensions, agreements, waivers, consents or stipulations regarding undertakings so made, and

FURTHER RESOLVED, that the signature of any such Officer of the Company and the Company's seal may be affixed by facsimile to any power of attorney or certification given for the execution of any bond, undertaking, recognizance, contract of indemnity or other written obligation in the nature thereof or related thereto, such signature and seal when so used whether heretofore or hereafter, being hereby adopted by the Company as the original signature of such officer and the original seal of the Company, to be valid and binding upon the Company with the same force and effect as though manually affixed."

THAT the above and foregoing is a full, true and correct copy of Power of Attorney issued by said Company, and of the whole of the original and that the said Power of Attorney is still in full force and effect and has not been revoked, and furthermore that the Resolution of the Board of Directors, set forth in the said Power of Attorney is now in force.

Witness the hand of the undersigned and the seal of said Corporation this 18th day of August, 2017



Dina Daskalakis
Dina Daskalakis, Corporate Secretary

APPLICATION FOR MEDICAL MARIJUANA CULTIVATION FACILITY

SECTION A. GENERAL INFORMATION

- 1. Name of Applicant** (Must be a natural person.)

Joseph Charles Courtright

- 2. Business Name** NSMC-OPCO, LLC

Fictitious Trade Name (if any) Natural State Medicinals Cultivation

Business Mailing Address One Allied Drive, Suite 1720

Little Rock, AR 72202

Business telephone number 501-492-4667

- 3. Business entity type** Limited Liability Company

Date of business formation or incorporation 8-3-2017

State(s) of Incorporation Arkansas

Registered Agent Name Joseph C Courtright

Registered Agent Address One Allied Drive, Suite 1720, Little Rock, AR 72202

4. **List all owners, stockholders, shareholders, members, officers, and board members of the proposed cultivation facility. Identify the nature of the individual's or corporation's affiliation with the proposed cultivation facility and the percentage of ownership, if any. NOTE: Please make sure that 100% of the ownership interest in the proposed cultivation facility is accounted for in this section. (Attach any necessary additional pages to this form. Include a header on any attachments. The header for this response should include "Section A. Number 4.")**

Dr. Joseph Charles Courtright, P.D. Applicant, Chairman and CEO 15.72% Owner

Stephen Lee LaFrance 5.66% Owner

Wendy Perdue LaFrance 10.07% Owner

Dr. Scott Michael Schlesinger, M.D. 5.66% Owner. Member of Medical Board

Dr. Kelli D Schlesinger, M.D. 10.07% Owner, Chairman of Medical Board

Dr. Clifton Bolen Peck, DVM. 4.23% Owner

Kathryne Deane Peck, RDN 7.51% Owner

Robert DeBin 4.46% Owner, Vice President IT & Business Development, Board of Directors

Dr. Donald Keith Mooney, MD 4.23% Owner, Member of Medical Board

Dr. Donna Mae Mooney, PhD. 7.51% Owner, Board of Directors, Member of Medical Board

Dr. Alonzo Dean Williams Sr., MD 8.45% Owner, Member of Medical Board

Susan D. Williams, 15.02% Owner, Board of Directors

Donna Terrell 1.41% Owner, Board of Directors, Vice President of Community Outreach

5. **County of Proposed Location** Jefferson

6. **City of Proposed Location (If inside city limits)** Not located within city limits

7. **Has the applicant or business entity filed, or does the applicant or business entity intend to file an additional application for a cultivation facility license, under the same or a different name at a different location? If so, please provide the location(s) and any other name under which the application(s) will be made.**

No

8. **Is the Applicant or any owner, stockholder, shareholder, officer, or board member in any way affiliated with any other applicant(s) for**

dispensaries/cultivation centers? If yes, please identify the individual and the name of the proposed cultivation facility or dispensary, and briefly describe the nature of the relationship.

No

Certification

I, Joseph Charles Courtright, certify that the information provided in this form and its attachments is complete and accurate. I understand that any misstatement or concealment of fact may be grounds for refusal of application or revocation of license if later disclosed.

Signed this 29th day of August, 2017.

Joseph Charles Courtright
Signature of Applicant

Subscribed and sworn to before me this 29th day of August, 2017.

Lindsey Forbes
Notary Public

My Commission Expires: November 26th, 2026

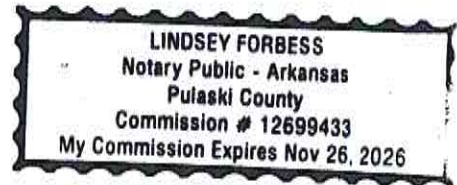

AMENDED AND RESTATED
OPERATING AGREEMENT
OF
NSMC-OPCO, LLC

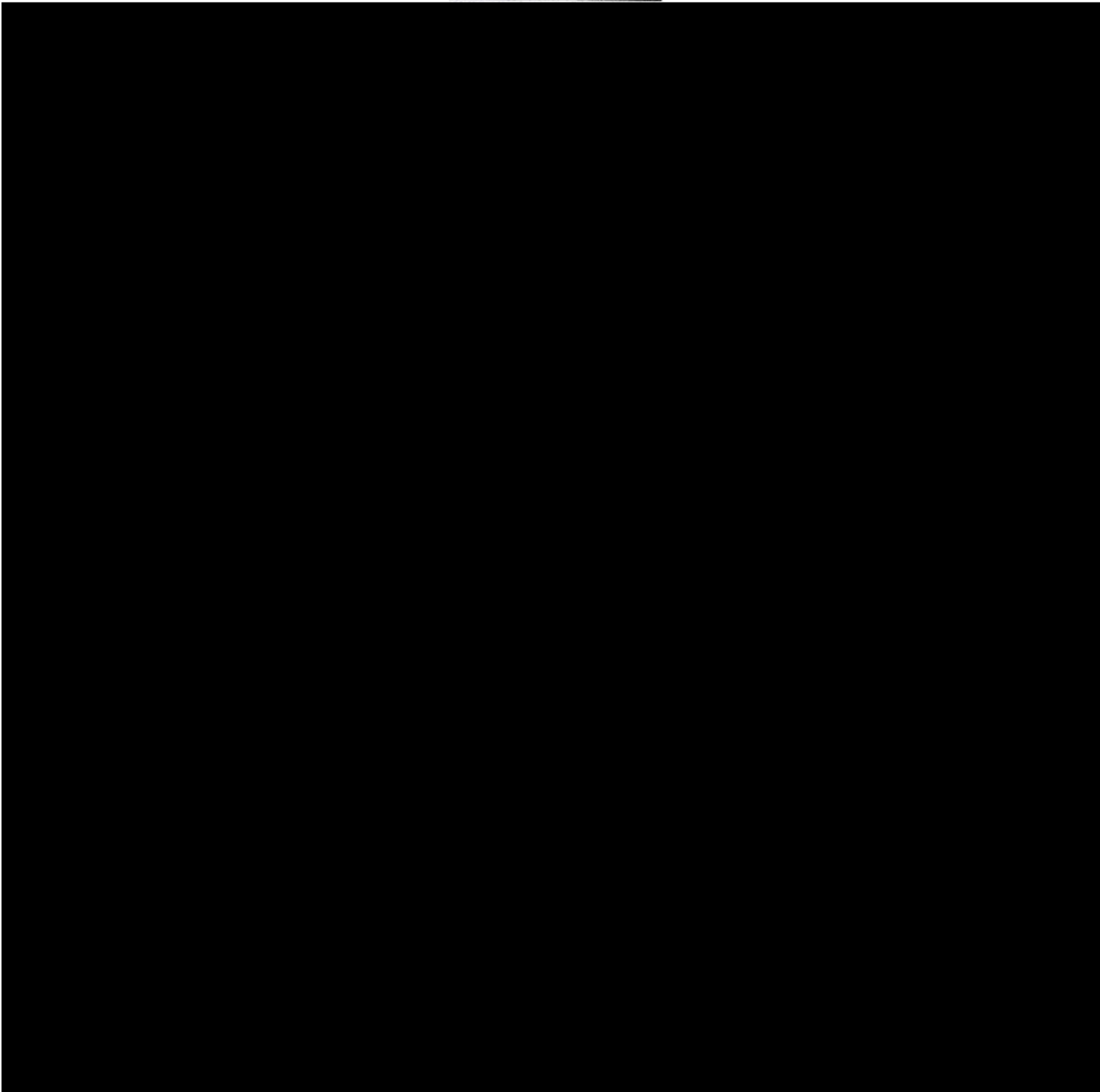

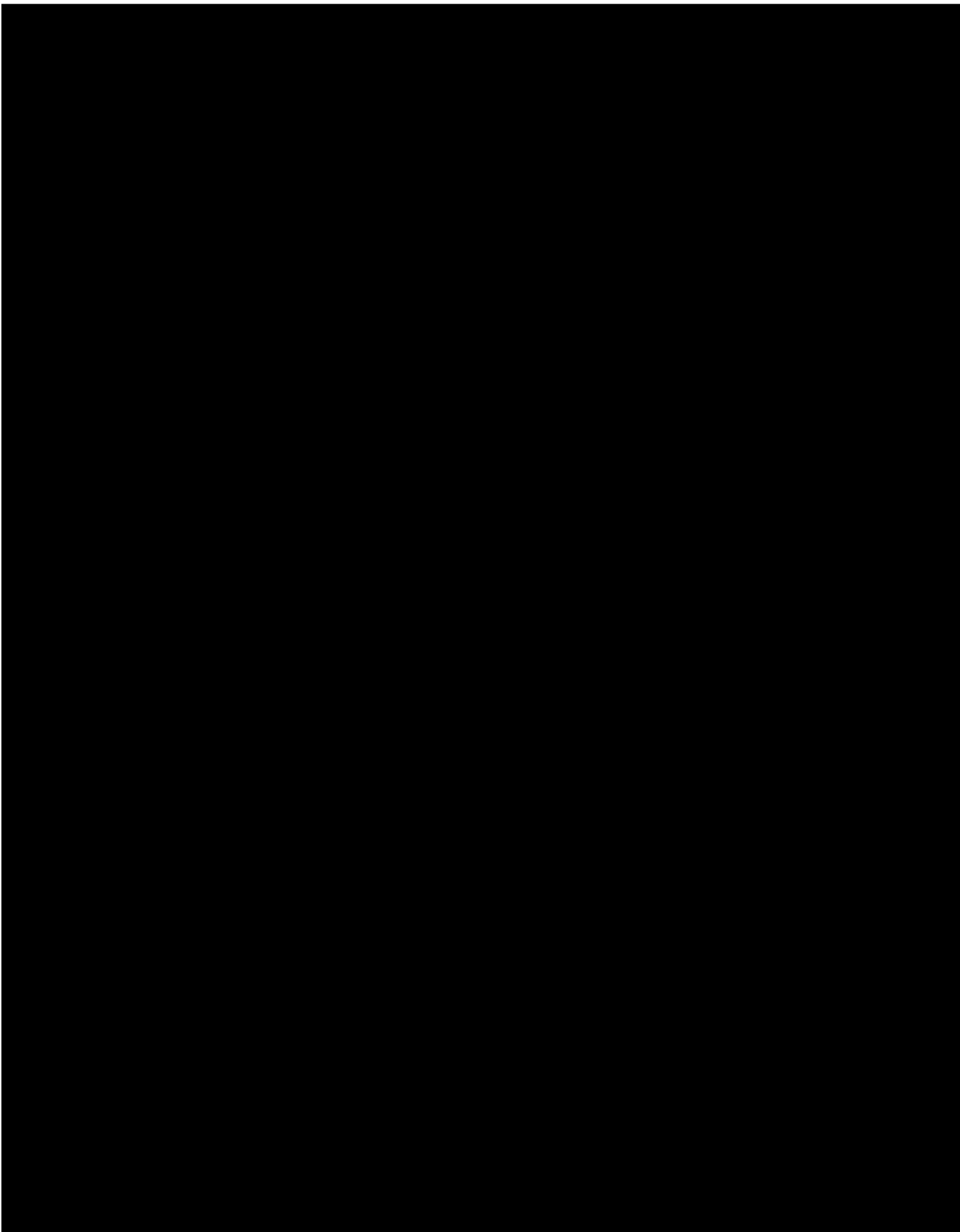

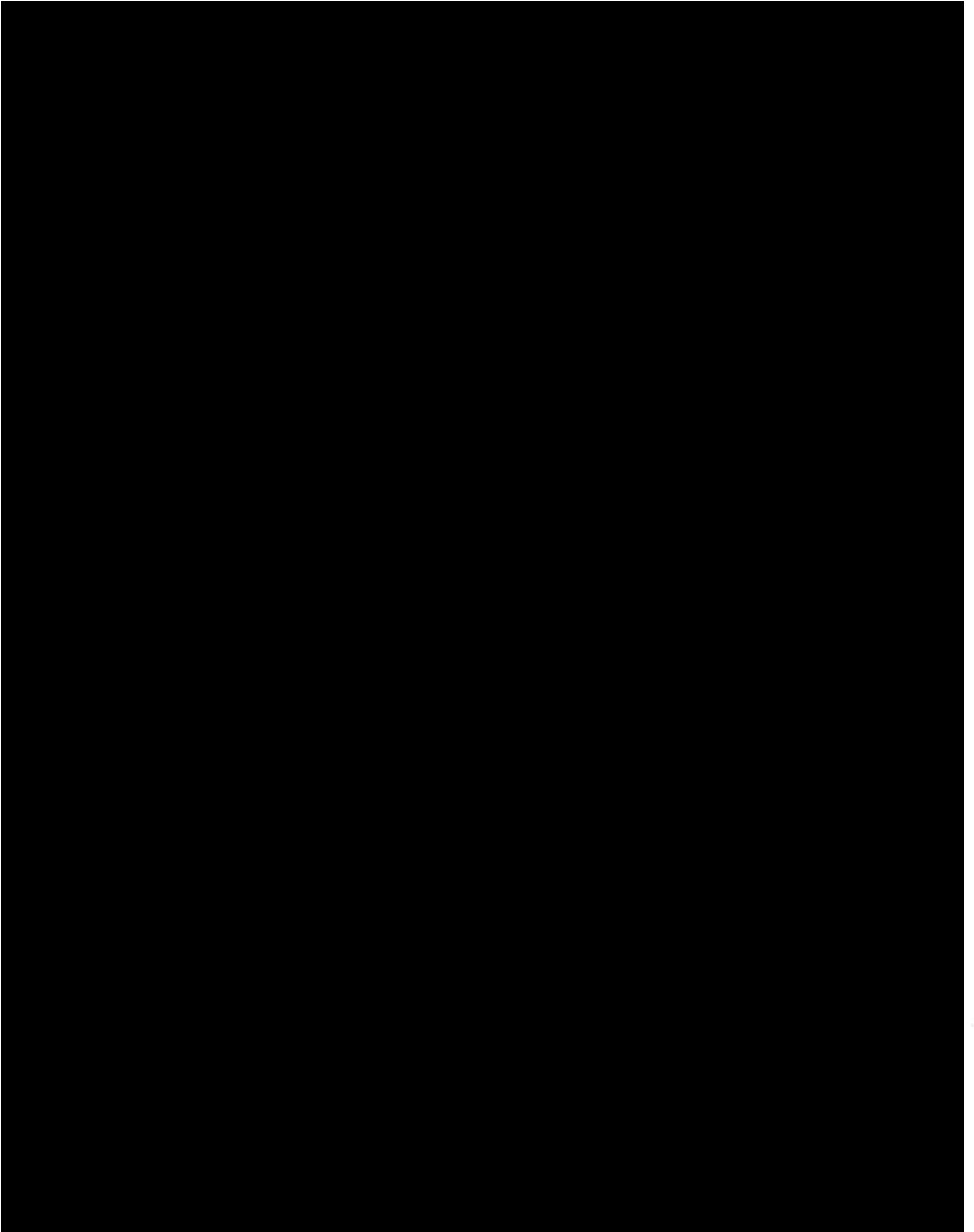

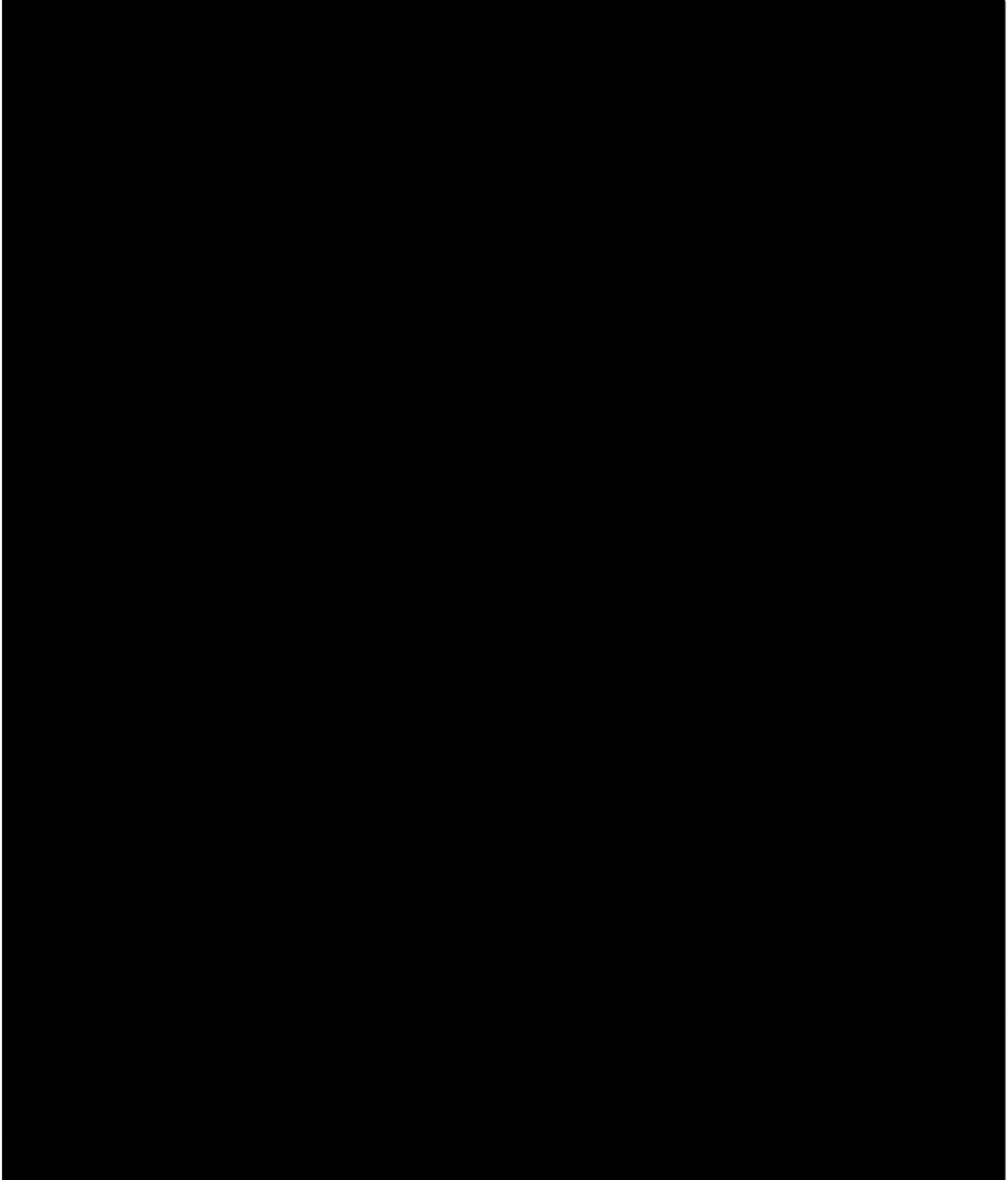

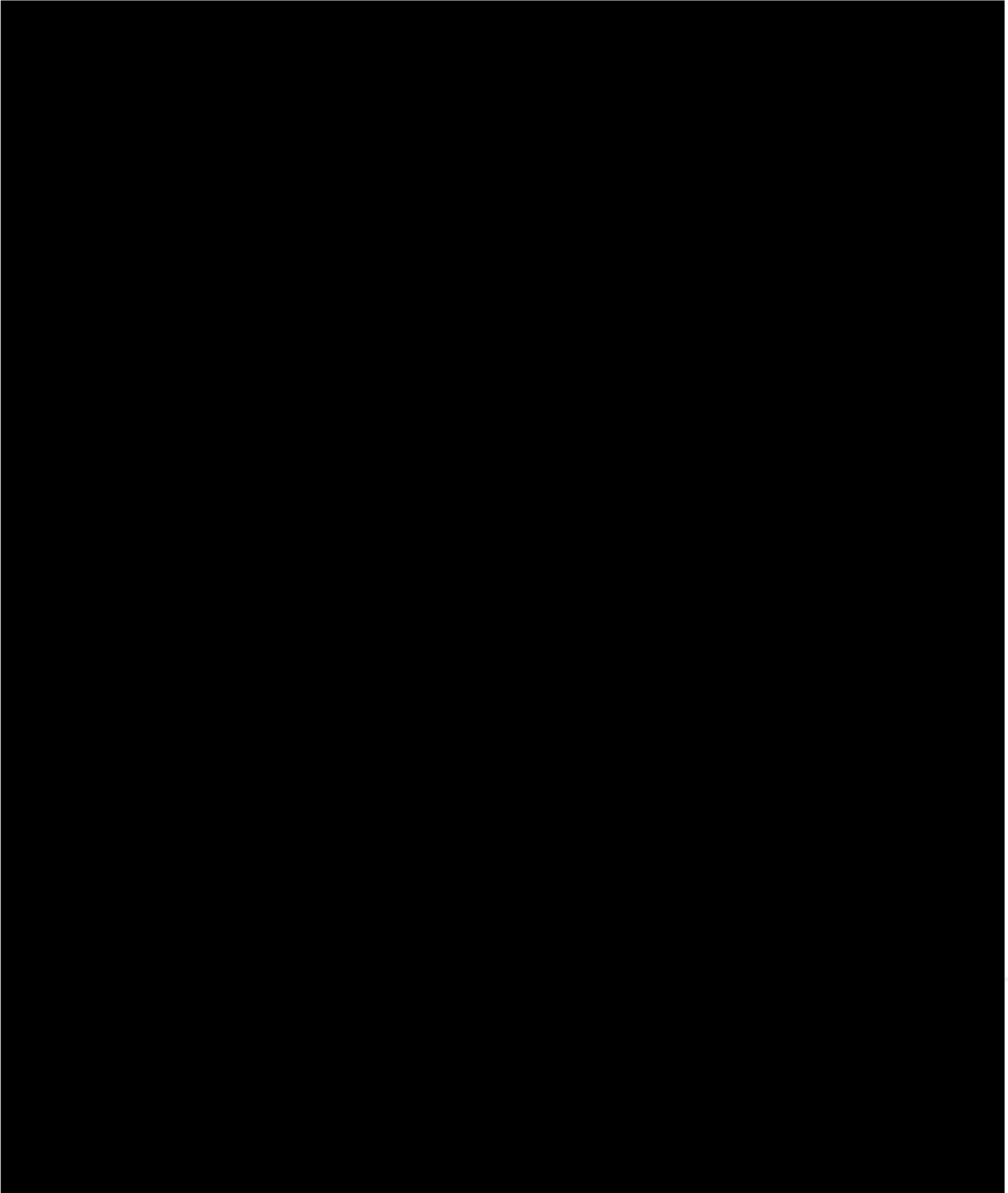

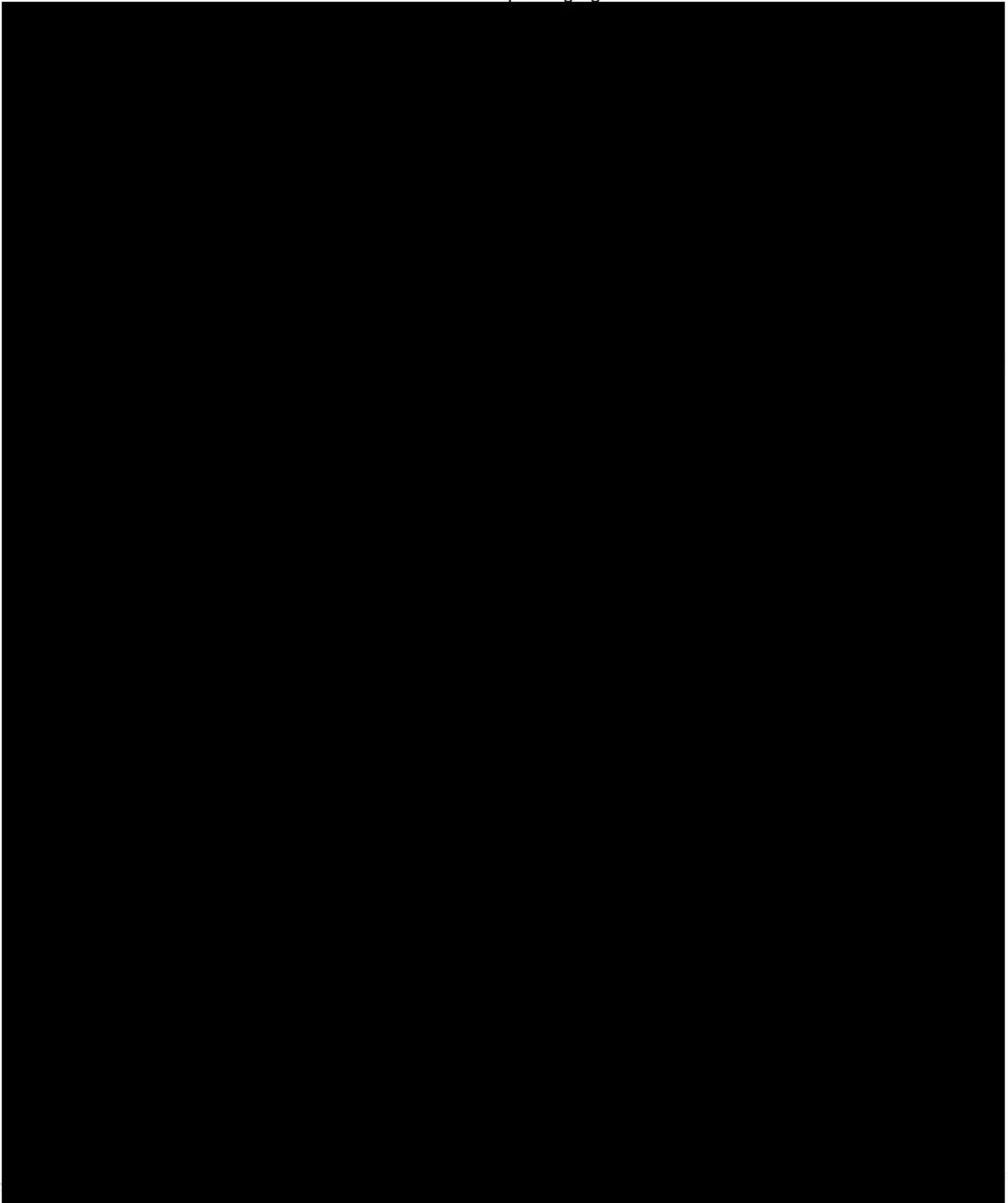

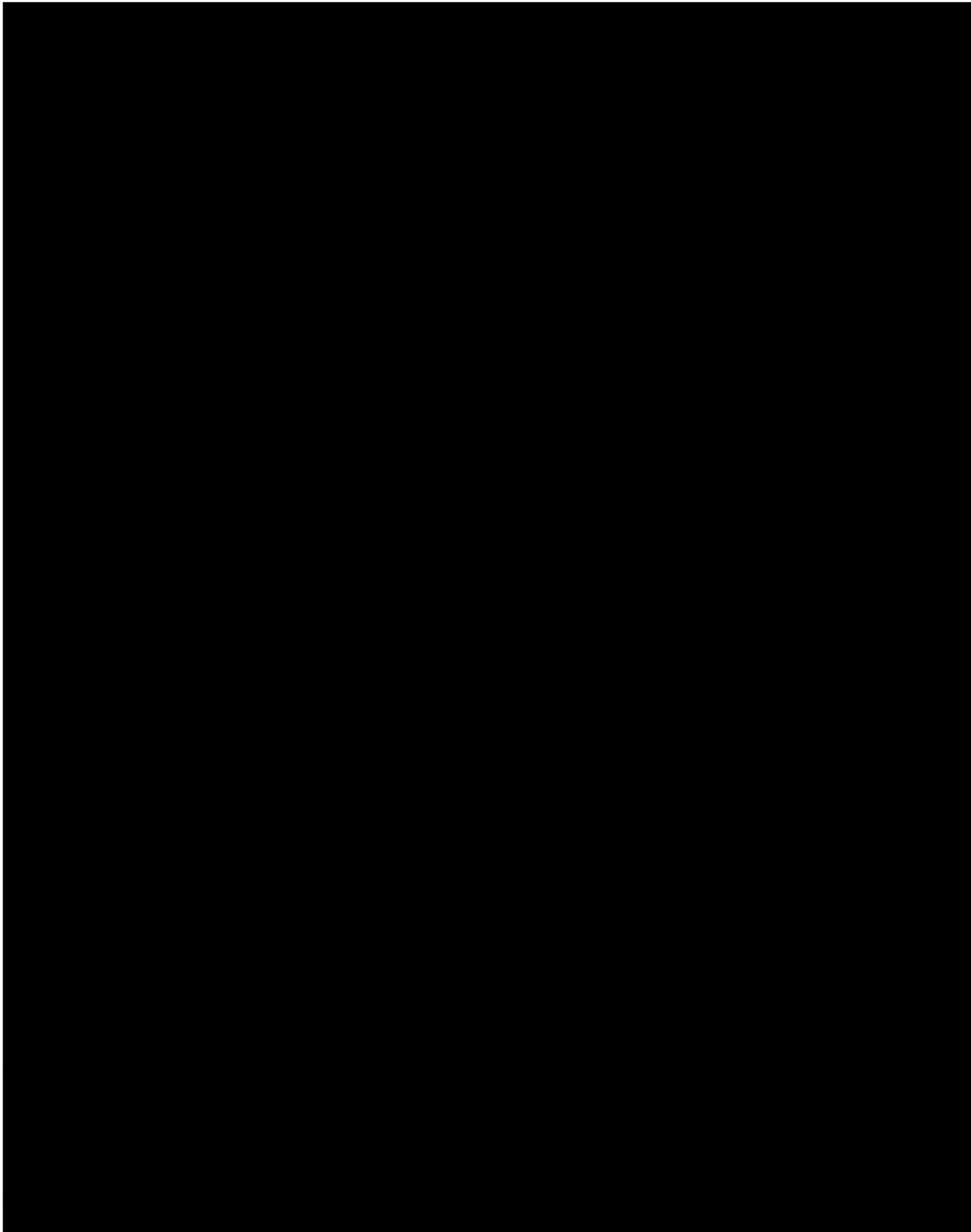

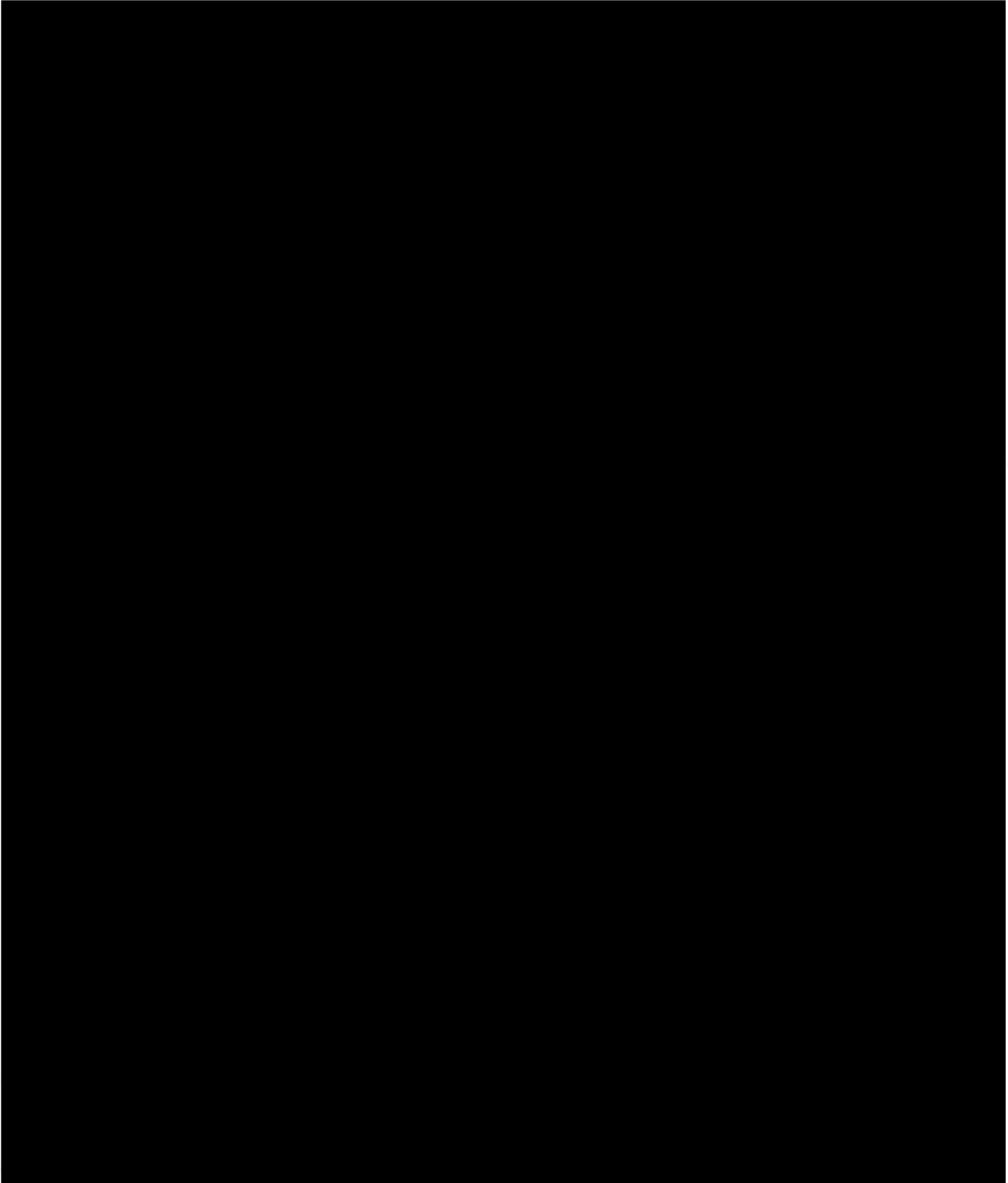

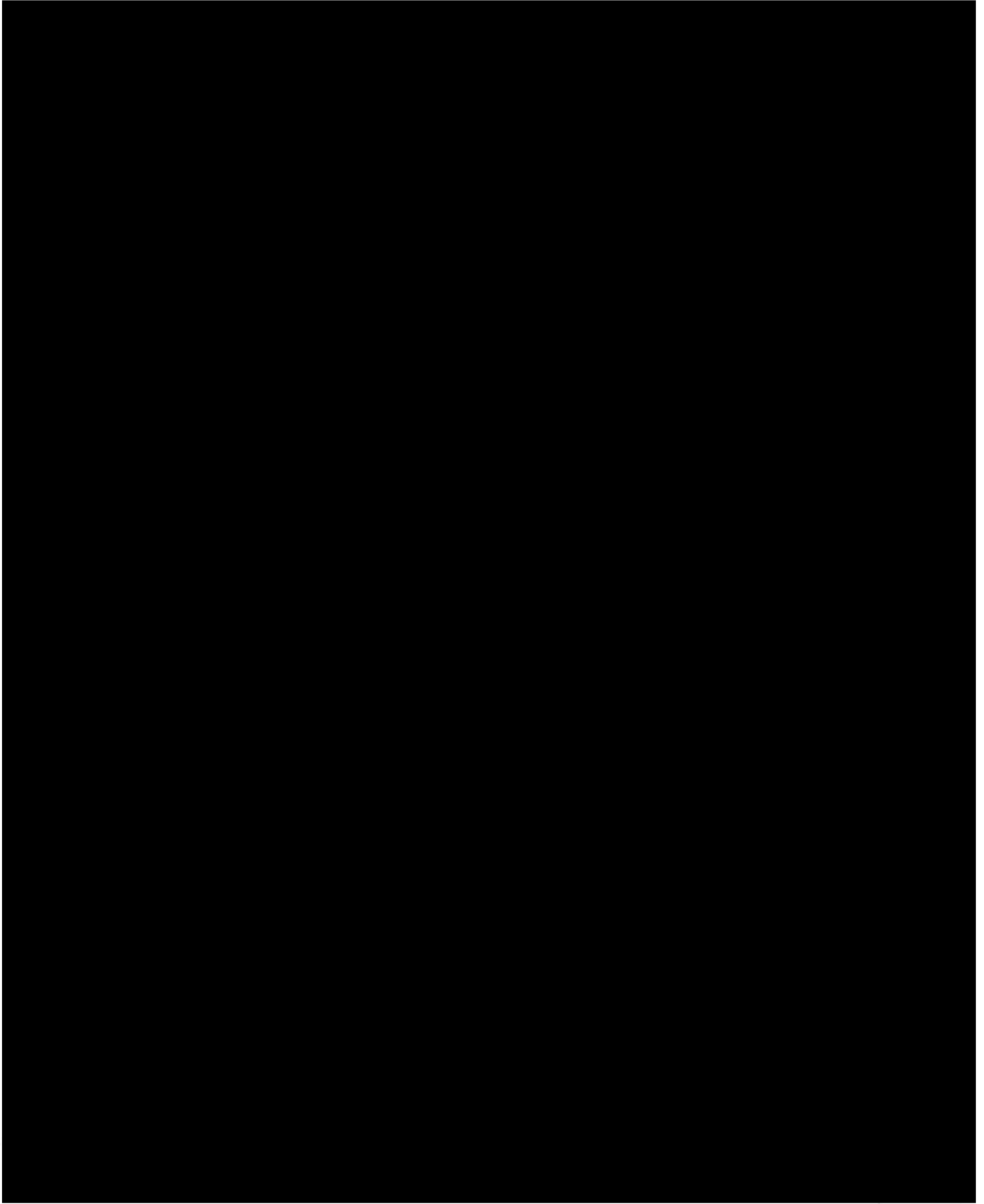

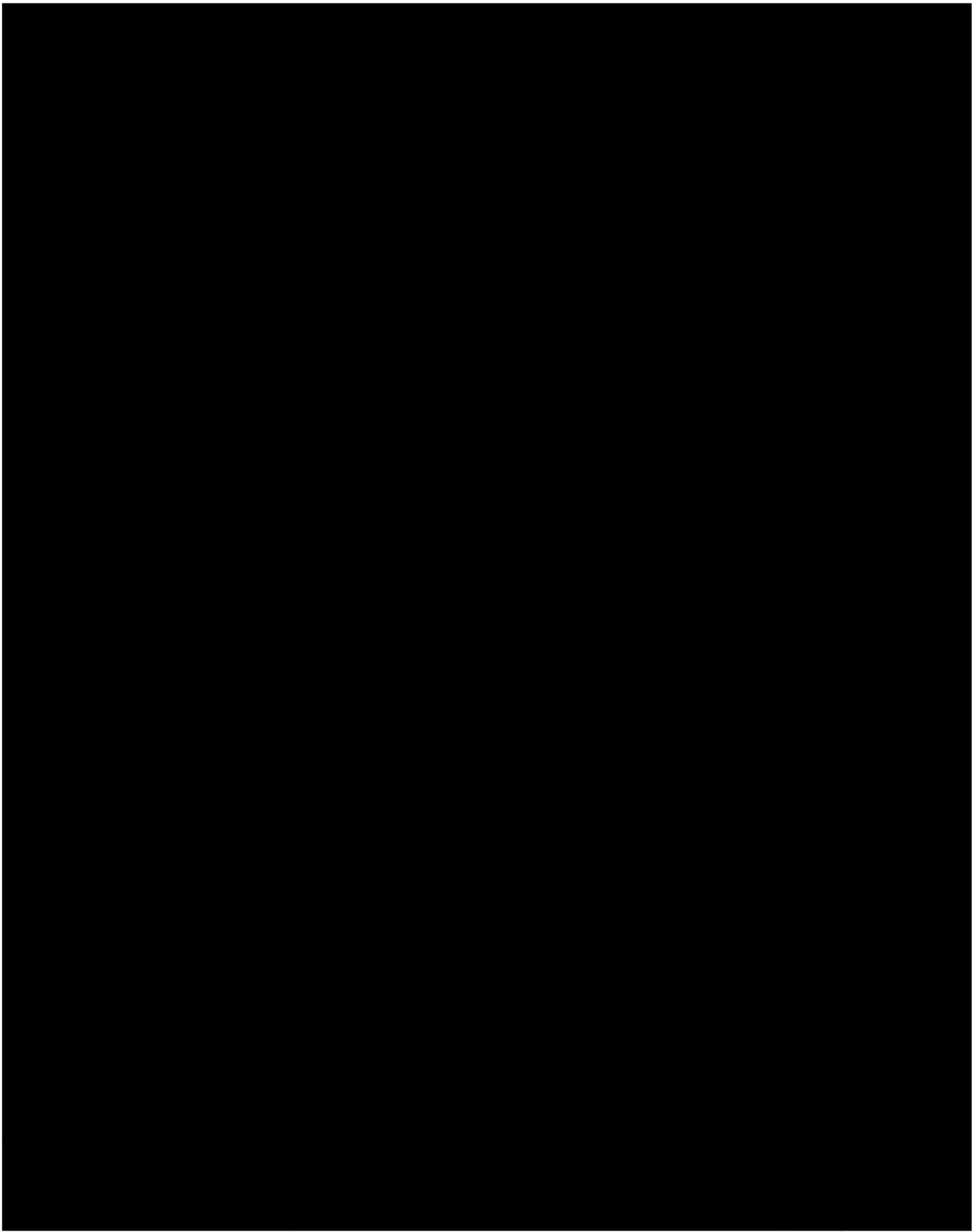

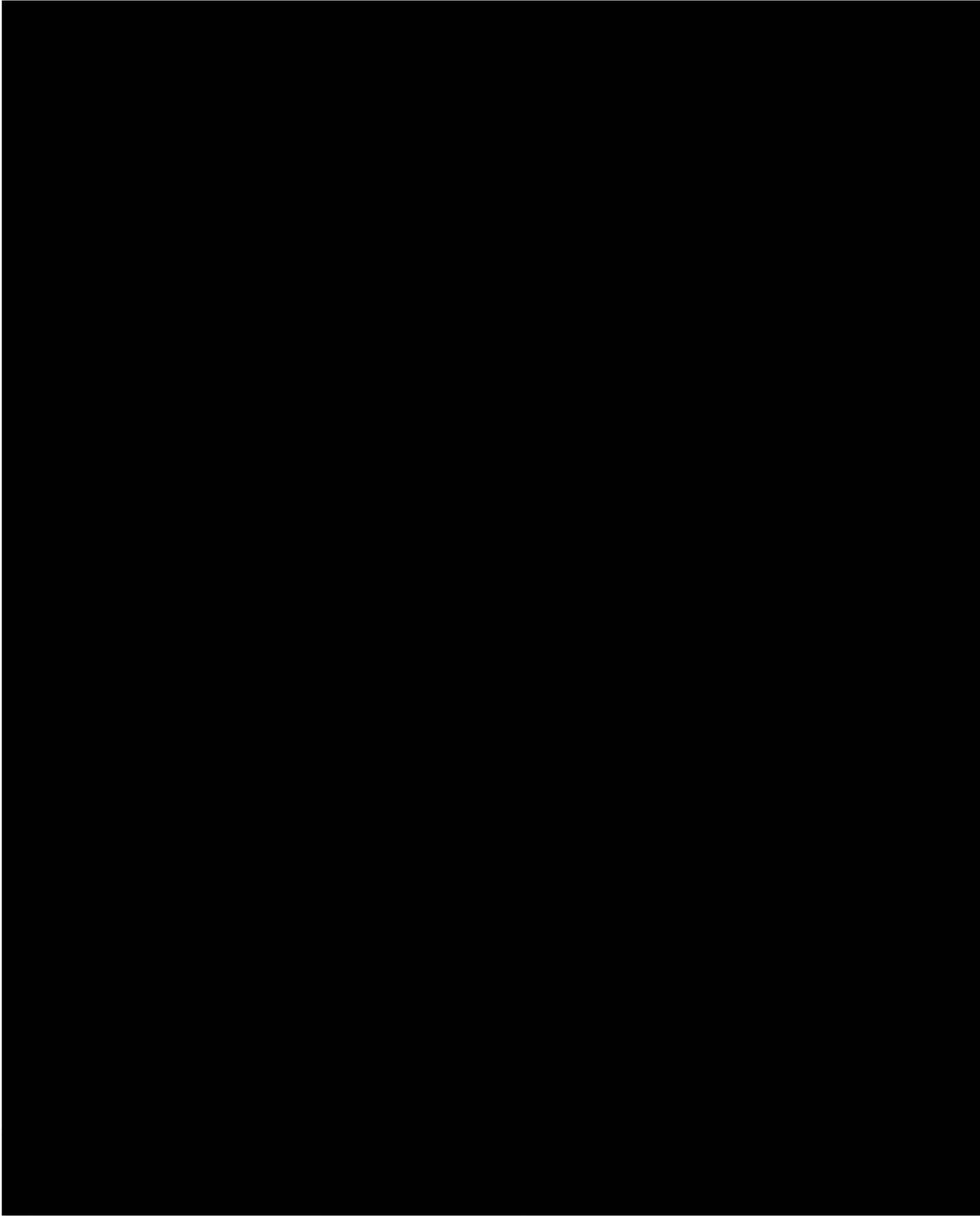

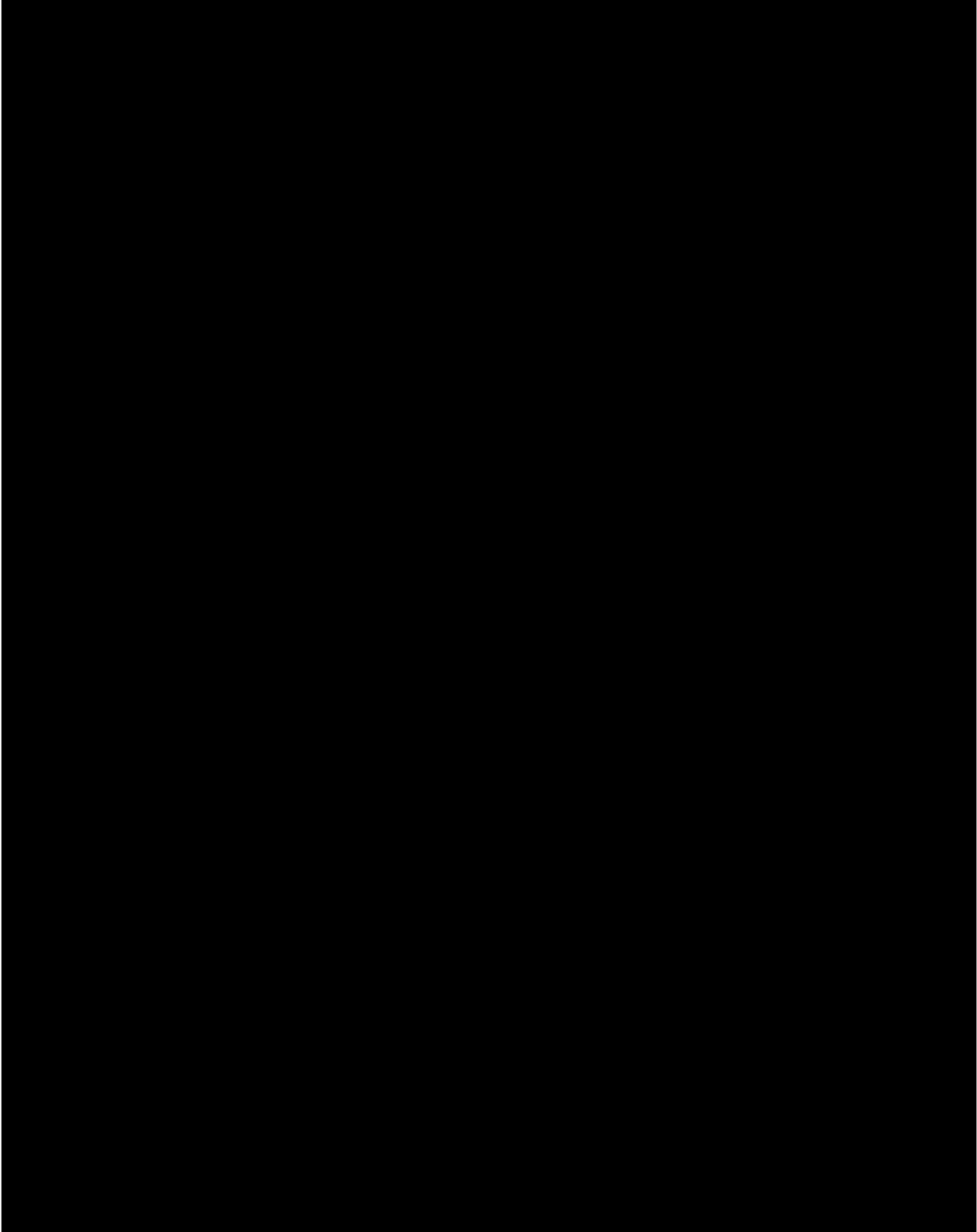

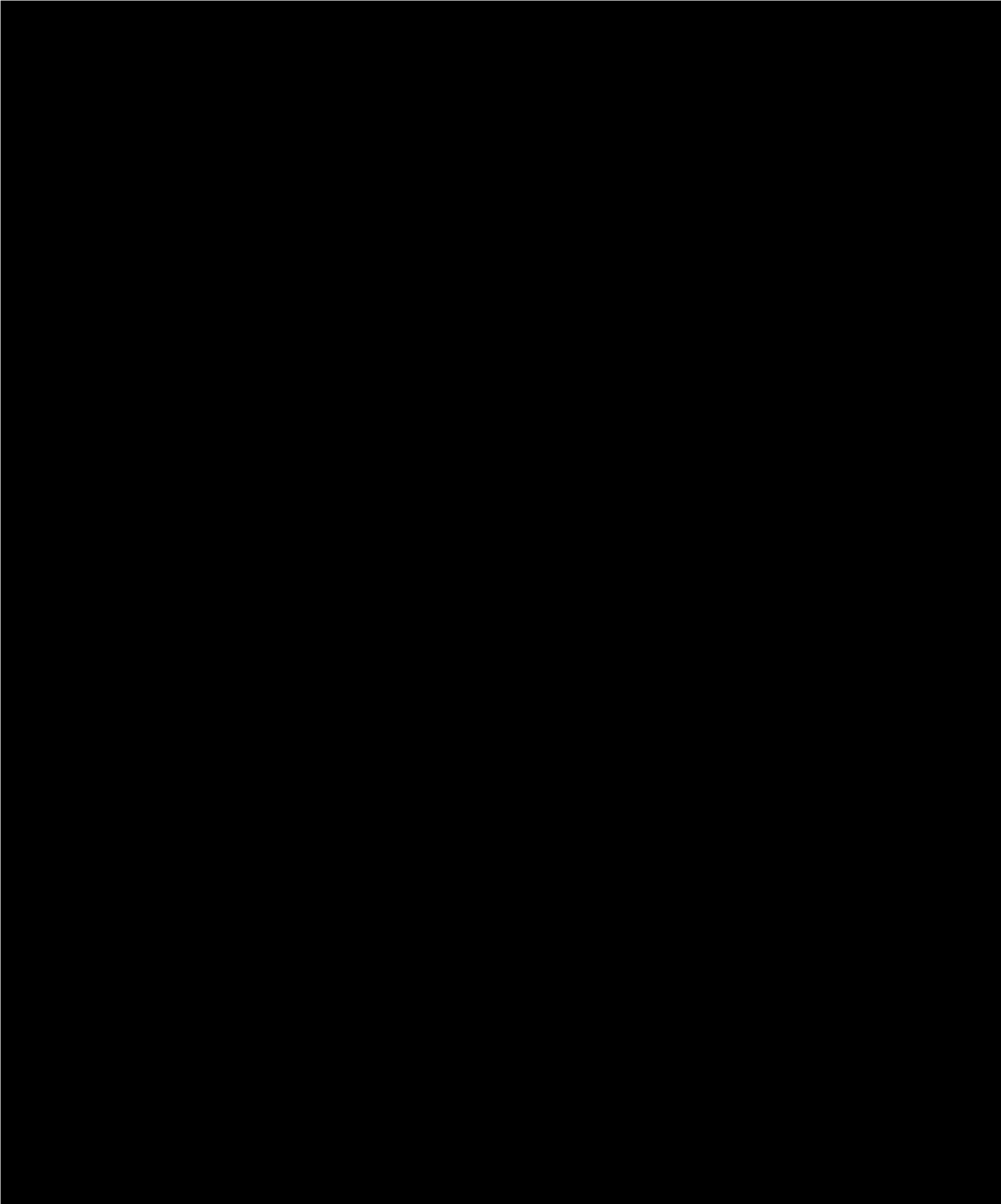

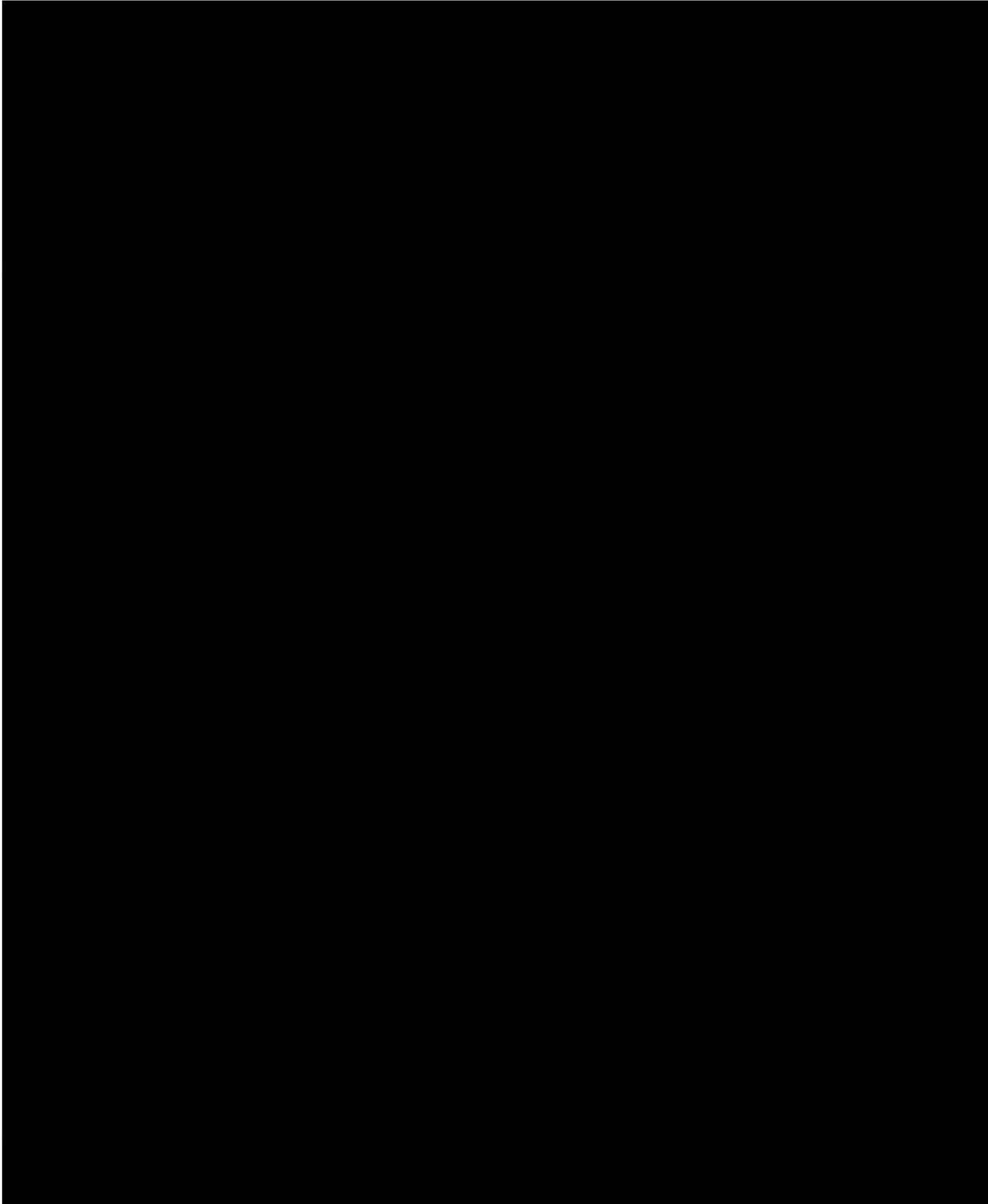

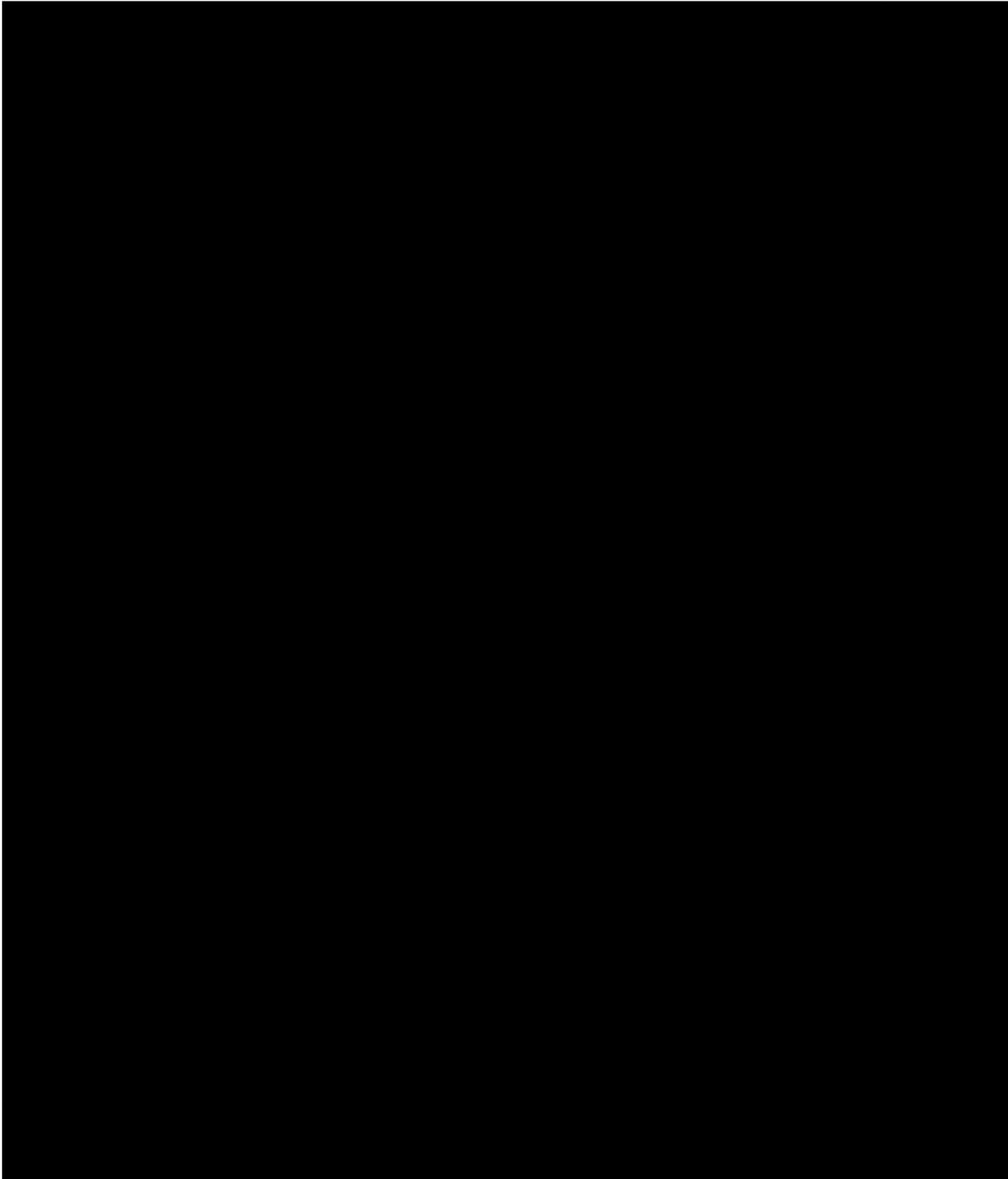

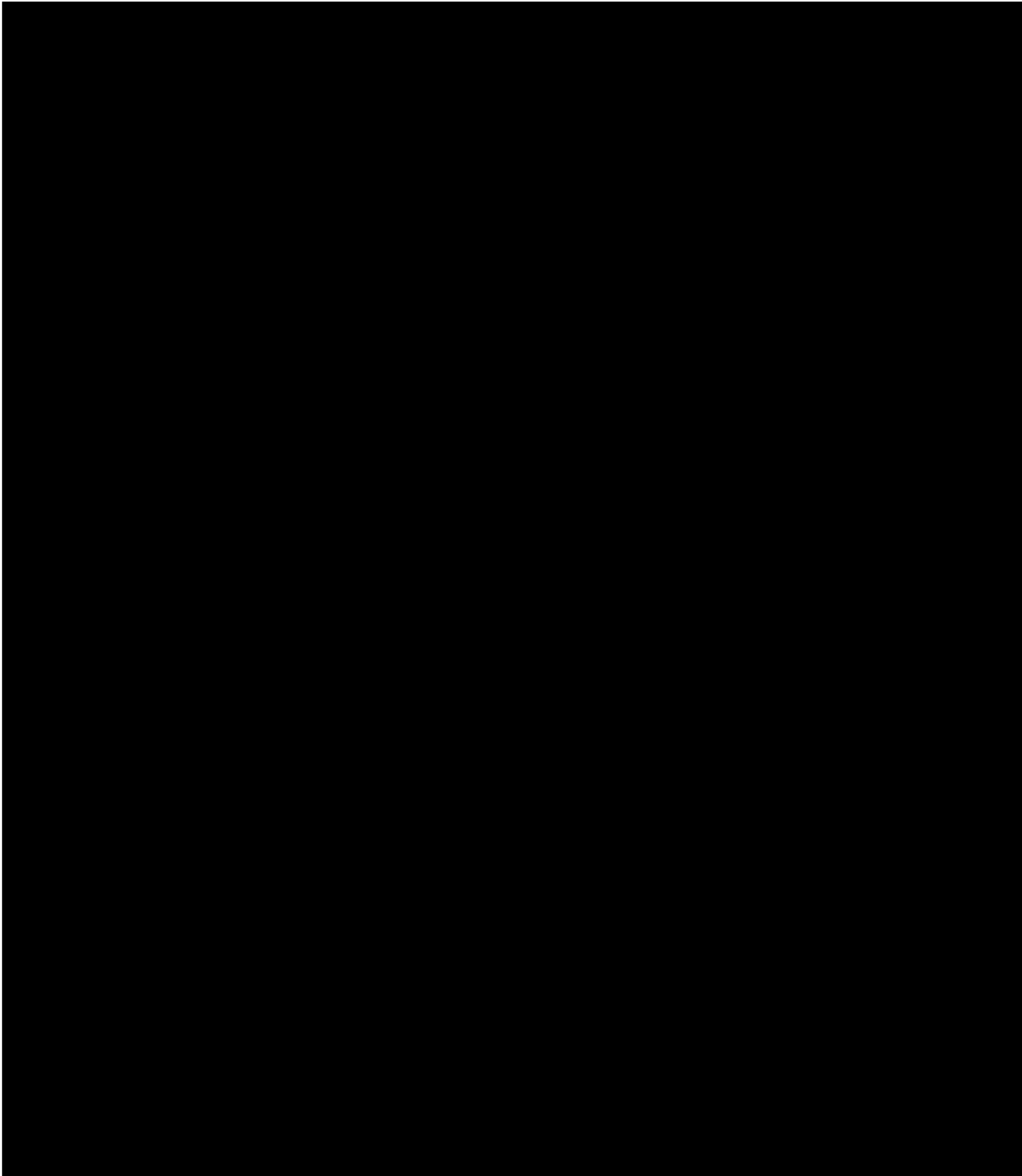

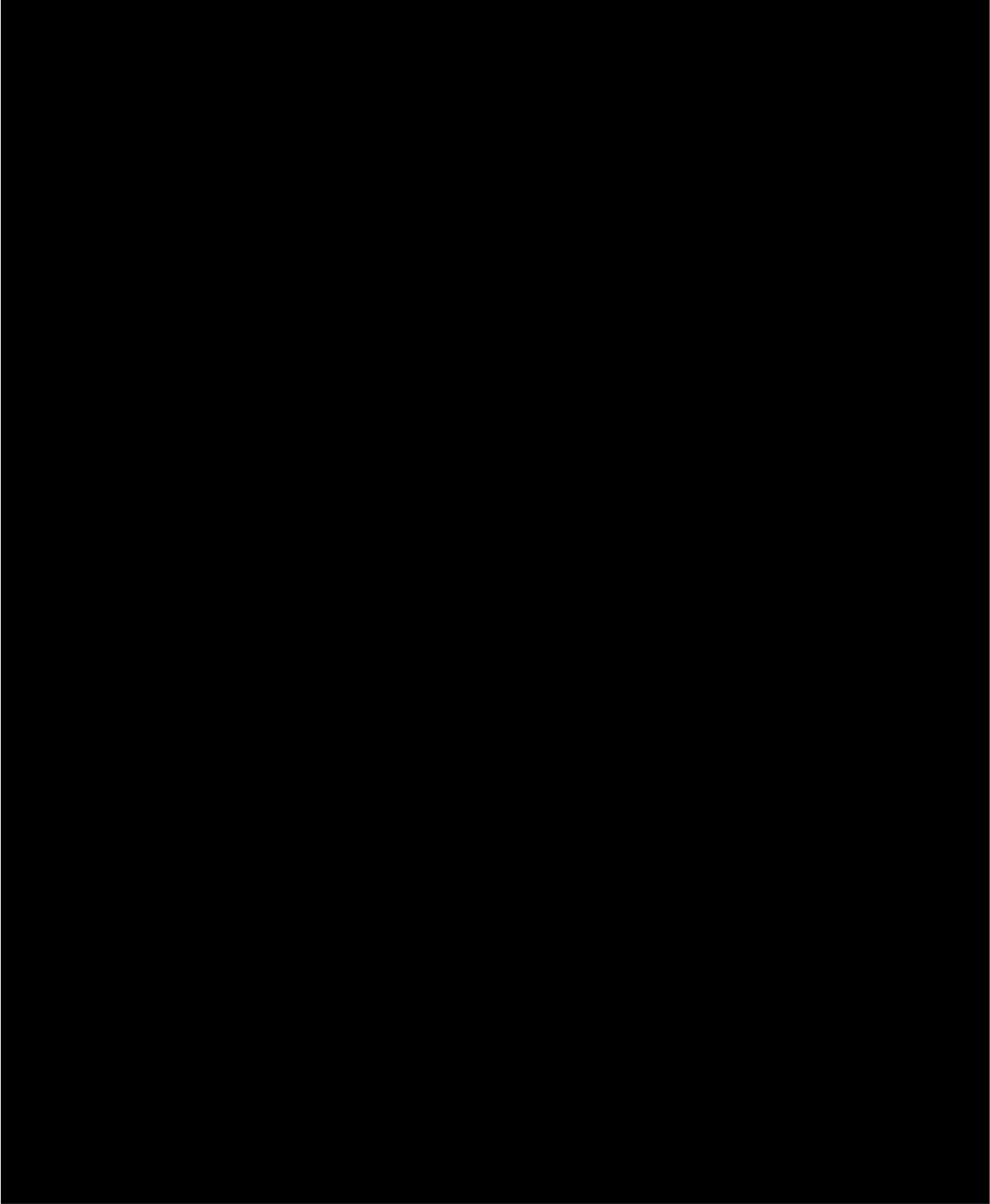

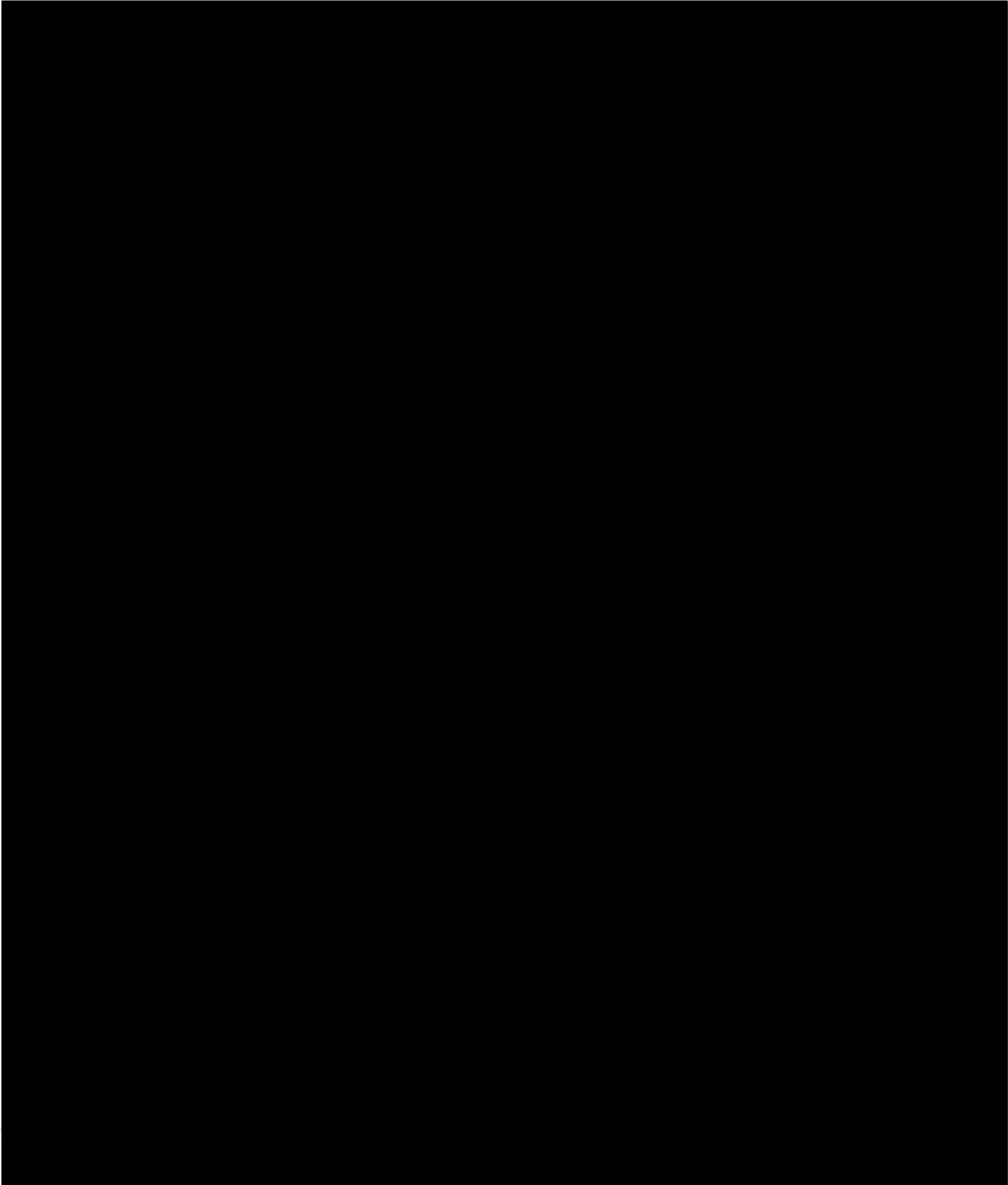

ARTICLE VII

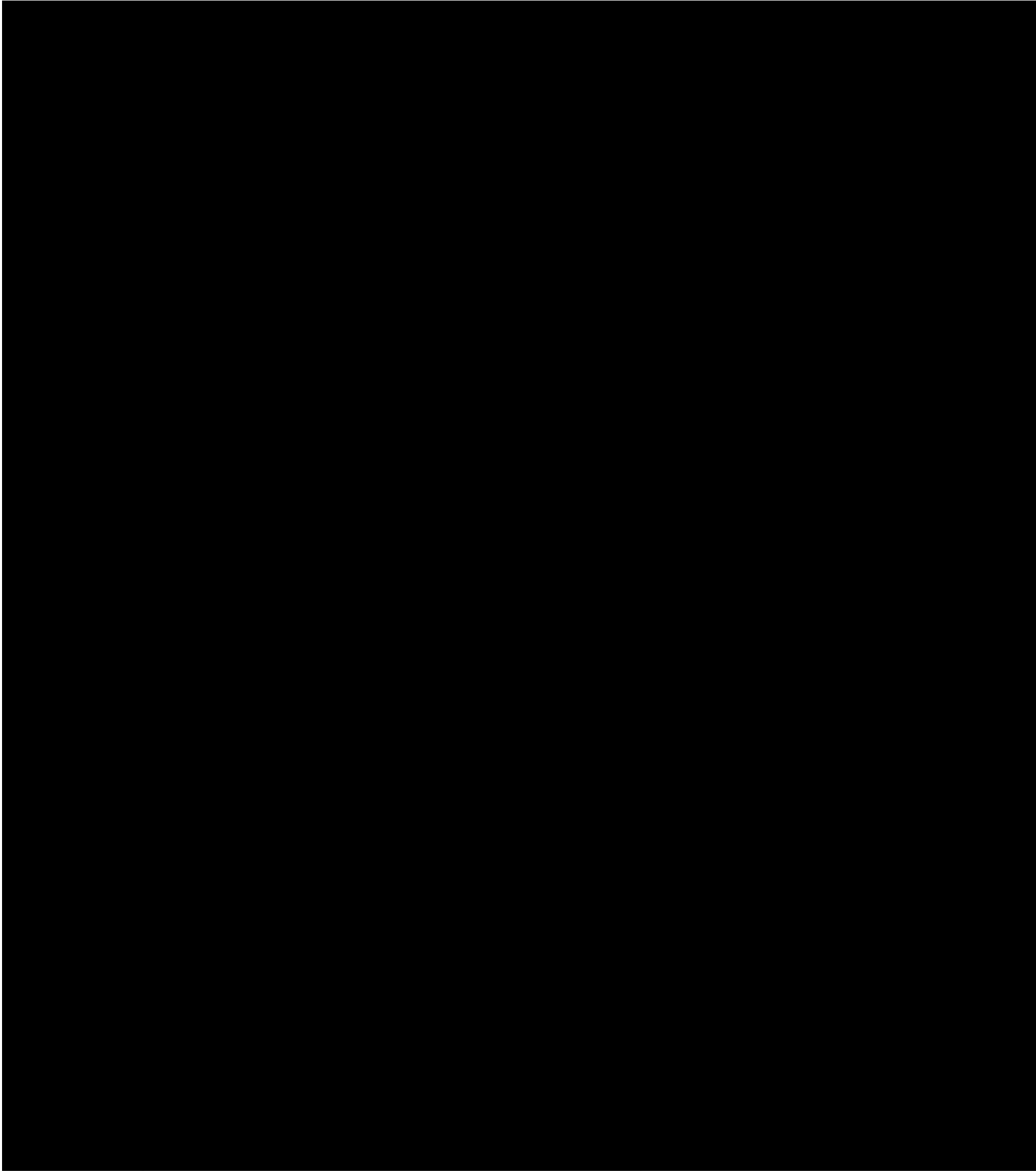

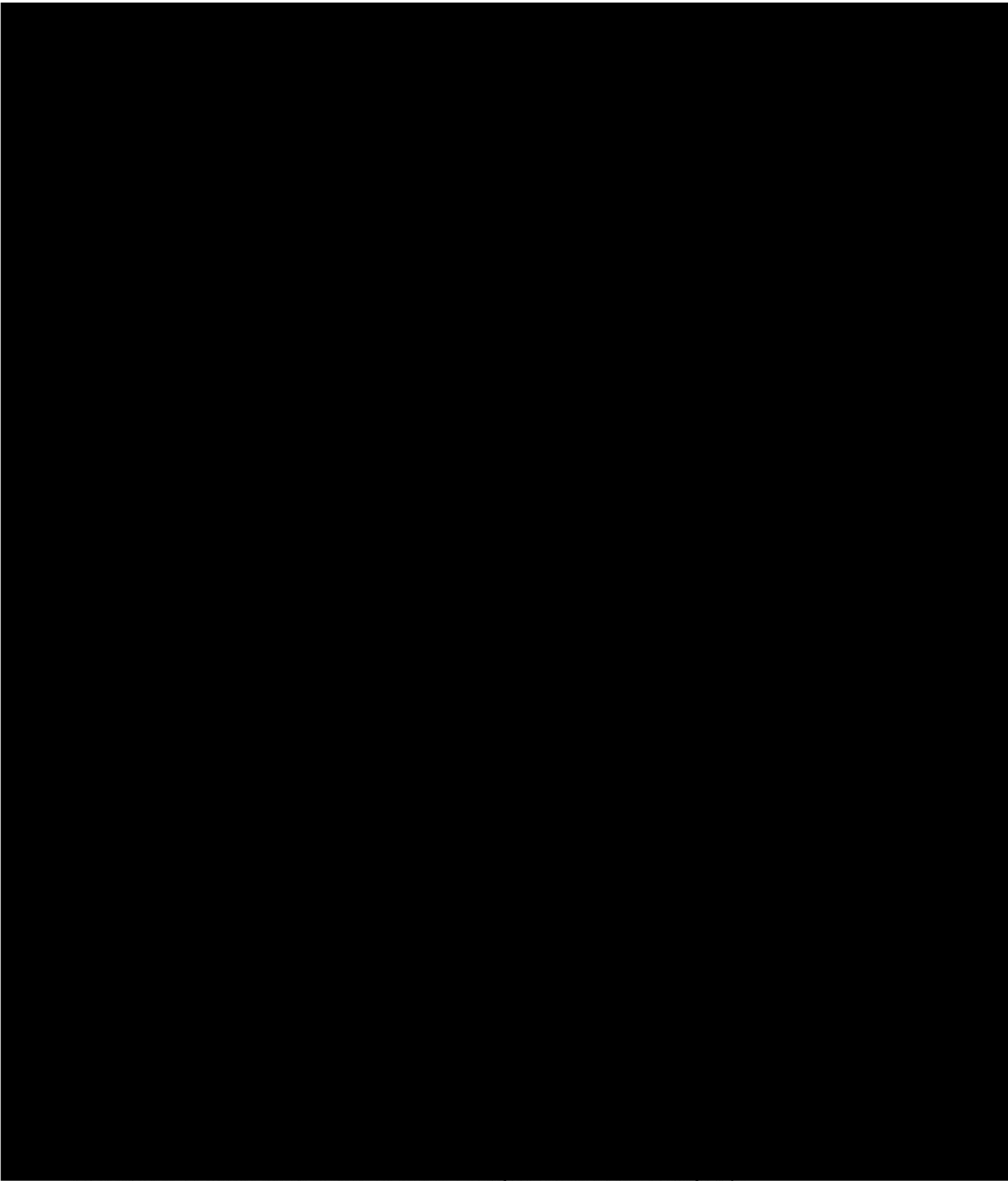

ARTICLE VIII

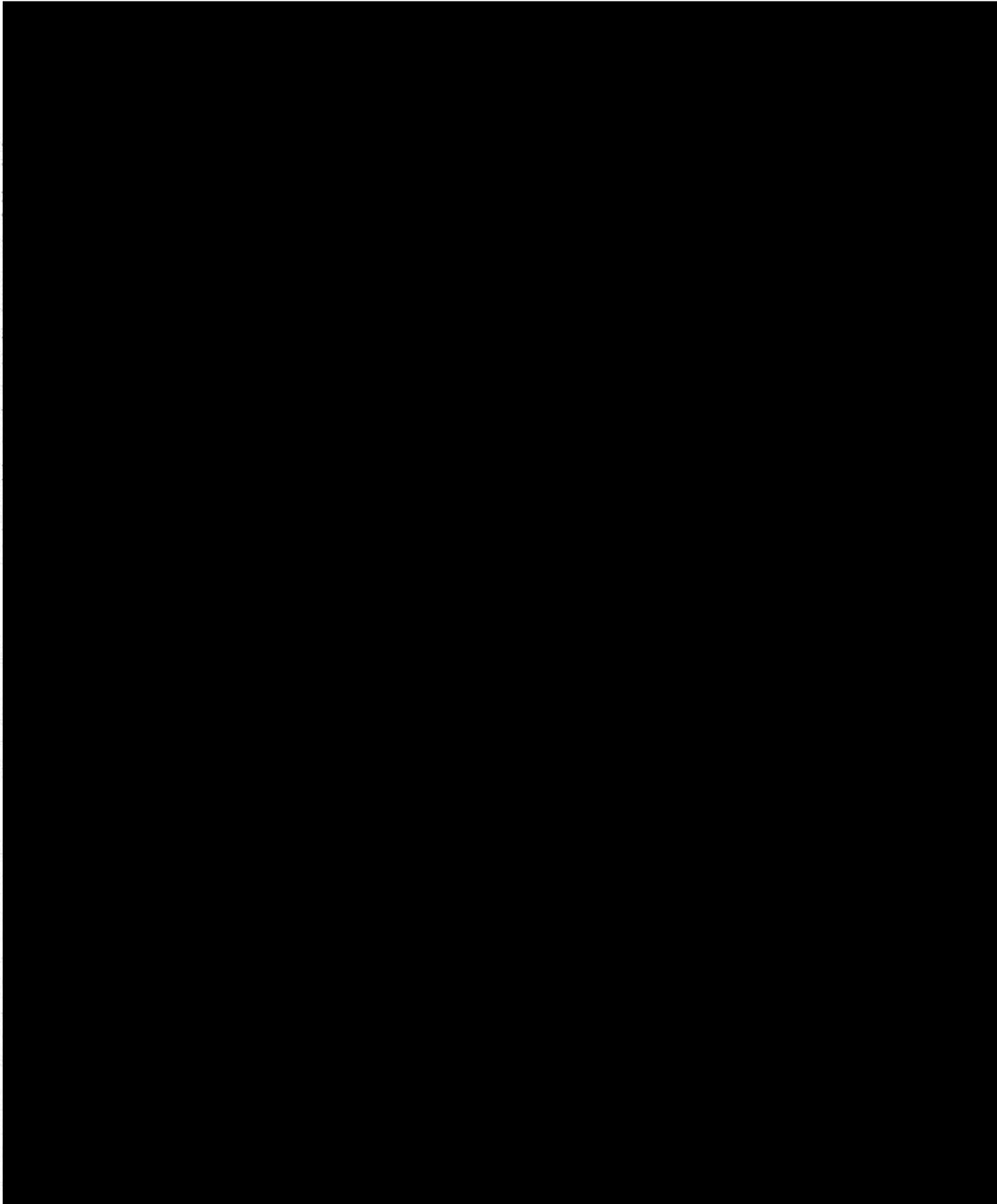

**ARTICLE IX
DISSOLUTION AND WINDING UP**

Section A - Initial Operating Agreement

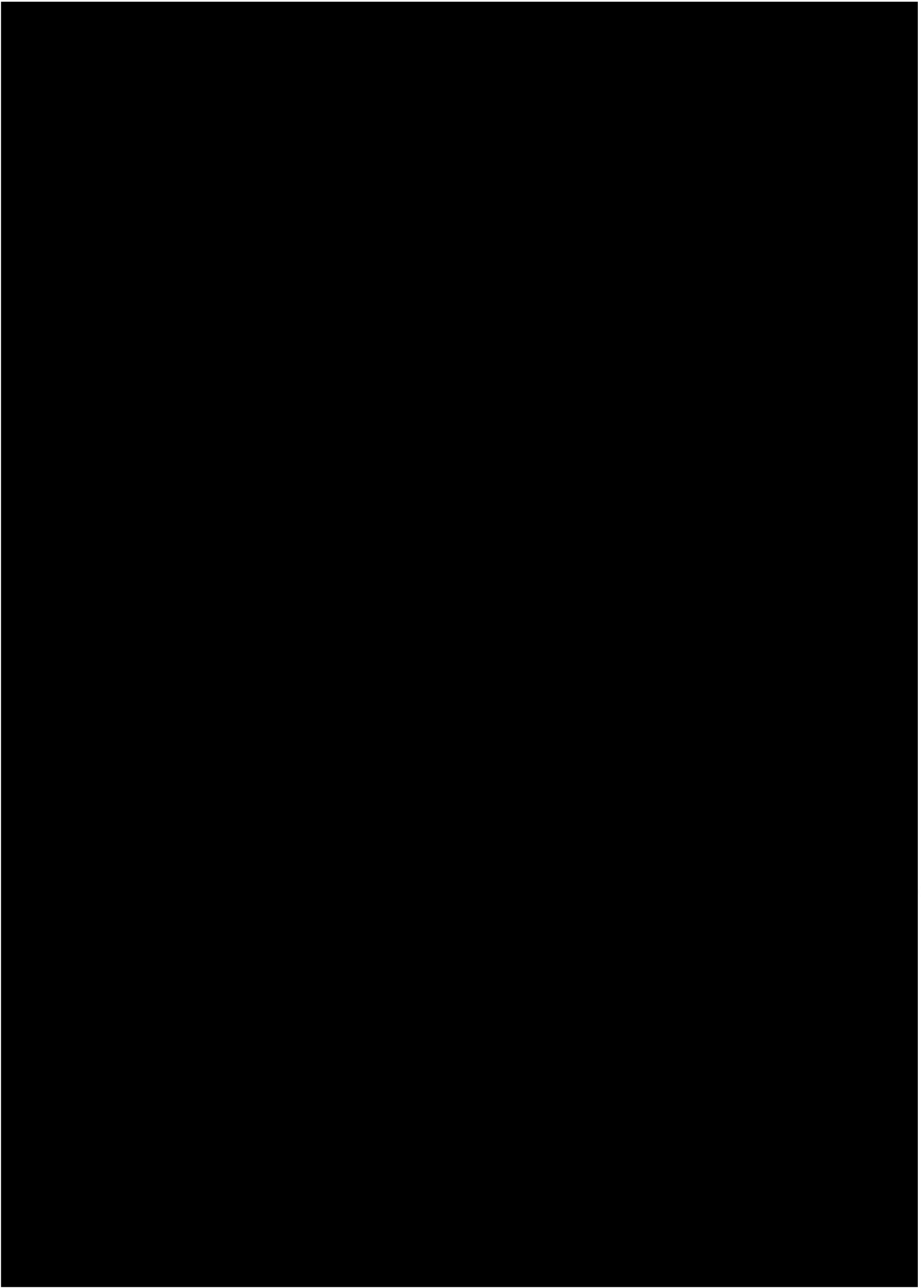

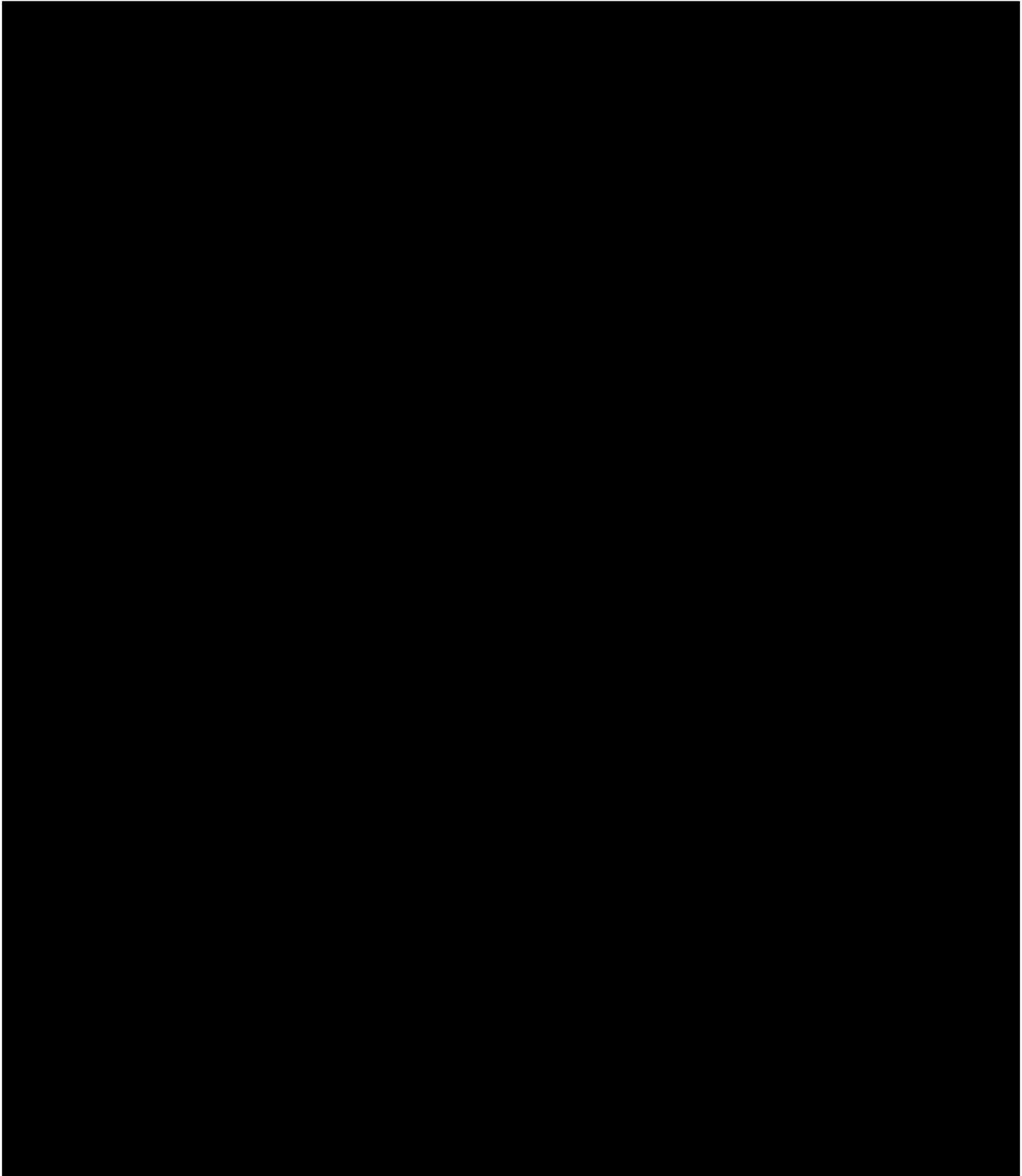

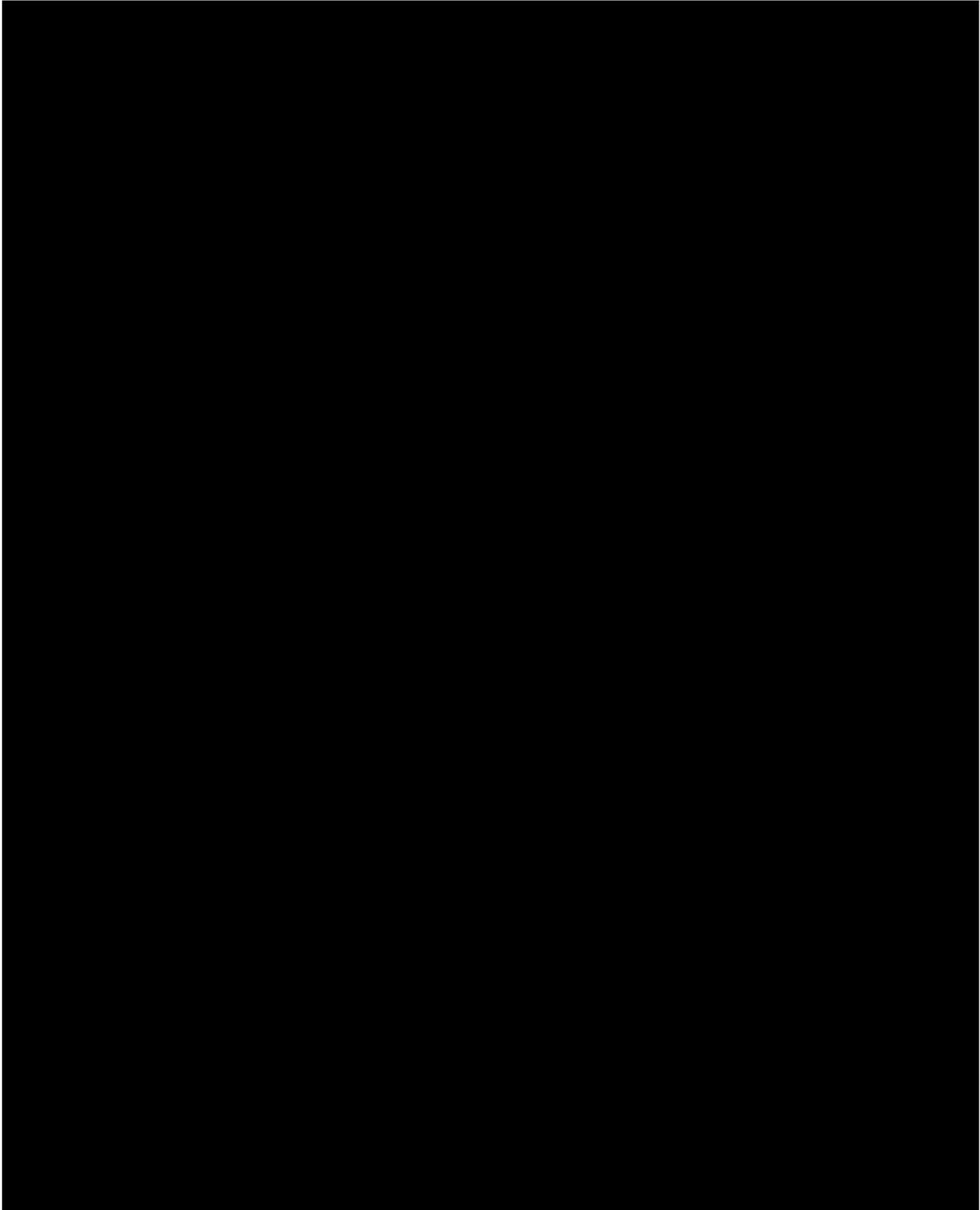

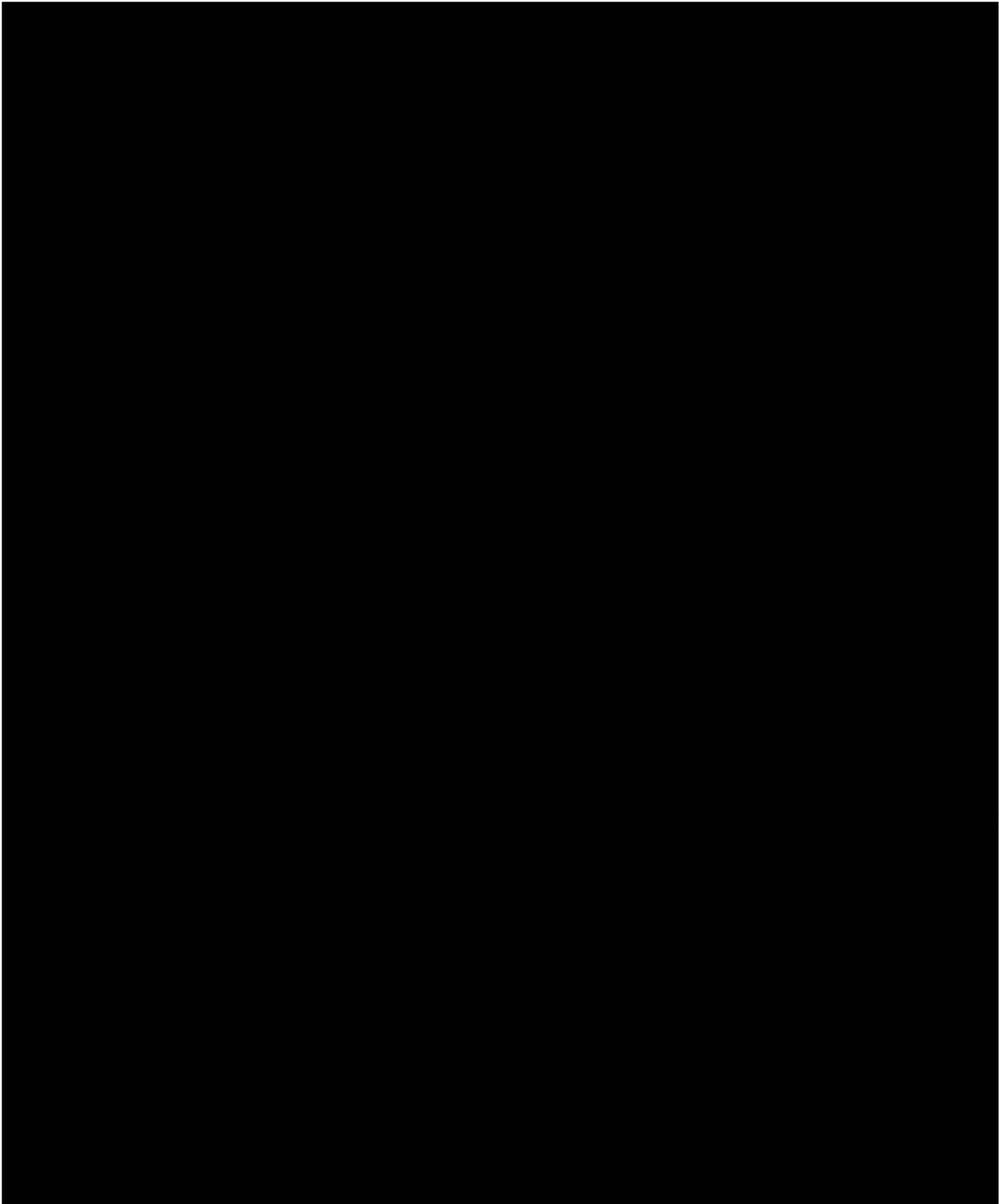

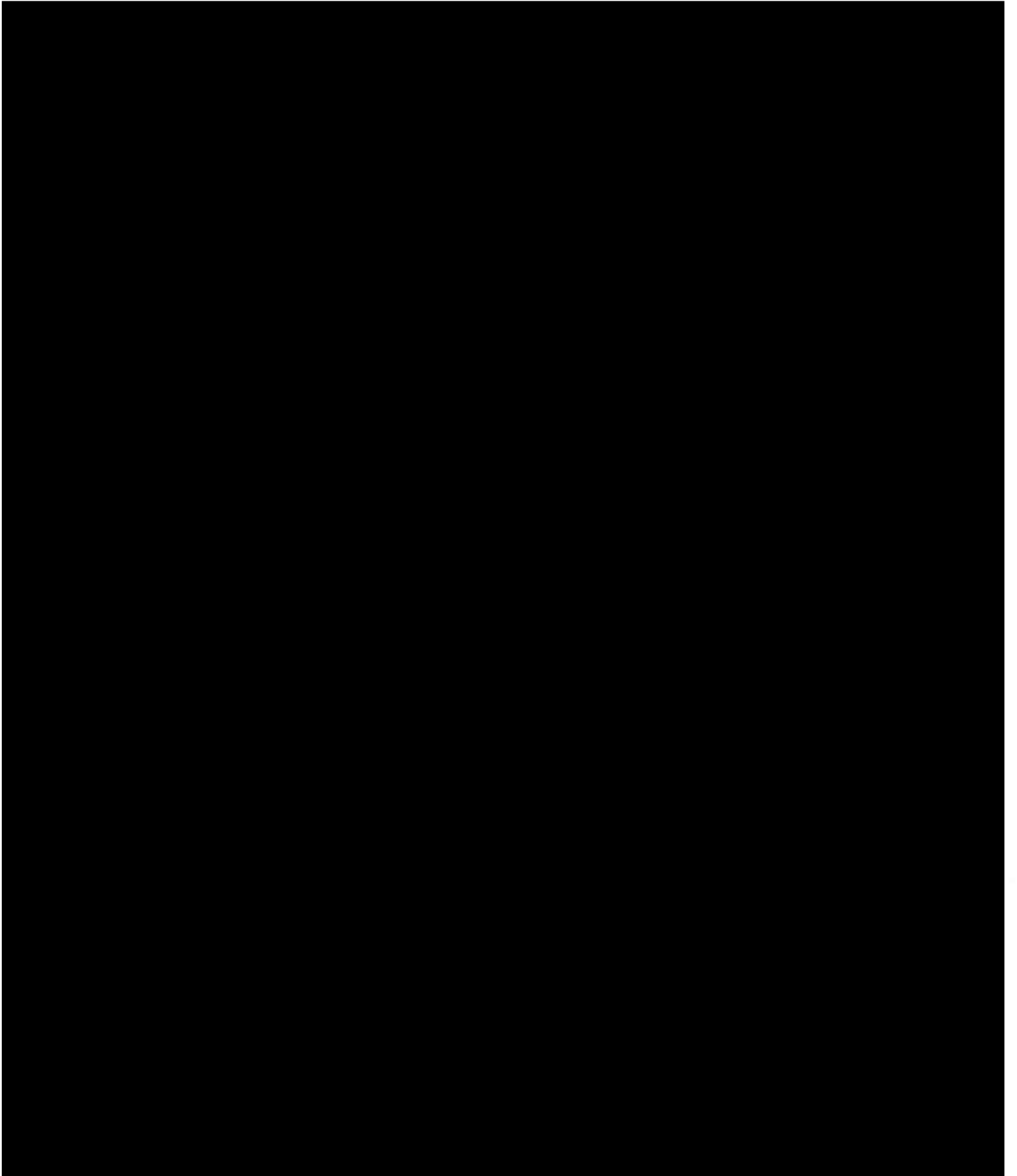

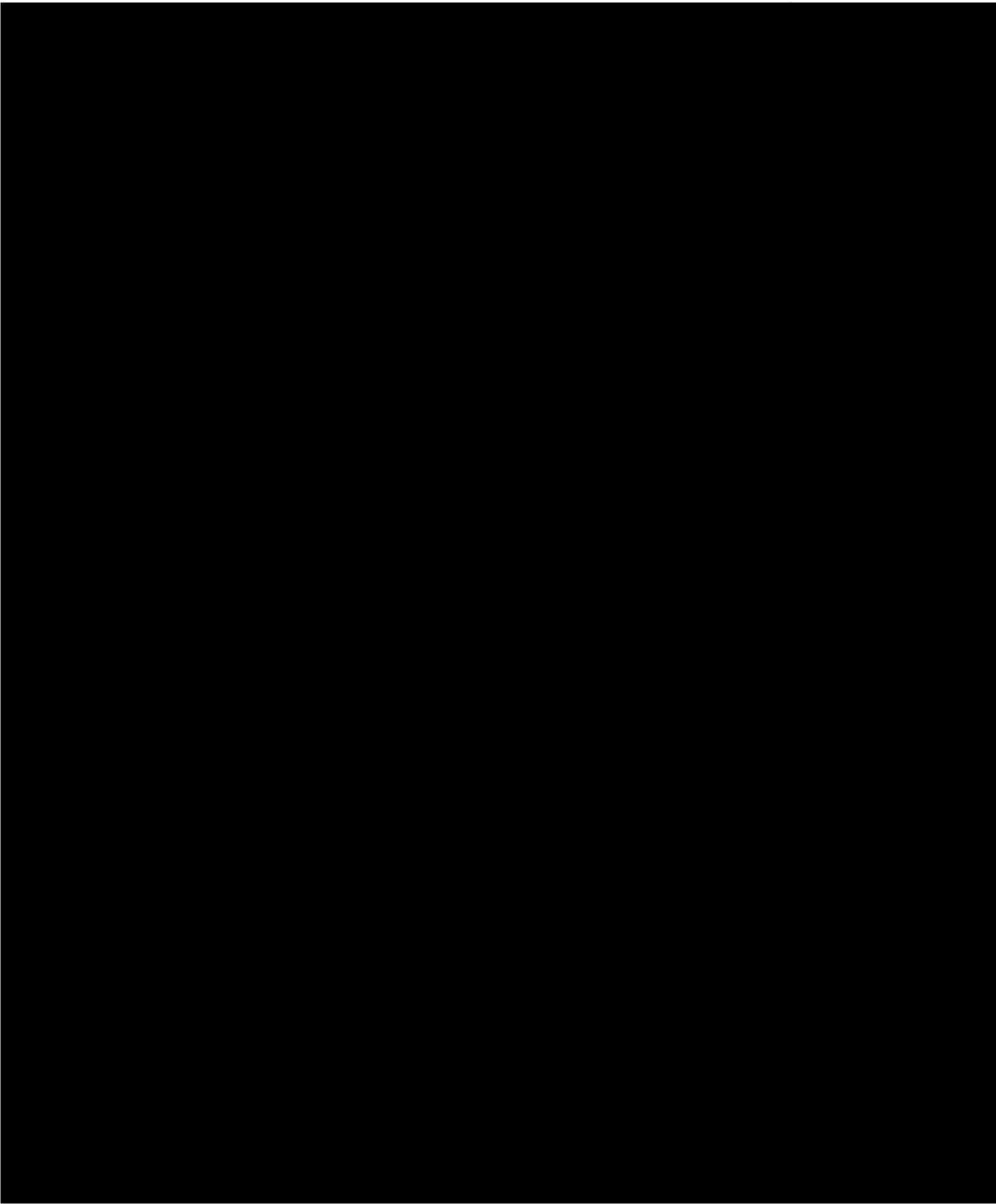



[Signature Pages Follow]

IN WITNESS WHEREOF, the undersigned has executed this Agreement effective as of the Effective Date as set forth above.

MEMBER:



Joseph C. Courtright

MANAGER:



Joseph C. Courtright

Company:

NSMC-OPCO, LLC

By: 

Joseph C. Courtright, Chairman,
CEO, President and Manager

IN WITNESS WHEREOF, the undersigned has executed this Agreement effective as of the Effective Date as set forth above.

MEMBER:



Stephen L. LaFrance, Jr.

IN WITNESS WHEREOF, the undersigned has executed this Agreement effective as of the Effective Date as set forth above.

MEMBER:



Wendy LaFrance

IN WITNESS WHEREOF, the undersigned has executed this Agreement effective as of the Effective Date as set forth above.

MEMBER:

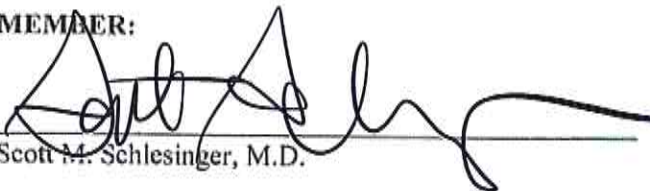

Scott M. Schlesinger, M.D.

IN WITNESS WHEREOF, the undersigned has executed this Agreement effective as of the Effective Date as set forth above.

MEMBER:

A handwritten signature in black ink, appearing to read 'Kelli Schlesinger', written over a horizontal line.

Kelli Schlesinger, M.D.

IN WITNESS WHEREOF, the undersigned has executed this Agreement effective as of the Effective Date as set forth above.

MEMBER:



Cliff Peck

IN WITNESS WHEREOF, the undersigned has executed this Agreement effective as of the Effective Date as set forth above.

MEMBER:



Deane Peck

IN WITNESS WHEREOF, the undersigned has executed this Agreement effective as of the Effective Date as set forth above.

MEMBER:



Robert DeBin

MANAGER:



Robert DeBin

IN WITNESS WHEREOF, the undersigned has executed this Agreement effective as of the Effective Date as set forth above.

MEMBER:



Donna Terrell

MANAGER:



Donna Terrell

IN WITNESS WHEREOF, the undersigned has executed this Agreement effective as of the Effective Date as set forth above.

MEMBER:

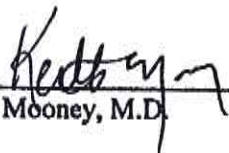

Keith Mooney, M.D.

IN WITNESS WHEREOF, the undersigned has executed this Agreement effective as of the Effective Date as set forth above.

MEMBER:

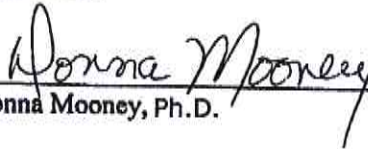

Donna Mooney, Ph.D.

MANAGER:

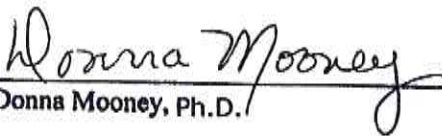

Donna Mooney, Ph.D.

IN WITNESS WHEREOF, the undersigned has executed this Agreement effective as of the Effective Date as set forth above.

MEMBER:

A handwritten signature in black ink, appearing to read 'Alonzo Williams', is written over a horizontal line. The signature is stylized and cursive.

Alonzo Williams, M.D.

IN WITNESS WHEREOF, the undersigned has executed this Agreement effective as of the Effective Date as set forth above.

MEMBER:



Susan Williams

MANAGER:



Susan Williams

Section A - Initial Operating Agreement

EXHIBIT A

to

NSMC-OPCO, LLC OPERATING AGREEMENT

<u>Names of Members</u>	<u>Total Capital Contribution Commitment</u>	<u>No. of Units*</u>	<u>Initial Membership Interests/ Percentage Interests</u>
Joseph C. Courtright			15.7277%
Stephen L. LaFrance, Jr.			5.6620%
Wendy LaFrance			10.0657%
Scott M. Schlesinger, M.D.			5.6620%
Kelli Schlesinger, M.D.			10.0657%
Cliff Peck			4.2254%
Deane Peck			7.5117%
Robert DeBin			4.4601%
Keith Mooney, M.D.			4.2254%
Donna Mooney, M.D.			7.5117%
Alonzo Williams, M.D.			8.4507%
Susan Williams			15.0234%
Donna Terrell			1.4085%
Total			100%

*Assuming all capital contribution commitments of the applicable Member are actually funded and paid by the Member to the Company as provided in this Agreement and the Member's Subscription Agreement with the Company.

APPENDIX
to
NSMC-OPCO, LLC OPERATING AGREEMENT

DEFINITIONS

For purposes of this Agreement, the capitalized terms used in this Agreement (including this Appendix) shall have the following meanings, unless the context otherwise specifically requires:

"Act" shall mean and refer to Act 1003 of 1993 of the Arkansas General Assembly (Ark. Code Ann. § 4-32-101 et seq.), as amended.

"Affiliate" shall mean any Person directly or indirectly controlling, controlled by, or under common control with the other Person in question. As used in this definition of "Affiliate," the term "control" means the possession, directly or indirectly, of the power to direct or cause the direction of the management and policies of a Person, whether through the ownership of voting securities, by contract, or otherwise.

"Agreement" shall mean and refer to this Operating Agreement, and all amendments hereto.

"Appendix" shall mean this Appendix.

"Articles of Organization" shall mean and refer to the Articles of Organization of the Company filed with the Arkansas Secretary of State, as properly amended from time to time.

"Assignee" shall mean and refer to a transferee of a Membership Interest who has not been admitted as a Member.

"Board" shall have the meaning set forth in **Section 3.1**.

"Business Day" shall mean and refer to any day other than a Saturday, Sunday or legal holiday observed in the State of Arkansas.

"Capital Account" means, with respect to each Member, the capital account of the applicable Member or Members maintained in the Company's books and records in accordance with this Agreement, the Code and Regulations.

"Cause" shall mean embezzlement, fraud, material intentional breach of duty to the Company, gross negligence, willful misconduct, intentional breach of this Agreement, or material failure, within ten (10) days after written notice, to fulfill the Person's obligations or commitments to the Company as provided in this Agreement or the Member's Subscription Agreement with the Company; or any other occurrence or event with respect to the Member which would, or could reasonably be expected to, render the Member ineligible to continue to own an ownership interest in the Company under any applicable material governmental license

or permit held (or expected to be held) by the Company under applicable law or governmental agency rule or regulation, or which would, or could reasonably be expected to, have a material adverse effect, or place in jeopardy, any such material governmental license or permit, or any renewal thereof.

"Code" shall mean and refer to the Internal Revenue Code of 1986, as amended.

"Company" shall mean and refer to NSMC-OPCO, LLC, the Arkansas limited liability company formed pursuant to the Articles of Organization.

"Company Property" or **"Property"** shall mean any property owned by the Company, and shall include both tangible and intangible property.

"Disposition" or "Dispose" shall mean and refer to any sale, exchange, assignment, gift, mortgage, pledge, grant, hypothecation or other transfer or conveyance, either voluntarily or involuntarily, by judicial order, operation of law or otherwise. With respect to any Member that is not a natural person, a direct or indirect change (determined from the date the Member first became a Member of the Company) of more than fifty percent (50%) in the equity or voting interests in the Member or power to direct or cause the direction, directly or indirectly, of the management and policies of the Member, whether through the ownership of voting securities, by contract, or otherwise, shall be deemed to constitute a Disposition of the Member's Membership Interest in the Company for purposes of this Agreement, unless such change was to a Permitted Transferee of the Member.

"Dissociated Member" shall mean and refer to any Member who ceases to be a Member in the Company by reason of the occurrence of an Event of Dissociation with respect to such Member as provided herein.

"Dissociation" or **"Event of Dissociation"** shall mean and refer to any event or other action that causes a Member to cease to be a Member as provided herein.

"Effective Date" shall mean and refer to September 4, 2017. This Agreement shall be effective on and as of said Effective Date.

"Event of Dissolution" shall mean and refer to any event, the occurrence of which will result in the dissolution of the Company as provided in this Agreement, unless the Members otherwise vote or consent to the contrary as provided herein.

"Fair Market Value" shall mean and refer to the price at which the property in question would change hands between a willing buyer and willing seller, neither under any compulsion to buy or sell, and both having reasonable knowledge of the relevant facts; provided, for purposes of determining the Fair Market Value of a Membership Interest in the Company, the Fair Market Value of the Membership Interest shall be equal to the amount that would be received by the Member owning such Membership Interest if the Company sold all of its assets at Fair Market Value in a commercially reasonable manner, paid all of its liabilities (including any reasonable reserve for any bona fide contingent liability), and then dissolved and liquidated as otherwise

provided in this Agreement. In the event it becomes necessary to determine the Fair Market Value of any property, the Fair Market Value of the property shall be determined by agreement of the parties involved, or in the absence of such agreement, by an independent individual appraiser or appraisal firm mutually acceptable to such parties. In the event the parties involved are unable to agree on an individual appraiser or firm to perform the valuation, each party shall select a qualified independent appraiser, and such appraisers shall first attempt to jointly determine the Fair Market Value of the property by mutual agreement, but if they are unable to agree on such valuation, such appraisers shall select a third qualified independent appraiser, and the Fair Market Value shall be determined by the average of the two appraisals with the closest valuations. If the two appraisers cannot agree on a third appraiser, the third appraiser shall be selected by an arbitrator appointed pursuant to the rules of the American Arbitration Association or its successor. Any valuation so determined shall be binding and conclusive on the parties, absent manifest error. The cost of any such appraisal performed by a single appraiser mutually selected by the parties shall be borne equally by the seller and the purchaser. If two appraisers are required, each party shall bear the cost of the appraiser selected by the party; and if a third appraiser is required, the cost of such third appraisal shall be borne by the party whose appraiser's appraisal (or if applicable, whose last written proposal, delivered to the other party before the third appraiser was engaged), is the further from the third appraiser's valuation, as measured by the difference in dollars.

"Family Member" shall mean with respect to any Person, such Person's spouse, ancestor, sibling, or descendant, or any ancestor, sibling or descendant of such Person's spouse.

"Fiscal Year" shall mean the Company's taxable year for federal income tax purposes.

"Formation Date" shall mean and refer to the date on which the original Articles of Organization of the Company were filed with the Arkansas Secretary of State (i.e., August 3, 2017).

"Ineligible Transferee" shall mean any transferee who would, or could reasonably be expected to, not be eligible to own an ownership interest in the Company under any applicable material governmental license or permit held (or expected to be held) by the Company under applicable law or governmental agency rule or regulation, or whose ownership of a Membership Interest in the Company would, or could reasonably be expected to, have a material adverse effect, or place in jeopardy, any such material governmental license or permit, or any renewal thereof, in each case as reasonably determined by the Board.

"Manager(s)" shall have the meaning set forth in **Section 3.1**.

"Majority in Interest of the Members" shall mean any Member (or group of Members), whose Percentage Interest(s) exceed(s) fifty percent (50%), individually or in the aggregate.

"Majority in Interest of the Other Members" shall mean any such other Member (or group of such other Members) whose Percentage Interest(s) exceed(s) fifty percent (50%) of the Percentage Interests of all such other Members, individually or in the aggregate.

"Majority in Interest of the Remaining Members" shall mean any Remaining Member (or group of Remaining Members) whose Percentage Interest(s) exceed(s) fifty percent (50%) of the Percentage Interests of all Remaining Members, individually or in the aggregate.

"Members" shall mean and refer to the persons listed as such on **Exhibit A** attached hereto, and such other persons hereafter admitted to the Company as Members in accordance with the terms of this Agreement. The term "Member" shall mean and refer to any of the Members, individually, as the context requires. A Manager shall be deemed a Member with respect to the Manager's ownership of any Membership Interest in the Company.

"Membership Interest" or **"Interest"** shall mean and refer to a Member's entire ownership interest and rights in the Company as a Member. Membership Interests may be represented by units which are evidenced by certificates of interest ("**Units**").

"Non-Fully Funding Member" shall mean any Member that does not fully fund the Member's pro rata share of any request for additional capital by the Company as set forth herein.

"Percentage Interest(s)" shall mean and refer to each respective Member's ownership interest in the Company expressed as a percentage. If Membership Interests are represented by units ("**Units**"), this ratio shall be determined by dividing (i) the number of Units owned by the Member by (ii) the total number of Units issued and outstanding. The initial Percentage Interest for each Member is set forth opposite such Member's name on **Exhibit A** attached hereto.

"Permitted Transferee" of a Member shall mean and refer to (i) any current spouse or lineal descendant of the Member; (ii) any trust for the primary benefit of the Member or any current spouse or lineal descendant of the Member; or (iii) any corporation, partnership, limited liability company, limited partnership or other entity controlled by or under common control with the Member and/or any one or more of the Member's Permitted Transferees; provided, however, notwithstanding anything herein to the contrary, a Permitted Transferee shall not include any Ineligible Transferee. As used in this definition, the term "control" means the possession, directly or indirectly, of the power to direct or cause the direction of the management and policies of the corporation, partnership, limited liability company, limited partnership or other entity, whether through the ownership of voting securities, by contract, or otherwise.

"Person" shall mean any natural person, corporation, partnership, limited liability company, trust or other entity.

"Profits and Losses" means, for each Fiscal Year or other period for which Profits and Losses must be computed, the Company's taxable income or loss determined in accordance with Code Section 703(a), adjusted as follows:

(a) taxable income or loss shall include all items of income, gain, loss, or deduction which Code Section 703(a)(1) requires to be stated separately;

(b) Profits or Losses shall include any tax-exempt income of the Company not otherwise taken into account in computing Profits or Losses;

(c) Profits or Losses shall include Company expenditures which are described in Code Section 705(a)(2)(B) (or treated as such pursuant to Regulation Section 1.704-1(b)(2)(iv)(b)) and which are not otherwise taken into account in computing Profits or Losses; and

(d) if applicable, gain or loss resulting from any taxable disposition of Company Property shall be computed by reference to the Property's adjusted value, if any, as required by this Agreement, the Code or Regulations, rather than by reference to the Property's adjusted basis for federal income tax purposes.

"Regulation(s)" shall mean and refer to such applicable U.S. Treasury Department (and/or Internal Revenue Service) rules and regulations, as amended, which are promulgated and in effect from time to time under or pursuant to the Code.

"Remaining Members" shall mean and refer to the Members who would be remaining after the occurrence of an Event of Dissociation with respect to another Member or Members. The term "Remaining Member" shall mean and refer to any of the Remaining Members, individually, as the context requires.

"Subscription Agreement" shall mean with respect to a Member, the Member's Subscription Agreement for Units of Membership Interest in the Company executed by and between the Member and the Company.

"Super Majority in Interest of the Members" shall mean any Member (or group of Members), whose Percentage Interest(s) exceed(s) sixty-seven percent (67%), individually or in the aggregate.

"Super Majority in Interest of the Remaining Members" shall mean any Remaining Member (or group of Remaining Members), whose Percentage Interest(s) exceed(s) sixty-seven percent (67%), individually or in the aggregate of such Remaining Members.

SUBSCRIPTION AGREEMENT

NSMC-OPCO, LLC

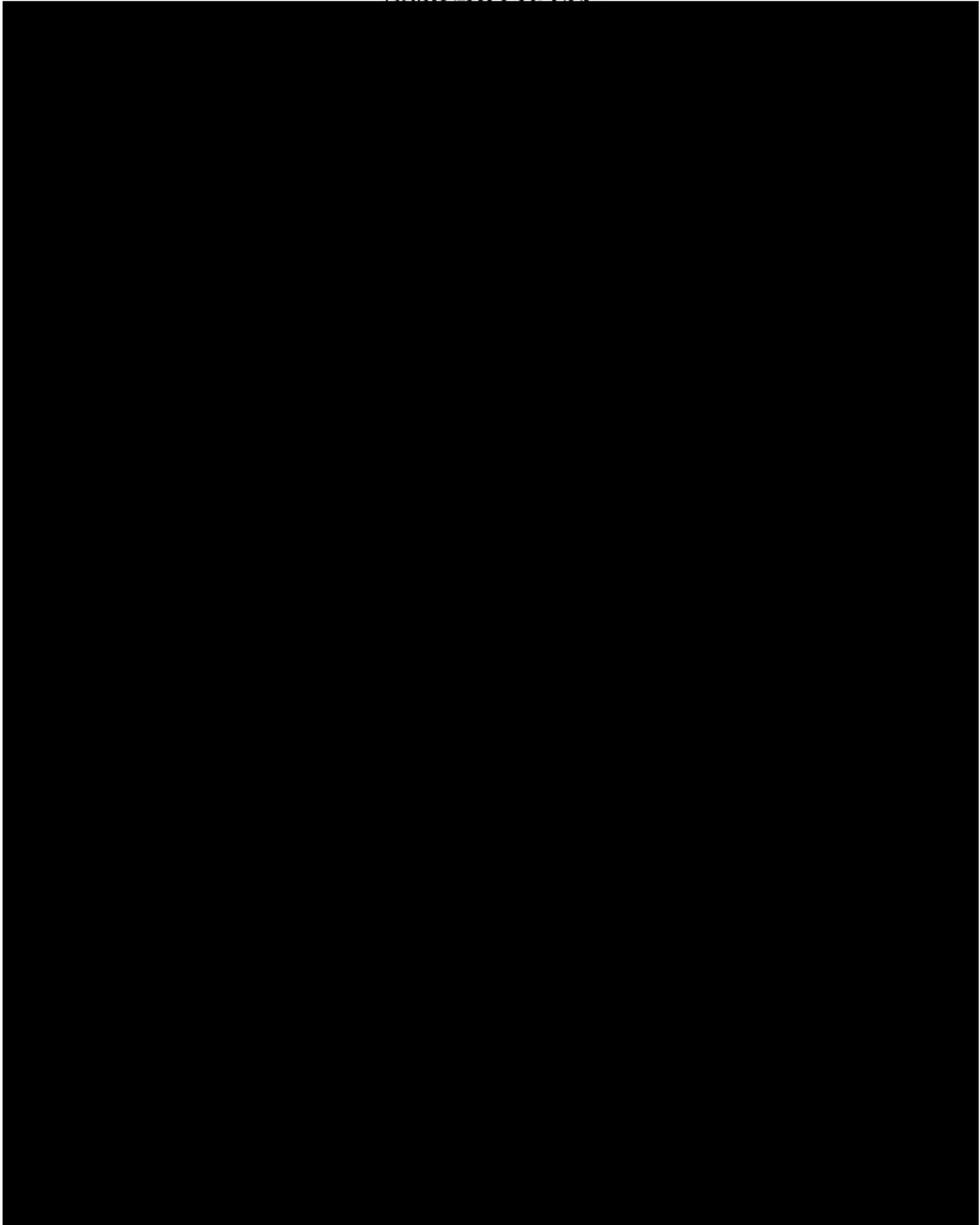

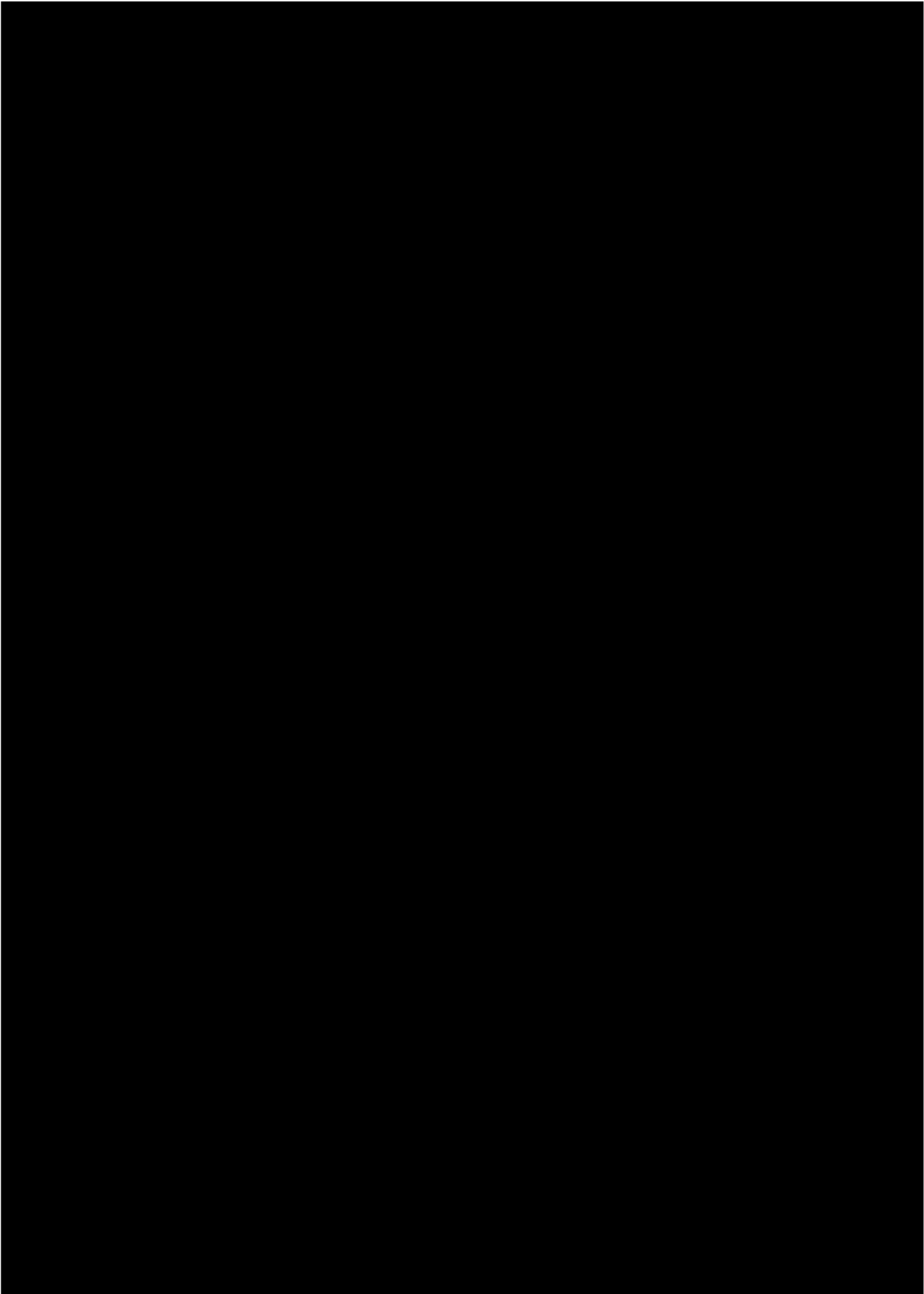

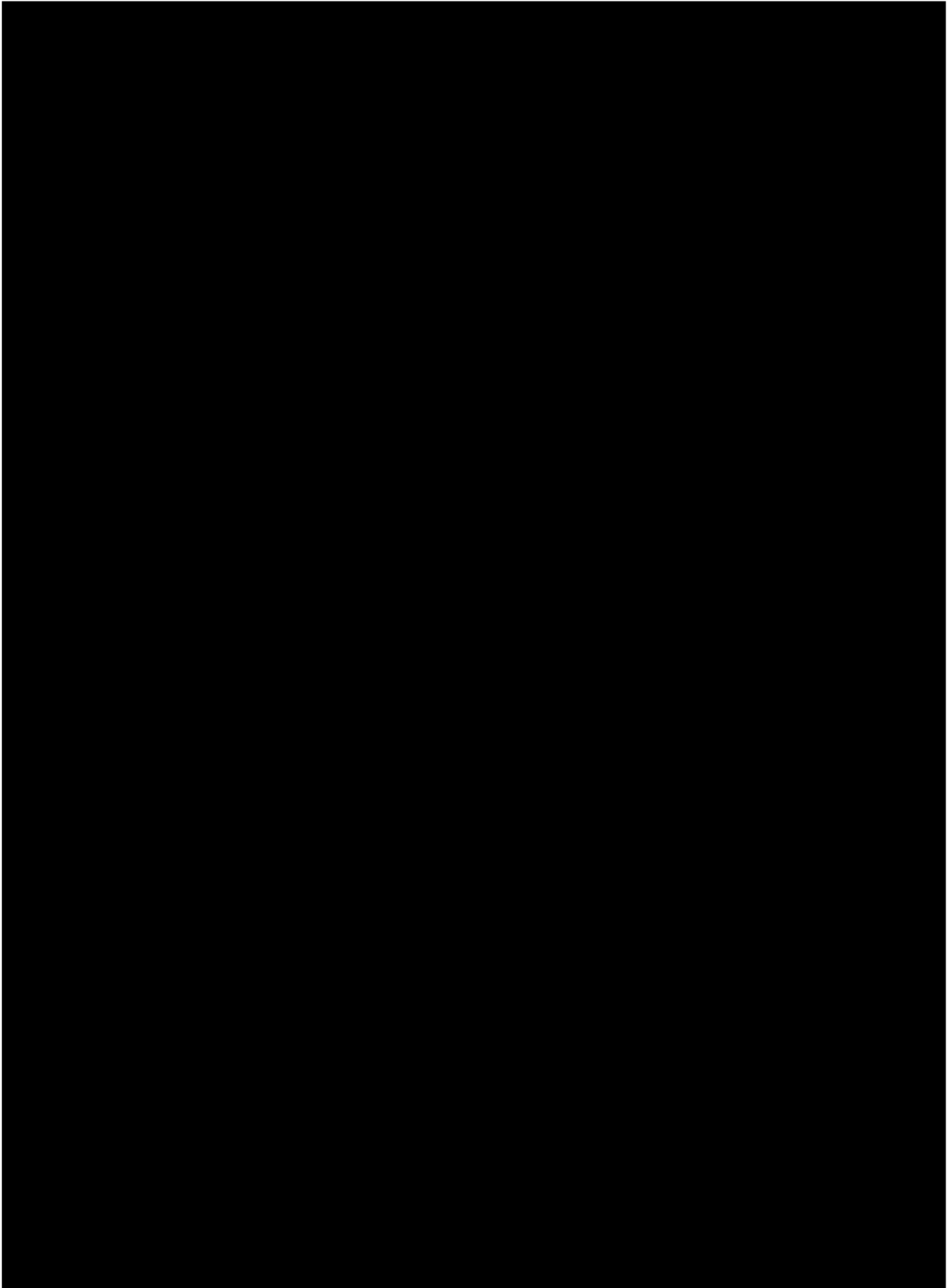

Section A - Subscription Agreement

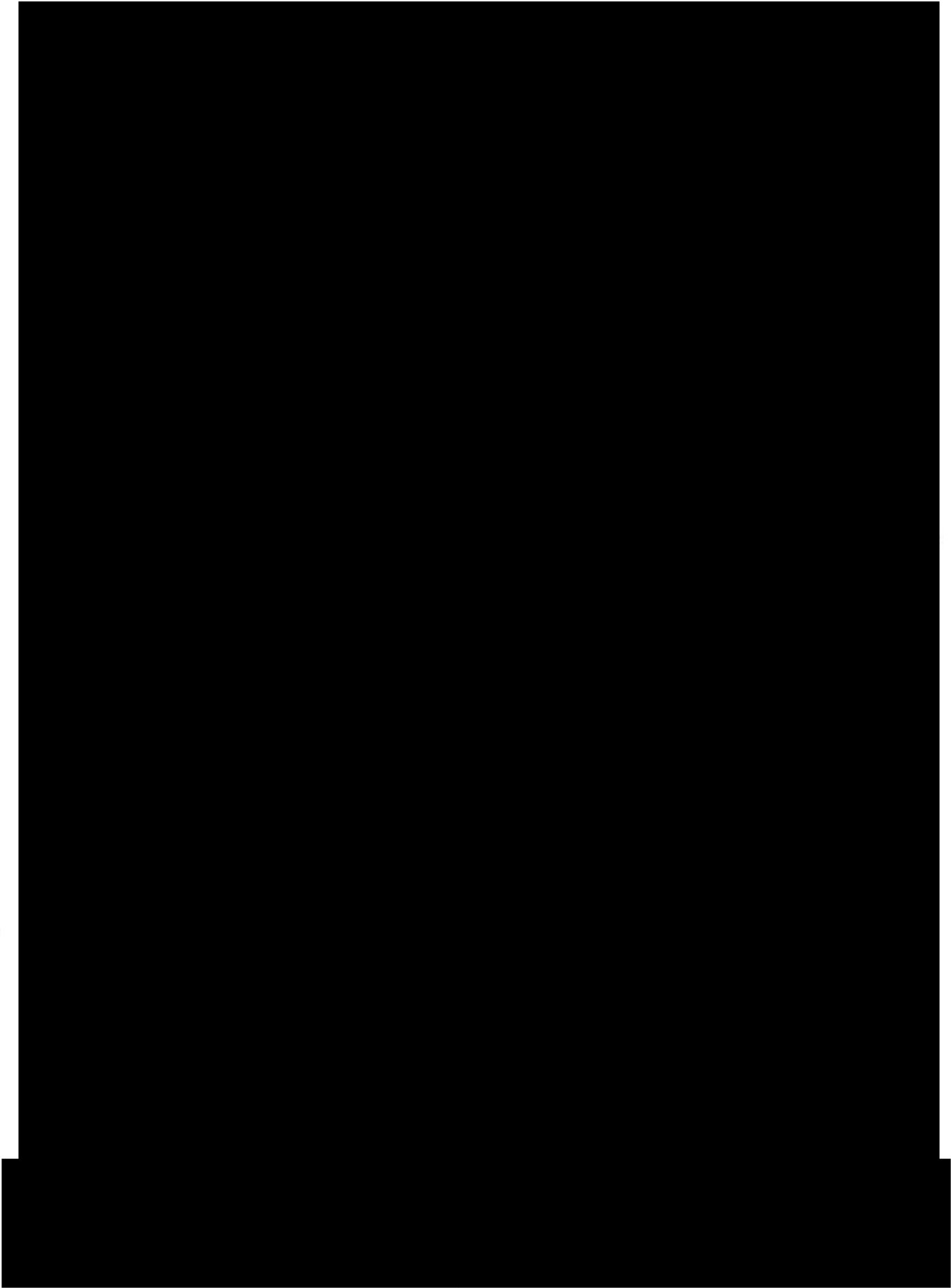

Section A - Subscription Agreement

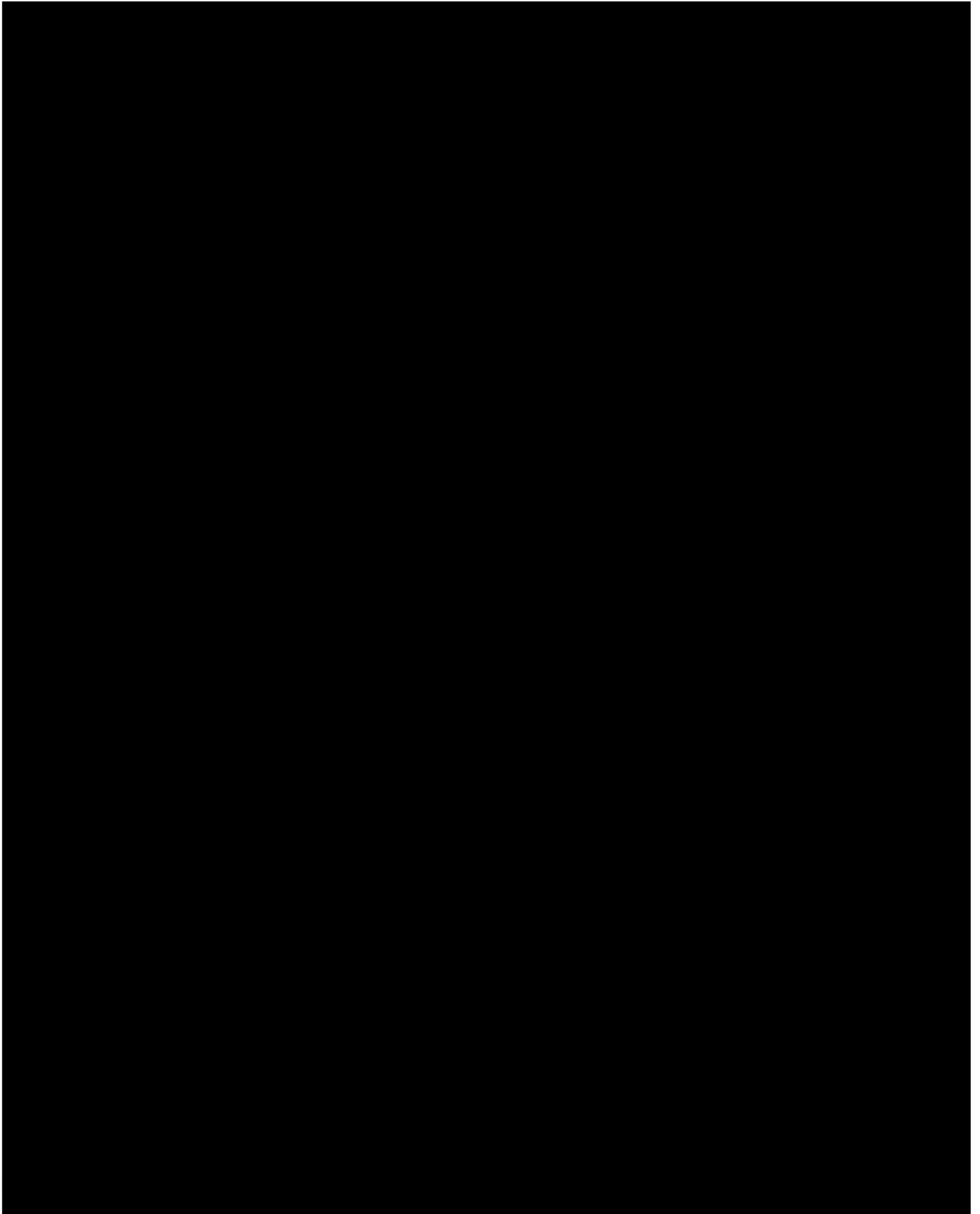

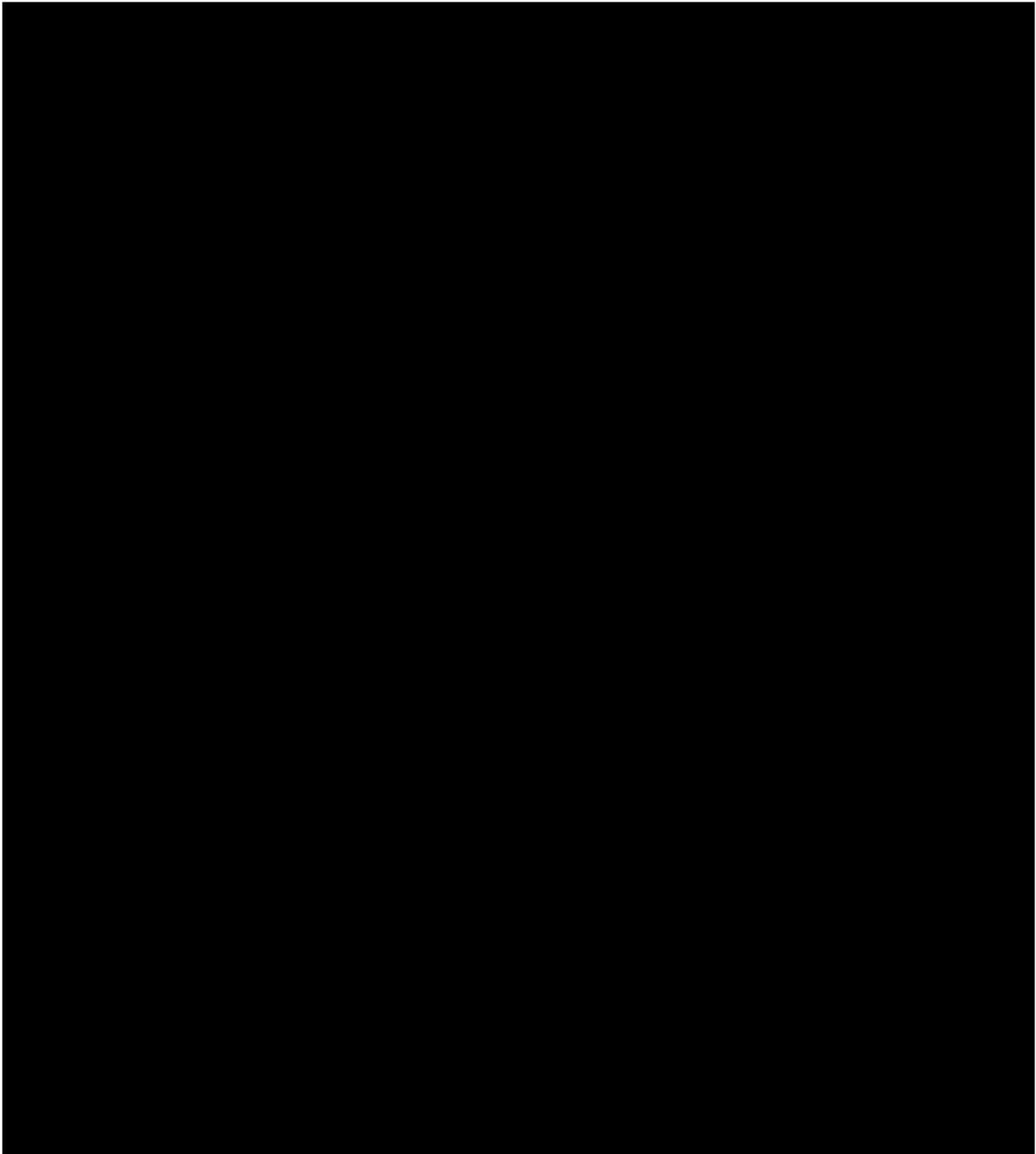

[Signature Page Follows]

IN WITNESS WHEREOF, the parties hereto have executed this Agreement as of the dates set forth below, and this Agreement shall be in full force and effect effective as of the date the Company executes this Agreement as set forth below.

Company:

NSMC-OPCO, LLC

Subscription:

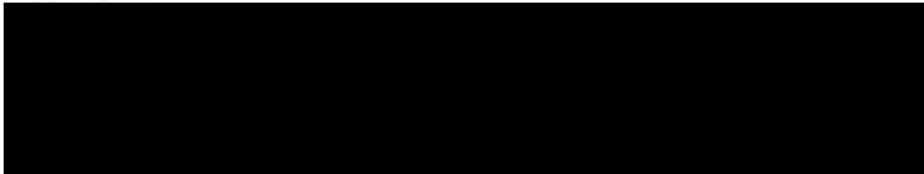

Date: September 5, 2017

Subscriber:

Name: Susan Williams

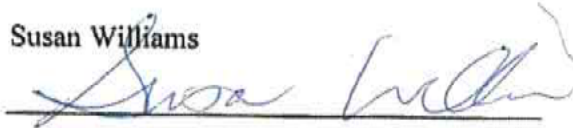
Signature: 

Address: P.O. Box 55130
Little Rock, AR 72215-5130

SSN/Tax ID#: 

ACCEPTANCE

The Company hereby accepts Subscriber's subscription for the Membership Interest upon the terms set forth in this Agreement, as of September ____, 2017.

NSMC-OPCO, LLC

By: 

Joseph C. Courtright, Manager

Section A - Subscription Agreement

IN WITNESS WHEREOF, the parties hereto have executed this Agreement as of the dates set forth below, and this Agreement shall be in full force and effect effective as of the date the Company executes this Agreement as set forth below.

Company:

NSMC-OPCO, LLC

Subscription:

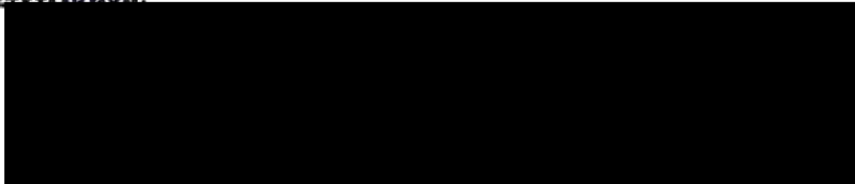

Date: September 1, 2017

Subscriber:

Name: Keith Mooney, M.D.

Signature: Keith Mooney

Address: [Redacted]

SSN/Tax ID#: [Redacted]

ACCEPTANCE

The Company hereby accepts Subscriber's subscription for the Membership Interest upon the terms set forth in this Agreement, as of September 4, 2017.

NSMC-OPCO, LLC

By: Joseph C. Courtright
Joseph C. Courtright, Manager

Section A - Subscription Agreement

IN WITNESS WHEREOF, the parties hereto have executed this Agreement as of the dates set forth below, and this Agreement shall be in full force and effect effective as of the date the Company executes this Agreement as set forth below.

Company:

NSMC-OPCO, LLC

Subscription:



Date: September 1st, 2017

Subscriber:

Name: Joseph C. Courtright

Signature: _____

A handwritten signature in blue ink, appearing to read "JC Courtright", written over a horizontal line.

Address: _____



SSN/Tax ID#: _____



ACCEPTANCE

The Company hereby accepts Subscriber's subscription for the Membership Interest upon the terms set forth in this Agreement, as of September 1st, 2017.

NSMC-OPCO, LLC

By: _____

Joseph C. Courtright, Manager

A handwritten signature in blue ink, appearing to read "JC Courtright", written over a horizontal line.

Section A - Subscription Agreement

IN WITNESS WHEREOF, the parties hereto have executed this Agreement as of the dates set forth below, and this Agreement shall be in full force and effect effective as of the date the Company executes this Agreement as set forth below.

Company:

NSMC-OPCO, LLC

Subscription:



Date: September ____, 2017

Subscriber:

Name: Stephen L. LaFrance, Jr.

Signature: _____

A handwritten signature in blue ink, appearing to read "S. LaFrance, Jr.", written over a horizontal line.

Address: _____

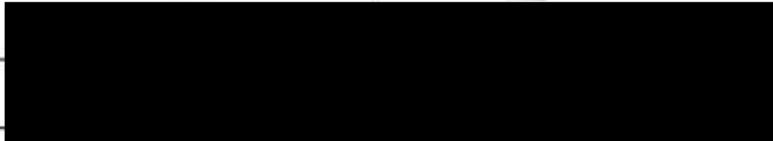

SSN/Tax ID#: _____



ACCEPTANCE

The Company hereby accepts Subscriber's subscription for the Membership Interest upon the terms set forth in this Agreement, as of September ____, 2017.

NSMC-OPCO, LLC

By: _____

Joseph C. Courtright, Manager

A handwritten signature in blue ink, appearing to read "Joseph C. Courtright", written over a horizontal line.

Section A - Subscription Agreement

IN WITNESS WHEREOF, the parties hereto have executed this Agreement as of the dates set forth below, and this Agreement shall be in full force and effect effective as of the date the Company executes this Agreement as set forth below.

Company:

NSMC-OPCO, LLC

Subscription:



Date: September 4, 2017

Subscriber:

Name: Wendy LaFrance
Signature: Wendy LaFrance
Address: P.O. Box 250530
Little Rock, AR 72207
SSN/Tax ID#: [REDACTED]

ACCEPTANCE

The Company hereby accepts Subscriber's subscription for the Membership Interest upon the terms set forth in this Agreement, as of September 4, 2017.

NSMC-OPCO, LLC

By: Joseph C. Courtright
Joseph C. Courtright, Manager

Section A - Subscription Agreement

IN WITNESS WHEREOF, the parties hereto have executed this Agreement as of the dates set forth below, and this Agreement shall be in full force and effect effective as of the date the Company executes this Agreement as set forth below.

Company:

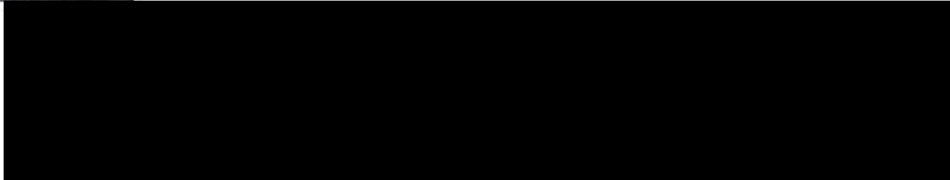

NSMC-OPCO, LLC

Subscription:

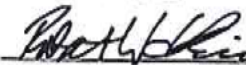

Date: September 4, 2017

Subscriber:

Name: Robert DeBin
Signature: 
Address: PO Box 26836
Little Rock, AR 72221
SSN/Tax ID#: 

ACCEPTANCE

The Company hereby accepts Subscriber's subscription for the Membership Interest upon the terms set forth in this Agreement, as of September 4, 2017.

NSMC-OPCO/LLC

By: 
Joseph C. Courtright, Manager

Section A - Subscription Agreement

IN WITNESS WHEREOF, the parties hereto have executed this Agreement as of the dates set forth below, and this Agreement shall be in full force and effect effective as of the date the Company executes this Agreement as set forth below.

Company:

NSMC-OPCO, LLC

Subscription:

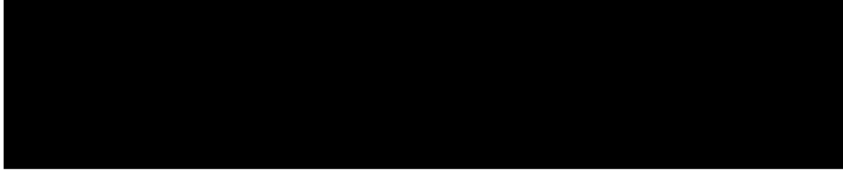

Date: September 4th, 2017

Subscriber:

Name: Donna Terrell

Signature: 

Address: 

SSN/Tax ID#: 

ACCEPTANCE

The Company hereby accepts Subscriber's subscription for the Membership Interest upon the terms set forth in this Agreement, as of September 4th, 2017.

NSMC-OPCO, LLC

By: 
Joseph C. Courtright, Manager

Section A - Subscription Agreement

IN WITNESS WHEREOF, the parties hereto have executed this Agreement as of the dates set forth below, and this Agreement shall be in full force and effect effective as of the date the Company executes this Agreement as set forth below.

Company:

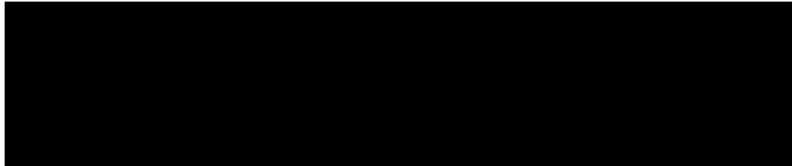

NSMC-OPCO, LLC

Subscription:



Date: September 4, 2017

Subscriber:

Name: Scott M. Schlesinger, M.D.
Signature: 
Address: 
SSN/Tax ID#: 

ACCEPTANCE

The Company hereby accepts Subscriber's subscription for the Membership Interest upon the terms set forth in this Agreement, as of September , 2017.

NSMC-OPCO, LLC

By: 
Joseph C. Courtright, Manager

Section A - Subscription Agreement

IN WITNESS WHEREOF, the parties hereto have executed this Agreement as of the dates set forth below, and this Agreement shall be in full force and effect effective as of the date the Company executes this Agreement as set forth below.

Company:

NSMC-OPCO, LLC

Subscription:

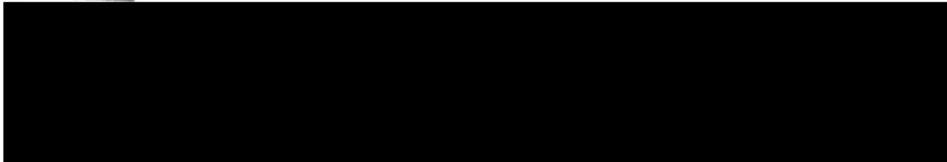

Date: September 4, 2017

Subscriber:

Name: Kelli S. , M.D.

Signature: _____

Address: _____

SSN/Tax ID#: _____

ACCEPTANCE

The Company hereby accepts Subscriber's subscription for the Membership Interest upon the terms set forth in this Agreement, as of September 4th, 2017.

NSMC-OPCO, LLC

By: _____

Joseph C. Courtright, Manager

Section A - Subscription Agreement

IN WITNESS WHEREOF, the parties hereto have executed this Agreement as of the dates set forth below, and this Agreement shall be in full force and effect effective as of the date the Company executes this Agreement as set forth below.

Company:

NSMC-OPCO, LLC

Subscription:

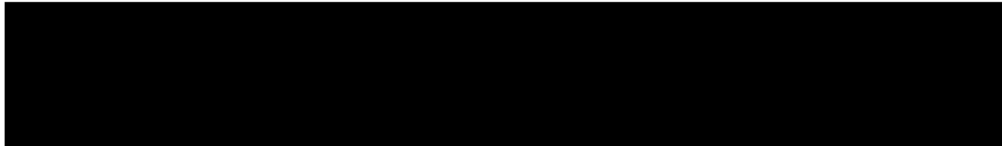

Date: September 3, 2017

Subscriber:

Name: Deane Peck

Signature: *Deane Peck*

Address: 

SSN/Tax ID#: 

ACCEPTANCE

The Company hereby accepts Subscriber's subscription for the Membership Interest upon the terms set forth in this Agreement, as of September , 2017.

NSMC-OPCO, LLC

By: *Joseph C. Courtright*

Joseph C. Courtright, Manager

Section A - Subscription Agreement

IN WITNESS WHEREOF, the parties hereto have executed this Agreement as of the dates set forth below, and this Agreement shall be in full force and effect effective as of the date the Company executes this Agreement as set forth below.

Company:

NSMC-OPCO, LLC

Subscription:

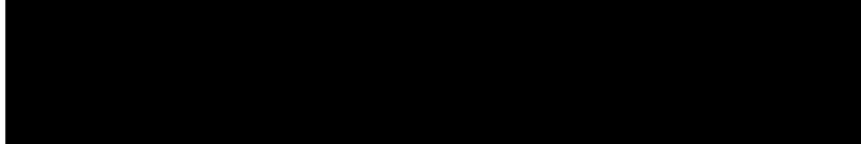

Date: September 3, 2017

Subscriber:

Name: Cliff Peck

Signature:

Handwritten signature of Cliff Peck in black ink.

Address:

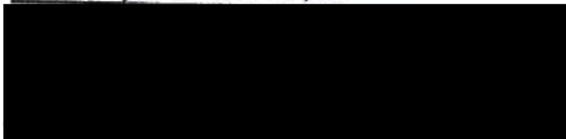

SSN/Tax ID#:

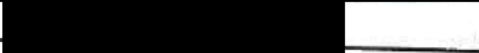

ACCEPTANCE

The Company hereby accepts Subscriber's subscription for the Membership Interest upon the terms set forth in this Agreement, as of September 4, 2017.

NSMC-OPCO, LLC

By:

Handwritten signature of Joseph C. Courtright in blue ink.

Joseph C. Courtright, Manager

Section A - Subscription Agreement

IN WITNESS WHEREOF, the parties hereto have executed this Agreement as of the dates set forth below, and this Agreement shall be in full force and effect effective as of the date the Company executes this Agreement as set forth below.

Company:

NSMC-OPCO, LLC

Subscription:

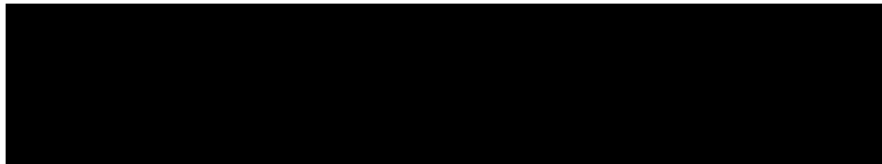

Date: September 1, 2017

Subscriber:

Name: Donna Mooney, Ph.D.

Signature: Donna Mooney

Address: [Redacted]

SSN/Tax ID#: [Redacted]

ACCEPTANCE

The Company hereby accepts Subscriber's subscription for the Membership Interest upon the terms set forth in this Agreement, as of September 4, 2017.

NSMC-OPCO, LLC

By: Joseph C. Courtright
Joseph C. Courtright, Manager

Section A - Subscription Agreement

IN WITNESS WHEREOF, the parties hereto have executed this Agreement as of the dates set forth below, and this Agreement shall be in full force and effect effective as of the date the Company executes this Agreement as set forth below.

Company:

NSMC-OPCO, LLC

Subscription:

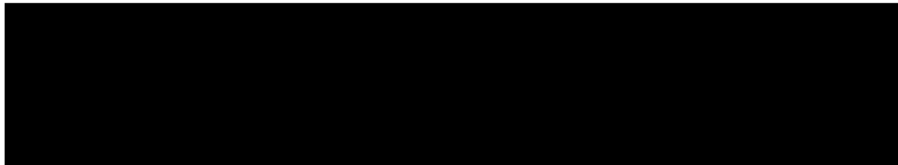

Date: September 5, 2017

Subscriber:

Name: Alonzo Williams, M.D.

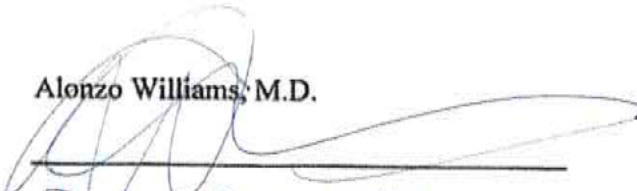
Signature: 

Address: P.O. Box 55130
Little Rock, AR 72215-5130

SSN/Tax ID#: 

ACCEPTANCE

The Company hereby accepts Subscriber's subscription for the Membership Interest upon the terms set forth in this Agreement, as of September ____, 2017.

NSMC-OPCO, LLC

By: 

Joseph C. Courtright, Manager

Exhibit A

Risk Factors

The Company has no operating history, and may never be profitable.

Because the Company has only conducted limited operations to date, and has an unproven business plan, it may be difficult for potential investors to evaluate the Company's business. There can be no assurance that the Company will be profitable or that the securities which may be sold in this offering will ultimately have any value.

The Company's proposed business is dependent on laws pertaining to the marijuana industry.

Continued development of the marijuana industry is dependent upon continued legislative authorization of marijuana at the state level. Any number of factors could slow or halt progress in this area. Further, progress for the industry, while encouraging, is not assured. While there may be ample public support for legislative action, numerous factors impact the legislative process. Any one of these factors could slow or halt use of marijuana, which would negatively impact the Company's proposed business.

Currently, approximately 28 states and the District of Columbia allow its citizens to use medical marijuana. Voters in the states of Colorado, Washington, Alaska, Oregon and the District of Columbia have approved ballot measures to legalize cannabis for adult use. These state laws are in conflict with the federal Controlled Substances Act (the "CSA"), which makes marijuana use and possession illegal on a national level. The former Obama administration effectively stated that it is generally not an efficient use of resources to direct federal law enforcement agencies to prosecute those lawfully abiding by state designated laws allowing the use and distribution of marijuana for legitimate medical purposes. However, this policy apparently is under review by the U.S. Department of Justice, so there is no guarantee that the current Trump administration or future administrations will not change this stated policy regarding the low priority enforcement of federal laws. Additionally, the new Trump administration or future administrations could change this policy and decide to enforce the federal laws strongly. Any such change in the federal government's enforcement of current federal laws could cause significant financial damage to the Company and its proposed business.

Further, since the Company's contemplated business is to cultivate, plant, grow, harvest, sell and distribute cannabis, the Company therefore would be deemed to be engaging in a business that remains illegal under federal law, and this exposes the Company and its owners and operators to potential criminal liability, with the additional risk that the Company's assets and properties could be subject to forfeiture proceedings.

The marijuana industry faces strong opposition.

It is believed by many that large well-funded businesses may have a strong economic opposition to the marijuana industry. For example, the pharmaceutical industry likely does not want to cede control of any product that could generate significant revenue, and medical marijuana could adversely impact the existing market for the current "marijuana pill" sold by mainstream pharmaceutical companies. Further, the medical marijuana industry could face a material threat from the pharmaceutical industry, should marijuana displace other drugs or encroach upon the pharmaceutical industry's products. The pharmaceutical industry is well funded with a strong and experienced lobby that eclipses the funding of the medical marijuana movement. Any inroads the pharmaceutical industry could make in halting or impeding the marijuana industry could have a detrimental impact on the Company and its proposed business.

Marijuana remains illegal under Federal law.

Marijuana is a schedule-I controlled substance and is illegal under federal law. Even in those states in which the use of marijuana has been legalized, its use remains a violation of federal law. Since federal law criminalizing the use of marijuana preempts state laws that legalize its use, strict enforcement of federal law regarding marijuana would likely have a material adverse effect on the Company and likely result in the Company's inability to proceed with and implement the Company's business plan.

Laws and regulations affecting the medical marijuana industry are constantly changing, which could detrimentally affect the Company's proposed operations.

Local, state and federal marijuana laws and regulations are broad in scope and subject to evolving interpretations, which could require the Company to incur substantial costs associated with compliance or alter its business plan. In addition, violations of these laws, or allegations of such violations, could disrupt the Company's business and result in a material adverse effect on the Company and its operations. Further, it is possible that regulations may be enacted in the future that will be directly applicable to the Company's proposed business. The Company cannot predict the nature of any future laws, regulations, interpretations or applications, nor can the Company determine what effect additional governmental regulation may have on the Company's proposed business.

The Company may have difficulty accessing the service of banks, which may make it difficult for the Company to operate.

Since the use of marijuana is illegal under federal law, many banks do not accept for deposit funds from businesses involved with the marijuana industry. Consequently, businesses involved in the marijuana industry often have difficulty finding a bank willing to accept their business. The inability to open or maintain bank accounts may make it more difficult for the Company to operate its contemplated business.

FDA regulation of marijuana and the possible registration of facilities where medical marijuana is grown could negatively affect the cannabis industry which would directly affect the Company's financial condition.

Should the federal government legalize marijuana for medical use, it is possible that the U.S. Food and Drug Administration (FDA) would seek to regulate it under the Food, Drug and Cosmetics Act of 1938. Additionally, the FDA may issue rules and regulations including cGMPs (current good manufacturing practices) related to the growth, cultivation, harvesting and processing of medical marijuana. Clinical trials may be needed to verify efficacy and safety. It is also possible that the FDA would require that facilities where medical marijuana is grown be registered with the FDA and comply with certain federally prescribed regulations. In the event that any of these regulations are imposed, the Company does not know what the impact would be on the medical marijuana industry generally, or on the Company, in particular, or what costs, requirements and possible prohibitions may be enforced that would negatively affect the Company and its business.

Because the contemplated business activities of the Company are illegal under Federal law, the Company will be engaging in illegal activities under Federal law. As a result, the Company may be subject to actions by law enforcement authorities which would materially and adversely affect the Company and its business.

The Company's contemplated business is to cultivate, plant, grow, harvest, sell and distribute cannabis. As a result, law enforcement authorities or other third parties may seek to bring an action or actions against the Company, including, but not limited to, a claim of engaging in, or aiding and abetting, criminal activities. Such an action or actions would have a material adverse effect on the Company and its proposed business and operations.

If the Company incurs substantial liability from litigation, complaints, or enforcement actions, the Company's financial condition could suffer.

The Company's participation in the medical cannabis industry may lead to litigation, formal or informal complaints, enforcement actions, and inquiries by various federal, state, or local governmental authorities, or other third parties, against the Company. Such litigation, complaints, and enforcement actions could consume considerable amounts of financial and other Company resources, which could have a negative impact on the Company and its financial position and business prospects.

Section 280E of the Internal Revenue Code disallows deductions for income tax purposes for taxpayers in the marijuana business.

Section 280E of the Internal Revenue Code disallows deductions for income tax determination purposes with respect to any amount paid or incurred in carrying on any trade or business if such trade or business (or the activities which comprise such trade or business) consists of trafficking in certain controlled substances (including marijuana). Accordingly, marijuana businesses may not take any deductions otherwise allowable in determining the taxable income of such business (and applicable income tax), except deductions for costs of goods sold. Therefore, to the extent the Company's business or activities consists of trafficking in marijuana, the Company's tax

Section A - Subscription Agreement

deductions may be severely limited, thereby resulting in the Company having to report higher taxable income (and the Company or its owners owing higher effective income taxes on the Company's income) than would otherwise be the case if the Company was in some other business.

INITIAL OPERATING AGREEMENT
OF
NSMC-OPCO, LLC

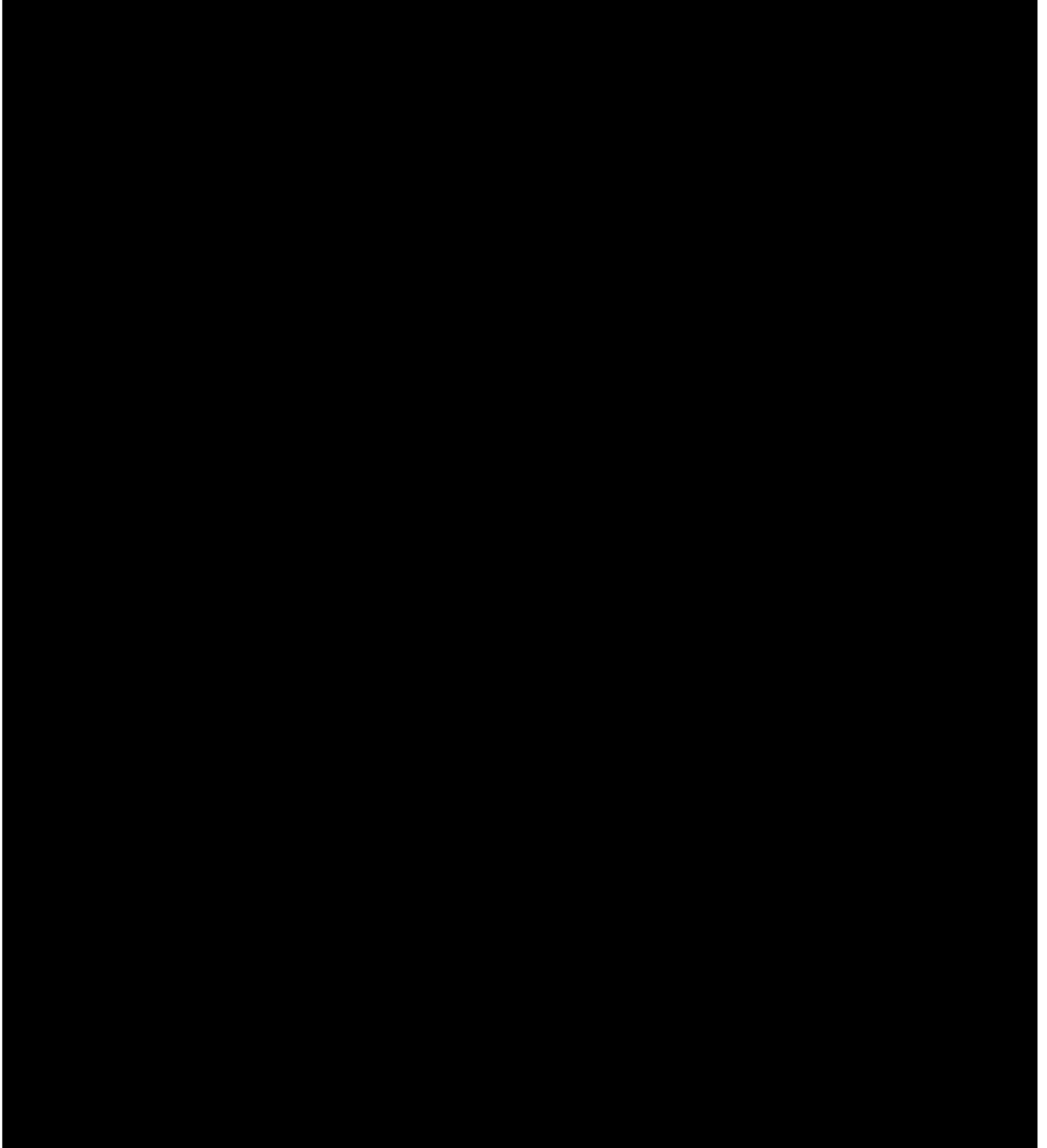

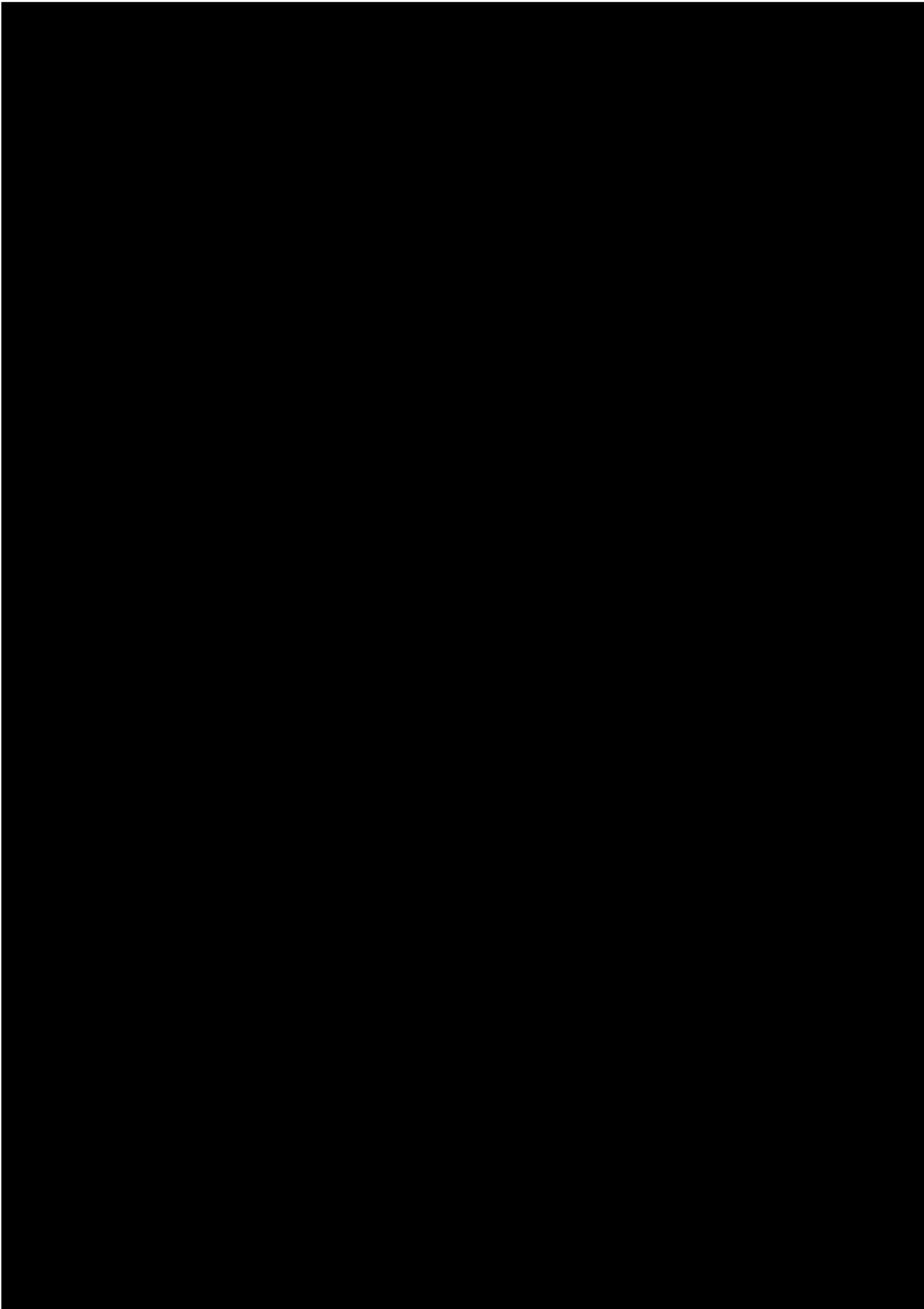

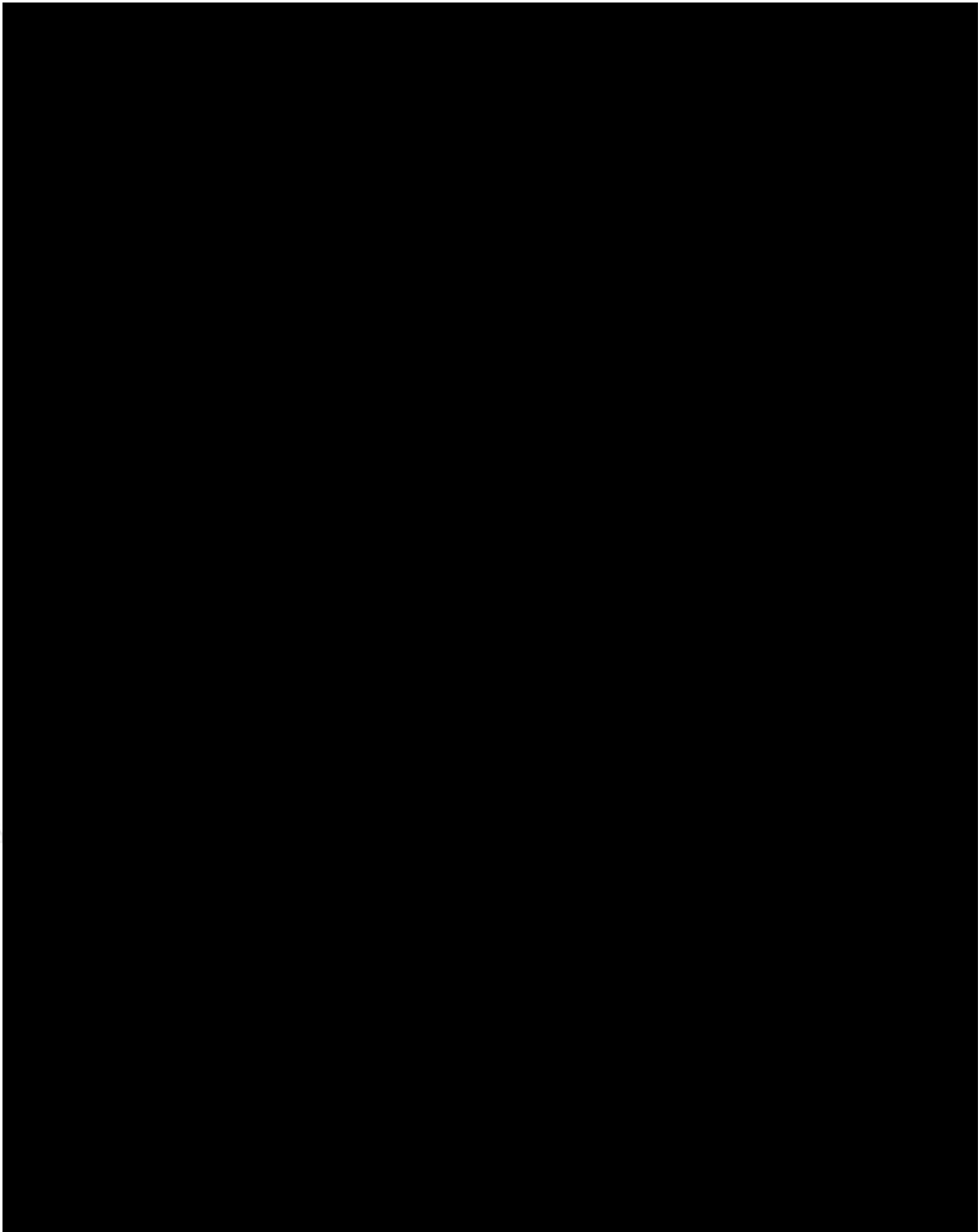

Joseph C. Courtright - Manager, Chairman, President and CEO
Robert DeBin - Manager and Vice President IT and Business
Development; and
Donna Terrell - Vice President - Community Outreach.

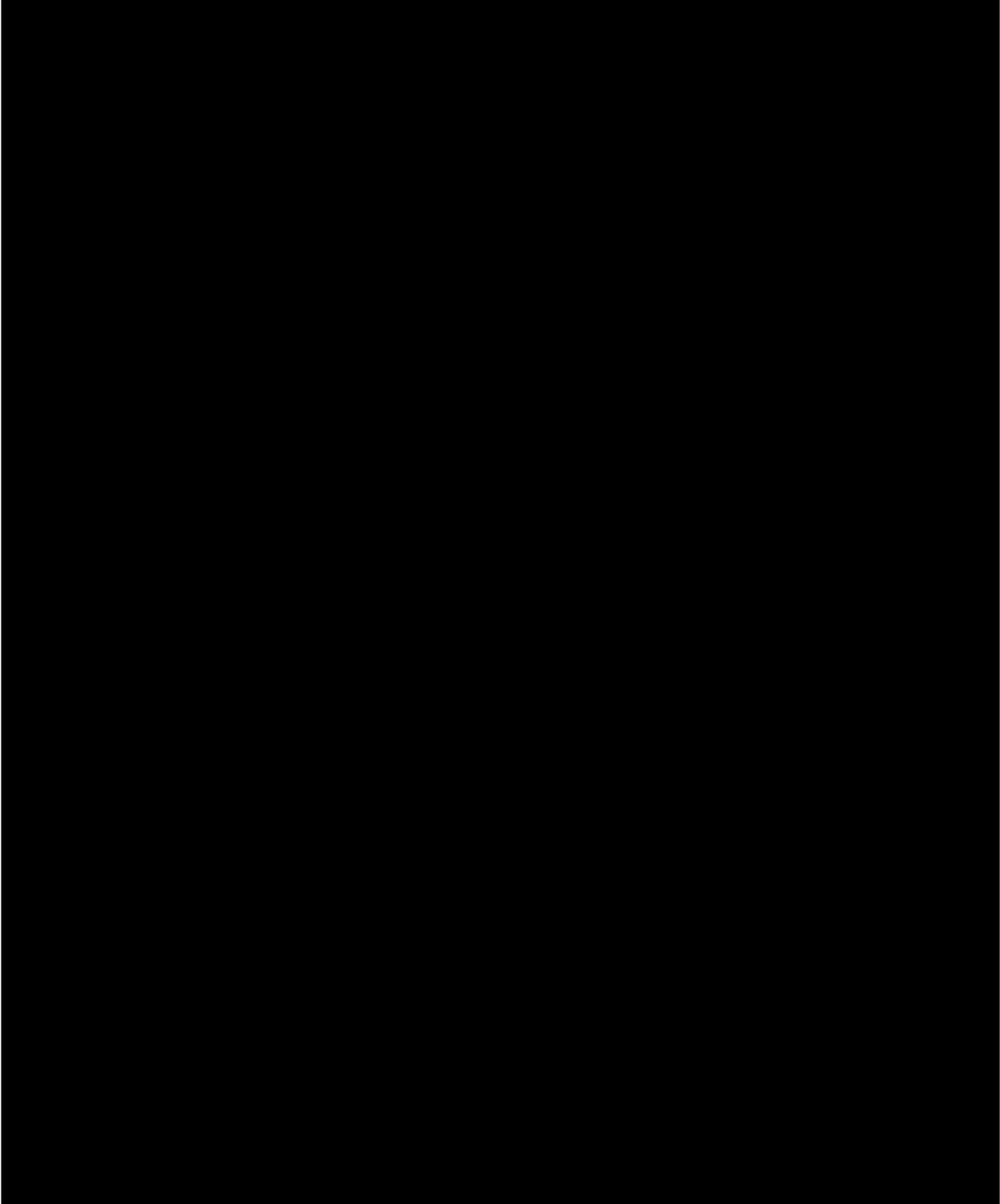

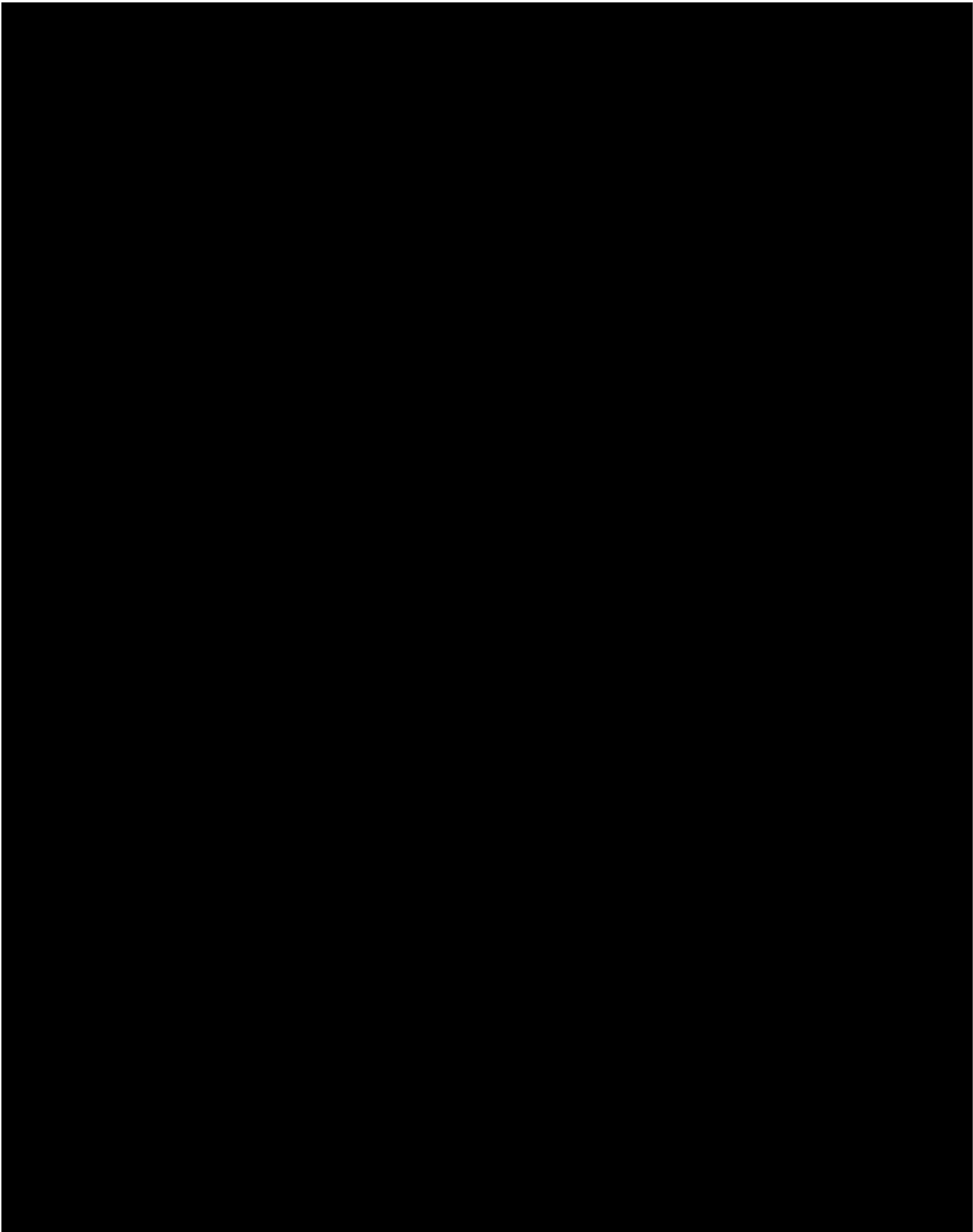

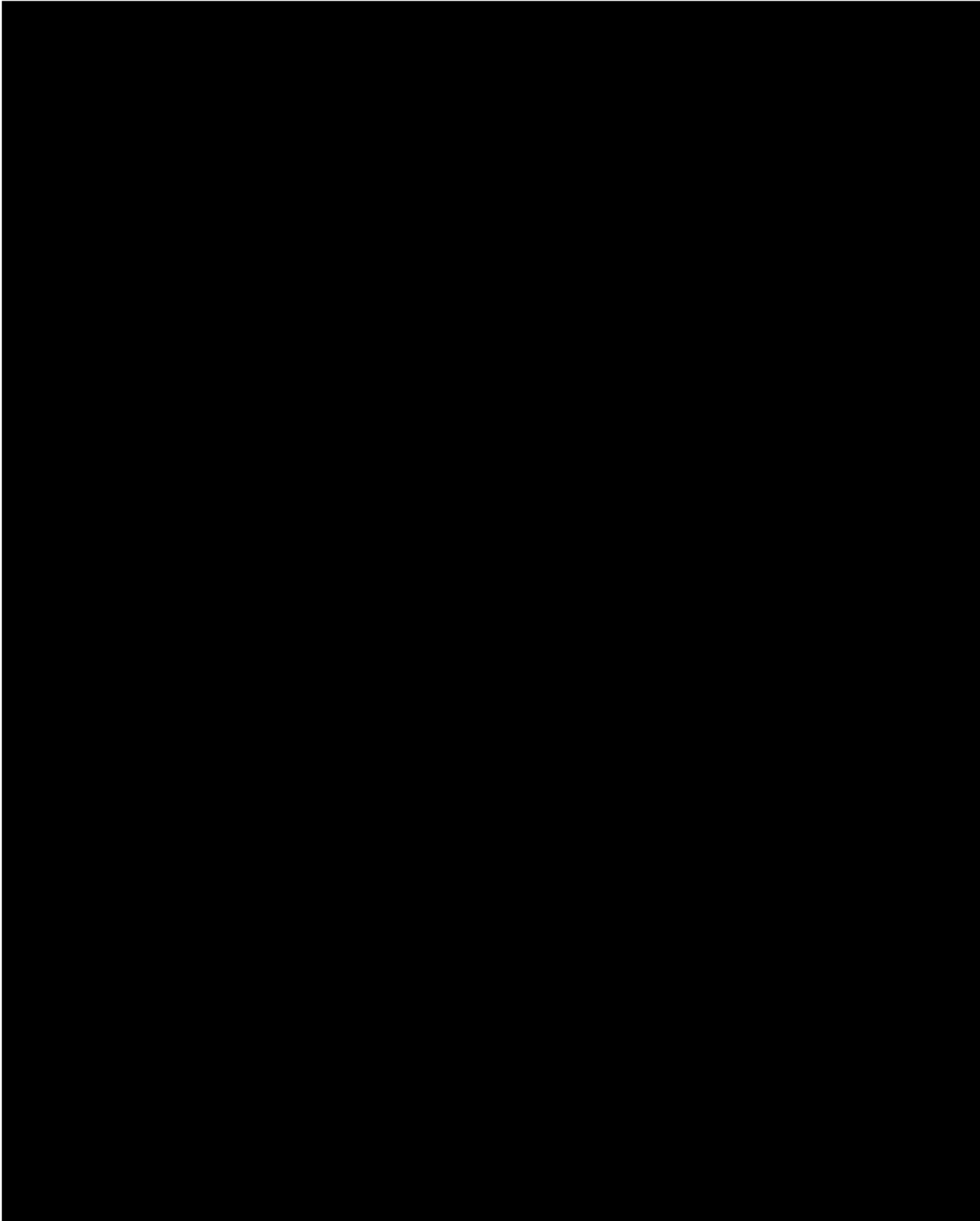

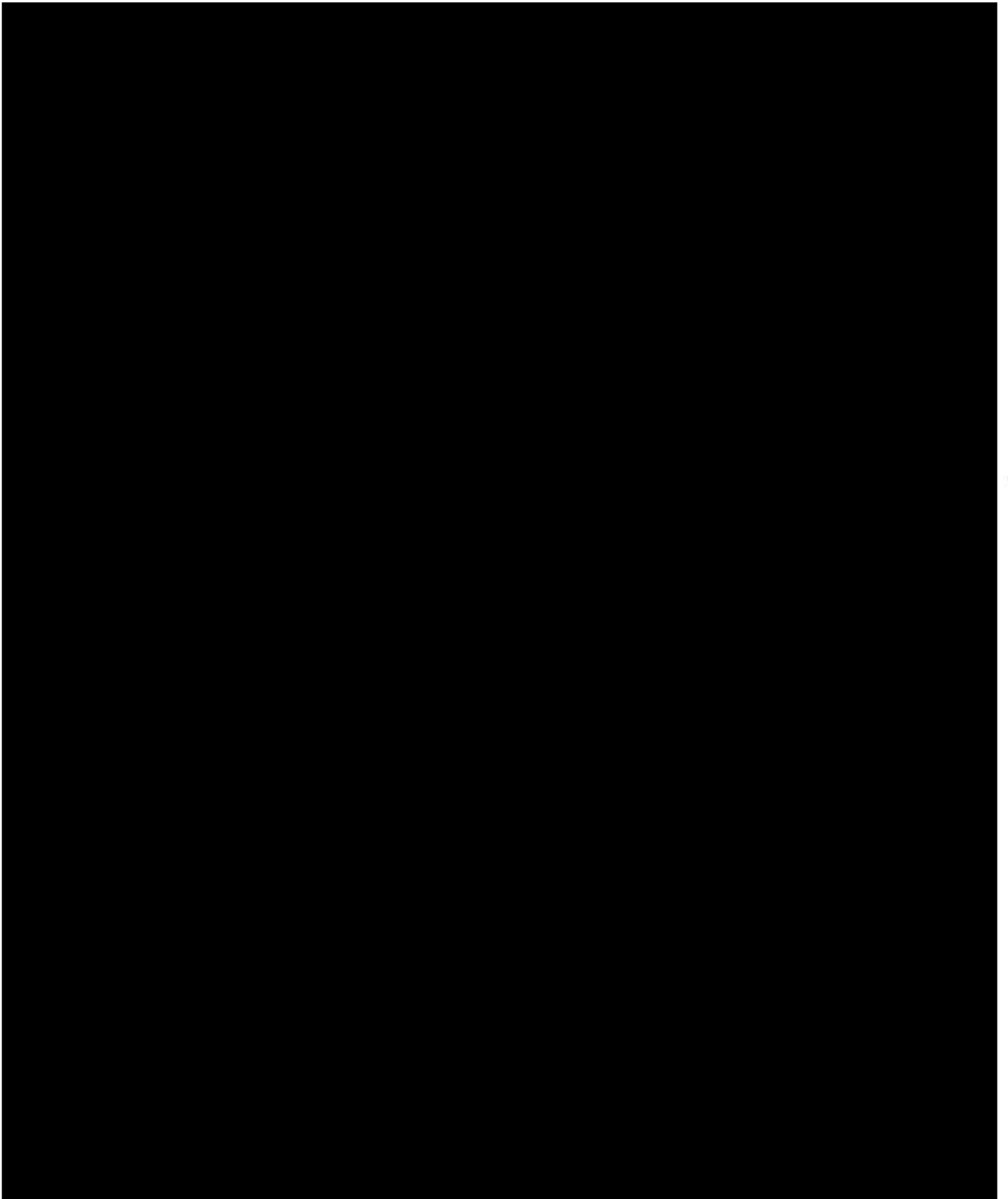

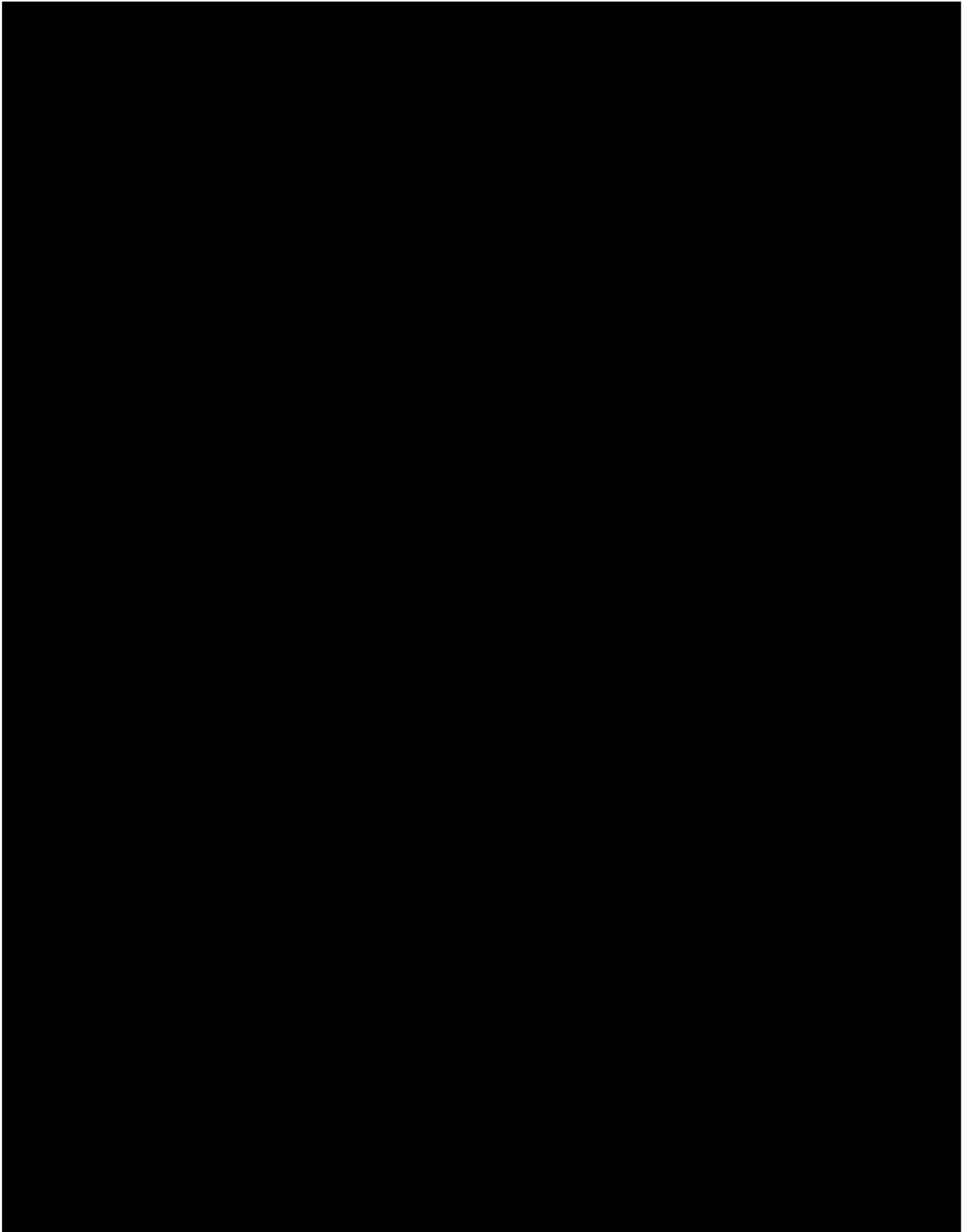

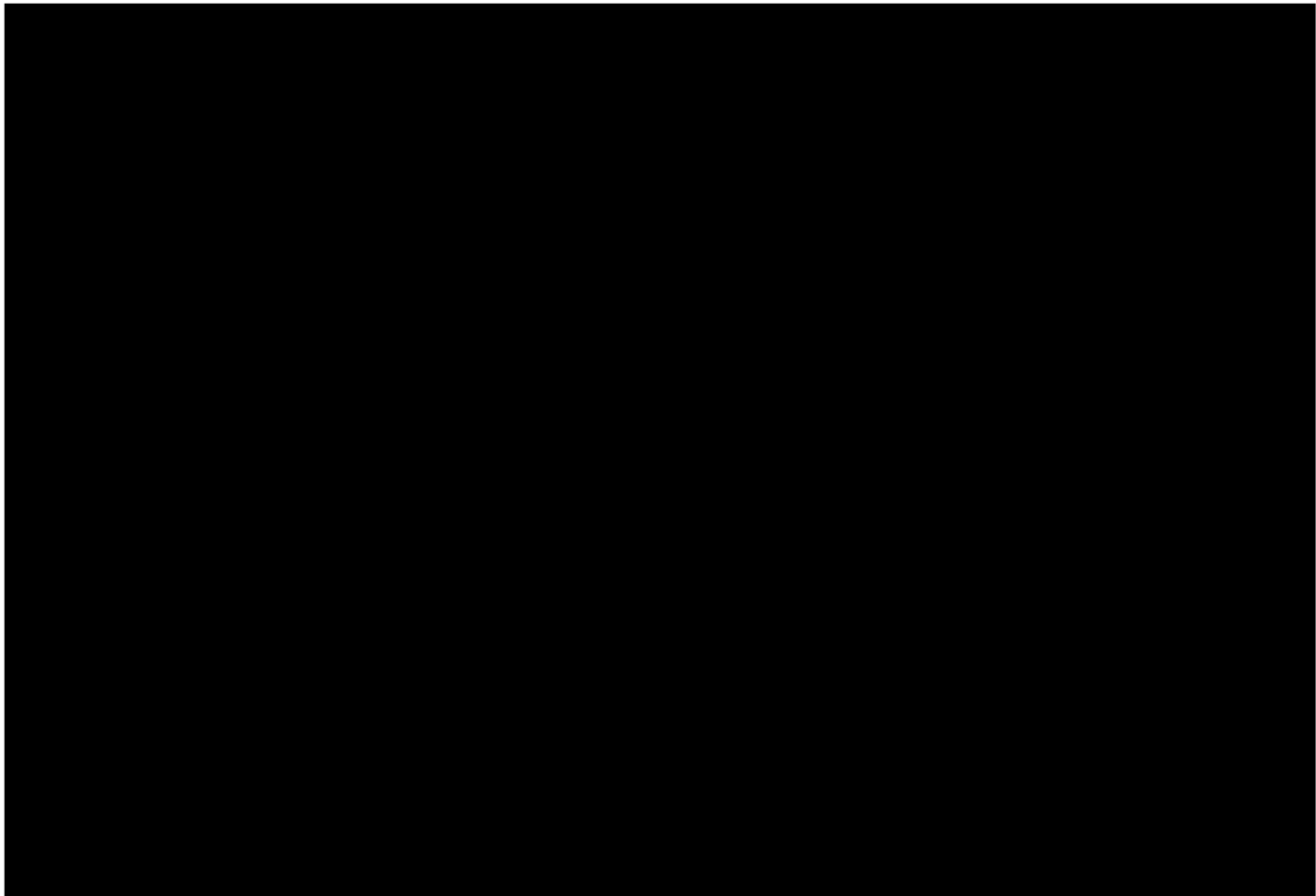

[signature page follows]

IN WITNESS WHEREOF, the undersigned have executed this Agreement to be effective as of the Effective Date.

COMPANY:

NSMC-OPCO, LLC

By:



Joseph C. Courtright, Manager, Chairman,
President and CEO

SOLE MEMBER:



Joseph C. Courtright

MANAGERS:



Joseph C. Courtright



Robert DeBin

Donna Terrell

IN WITNESS WHEREOF, the undersigned have executed this Agreement to be effective as of the Effective Date.

COMPANY:

NSMC-OPCO, LLC

By: 
Joseph C. Courtright, Manager, Chairman,
President and CEO

SOLE MEMBER:

Joseph C. Courtright

MANAGERS:

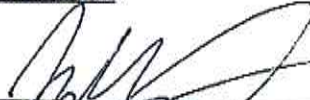
Joseph C. Courtright

Robert DeBin



Donna Terrell

EXHIBIT A

Name of Member	Initial Capital Contribution	Units of Membership Interest	Membership Interest
Joseph C. Courtright			100%

NSMC-OPCO, LLC
CERTIFICATE OF MEMBERSHIP INTEREST REGISTER

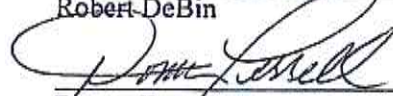
<u>NO.</u>	<u>EFFECTIVE DATE ISSUED</u>	<u>MEMBER'S NAME</u>	<u># OF UNITS</u>	<u>DATE CANCELED</u>
1	August 3, 2017	Joseph C. Courtright	100	

CERTIFICATE OF OWNERSHIP AND MEMBERSHIP INTEREST
NSMC-OPCO, LLC

This document certifies that Joseph C. Courtright (the "Member") is the owner of one hundred (100) units of membership interest in **NSMC-OPCO, LLC** (the "Company"), an Arkansas limited liability company. The rights of the holder hereof are as provided in the Operating Agreement of the Company dated effective as of August 3, 2017, as may be amended from time to time in accordance with the terms thereof.

IN WITNESS WHEREOF, the Company has caused this Certificate to be issued to the aforesaid Member effective as of August 3, 2017.

NSMC-OPCO, LLC

By:



Joseph C. Courtright, Manager, Chairman,
President and CEO

RESTRICTIONS ON TRANSFER

THE SECURITIES REPRESENTED BY THIS CERTIFICATE HAVE NOT BEEN REGISTERED PURSUANT TO THE SECURITIES ACT OF 1933, AS AMENDED, OR ANY OTHER APPLICABLE FEDERAL OR STATE SECURITIES LAWS, AND, ACCORDINGLY, MAY NOT BE OFFERED, SOLD, TRANSFERRED, PLEDGED OR HYPOTHECATED IN THE ABSENCE OF REGISTRATION OR THE AVAILABILITY OF AN EXEMPTION FROM REGISTRATION UNDER THE SECURITIES ACT OF 1933, AS AMENDED, AND ANY OTHER APPLICABLE SECURITIES LAWS. IN ADDITION, ANY PROPOSED SALE, TRANSFER OR OTHER DISPOSITION OF THE UNITS REPRESENTED BY THIS CERTIFICATE MUST COMPLY WITH ALL APPLICABLE TERMS, PROVISIONS AND CONDITIONS OF THE COMPANY'S OPERATING AGREEMENT, A COPY OF WHICH IS ON FILE AT THE COMPANY'S PRINCIPAL OFFICE. ANY TRANSFER CONTRARY TO THE ABOVE INSTRUCTIONS SHALL BE VOID.

APPLICATION FOR MEDICAL MARIJUANA CULTIVATION FACILITY

SECTION B. Applicant, Owner, Officer, or Board Member Disclosure Statement

Identify your affiliation with the proposed cultivation facility (Applicant, Owner, Officer, Board Member?) Include your percentage of equity ownership in the facility, if any.

Affiliation: Owner

Percentage of Equity Ownership: 8.45%

Legal Name

*In addition to the information below, you are required to provide supporting documents to prove your legal name. See Section B, Appendix 1 for acceptable forms of proof.

Last Name Williams, Sr.

First Name Alonzo

Middle Name Dean

Maiden Name (if applicable) _____

Alias(es) or former names _____

SSN [REDACTED]

Date of Birth

*In addition to providing your date of birth, you are required to provide supporting documents to prove your date of birth. See Section B, Appendix 2 for acceptable forms of proof.

Date of Birth [REDACTED]

Contact Information

Mailing Address P.O. Box 55130

Little Rock, AR 72215

Phone Number (primary contact number) [REDACTED]

Email Address awilliams@adc.lr.com

Residency

Are you an Arkansas resident? Yes

If you are not an Arkansas resident, please identify your primary place of residence.

Have you been an Arkansas resident for the past seven (7) years? Yes

If you answered "yes" to the question above, in addition to providing the information requested below, you are required to provide supporting documents to prove your residency for the past seven (7) years. See Section B, Appendix 3 for acceptable forms of proof.

Provide the address of your primary residence(s) for the past seven (7) years. Identify the dates (month and year) you resided at each listed location:

 10/2006 - Present

Tax Liability

Do you have any outstanding tax delinquencies owed to the State of Arkansas: No

If you answered "yes" to the previous question, please explain the nature of any delinquencies:

Other Financial Liabilities

Are you a party to any legal proceedings where damages, fines, or civil penalties may reasonably be expected to exceed \$500,000 above any insurance coverage available to cover the claim?

No

If the answer to the above question is “yes”, attach a statement describing the litigation, including the title and docket number of the litigation, the name and location of the court in which it is pending, the identity of all parties to the litigation, the general nature of the claims being made and the impact an unfavorable opinion may have on your ability to finance and operate the proposed cultivation facility. Any documents submitted in response to this requirement must be labeled with “Section B, Other Financial Liabilities”.

Regulatory History

Have you, or has any entity over which you exercised management or control, ever had any fines or other penalties over \$10,000 assessed by any regulatory agency? **Yes**

If the answer above is “yes”, attach a statement providing the details of such fines or penalties. Any documents submitted in response to this requirement must be labeled with “Section B, Regulatory History”.

Professional Licensure

Do you presently hold any type of professional license? **Yes**

If yes, identify the type of license and license number AR Medical License: [REDACTED]; DEA: [REDACTED]

Is the license in good standing? **Yes**

Certification

I, Alonzo D. Williams, Sr., certify that the information provided in this form and its attachments is complete and accurate. I understand that any misstatement or concealment of fact may be grounds for refusal of application or revocation of license if later disclosed.

Signed this 2nd day of August, 2017.



Signature of Applicant, Owner, Officer, or Board Member

Subscribed and sworn to before me this 2nd day of August, 2017.

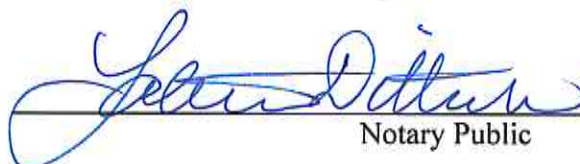

Notary Public

My Commission Expires: 12/19/2026



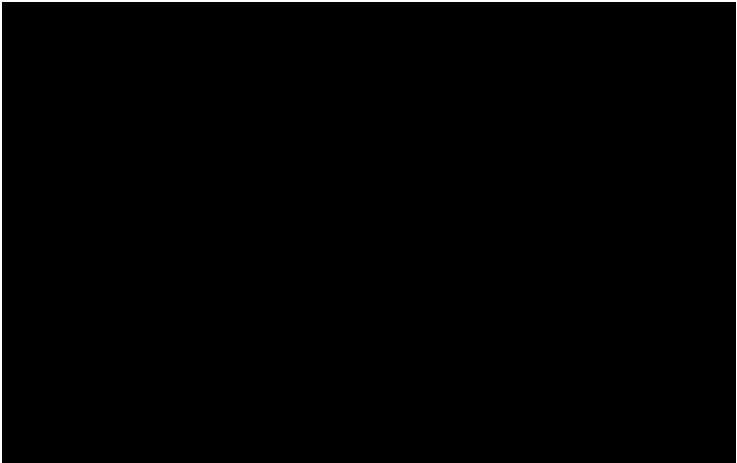
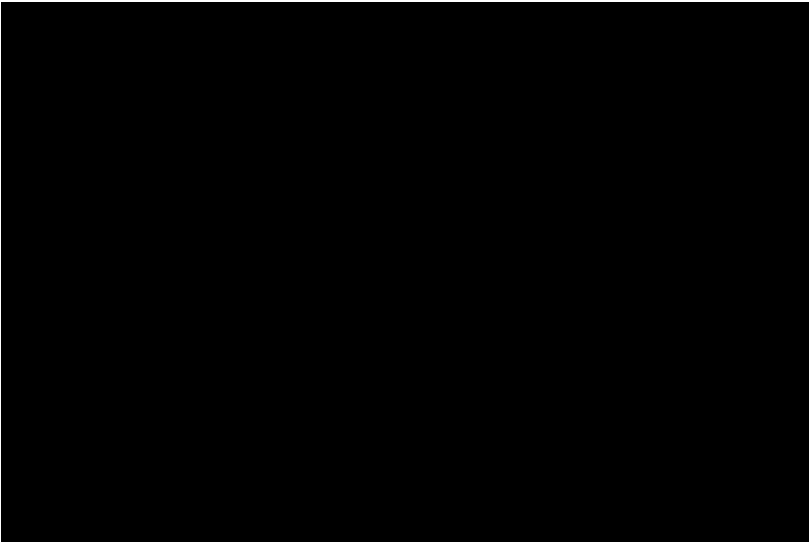

Parcel History Report

Created: 8/2/2017 9:37:10 AM

Basic Information	
Parcel Number:	53L0260145500
County Name:	Pulaski County
Owners Name:	WILLIAMS ALONZO D SR/SUSAN D
Billing Name:	WILLIAMS ALONZO D SR/SUSAN D
Billing Address:	PO BOX 55130
City, State, Zip:	LITTLE ROCK AR 72215

Assessment History

Year	Assessed Land	Assessed Building	Total Assessed	Taxable Value
2017	55,180	126,300	181,480	181,480
2013	34,000	139,220	173,220	173,220
2012	34,000	139,220	173,220	173,220
2012	34,000	198,440	232,440	196,284
2012	34,000	202,150	236,150	196,284
2012	34,000	206,360	240,360	196,284
2010	34,500	152,434	186,934	186,934
2010	34,500	152,434	186,934	186,934
2009	34,500	152,434	186,934	186,934
2008	34,500	152,434	186,934	186,934
2007	34,500	152,434	186,934	186,934
2006	34,500	152,434	186,934	186,934
2005	29,909	157,025	186,934	186,934
2004	30,000	156,934	186,934	186,934
2002	26,790	0	26,790	26,790

Ownership History

Date	Price	Grantor	Grantee	Book	Page	Deed Type
10/4/2006	0	ADC ANESTHESIA SERVICES PLC	WILLIAMS ALONZO D/SUSAN D	2006	083967	WADS ()
6/22/2002	0	PLAT G 417		2002	150897	UNKNOW ()
5/5/2000	0	ADAMETZ J R REV TRUST TO ADC A		00	030706	UNKNOW ()
4/1/1997	2	ADAMETZ TO SAME		97	23987	DEED (Deed)
3/1/1995	804,000			95	12048	DEED (Deed)
3/1/1994	159,000			94	22167	DEED (Deed)
5/5/1900	856,000	ADAMETZ TO ADC ANESTHESIA SERV		00	030707	DEED (Deed)

Individual Voting History Report

Williams, Alonzo Dean Sr

[REDACTED]
[REDACTED]

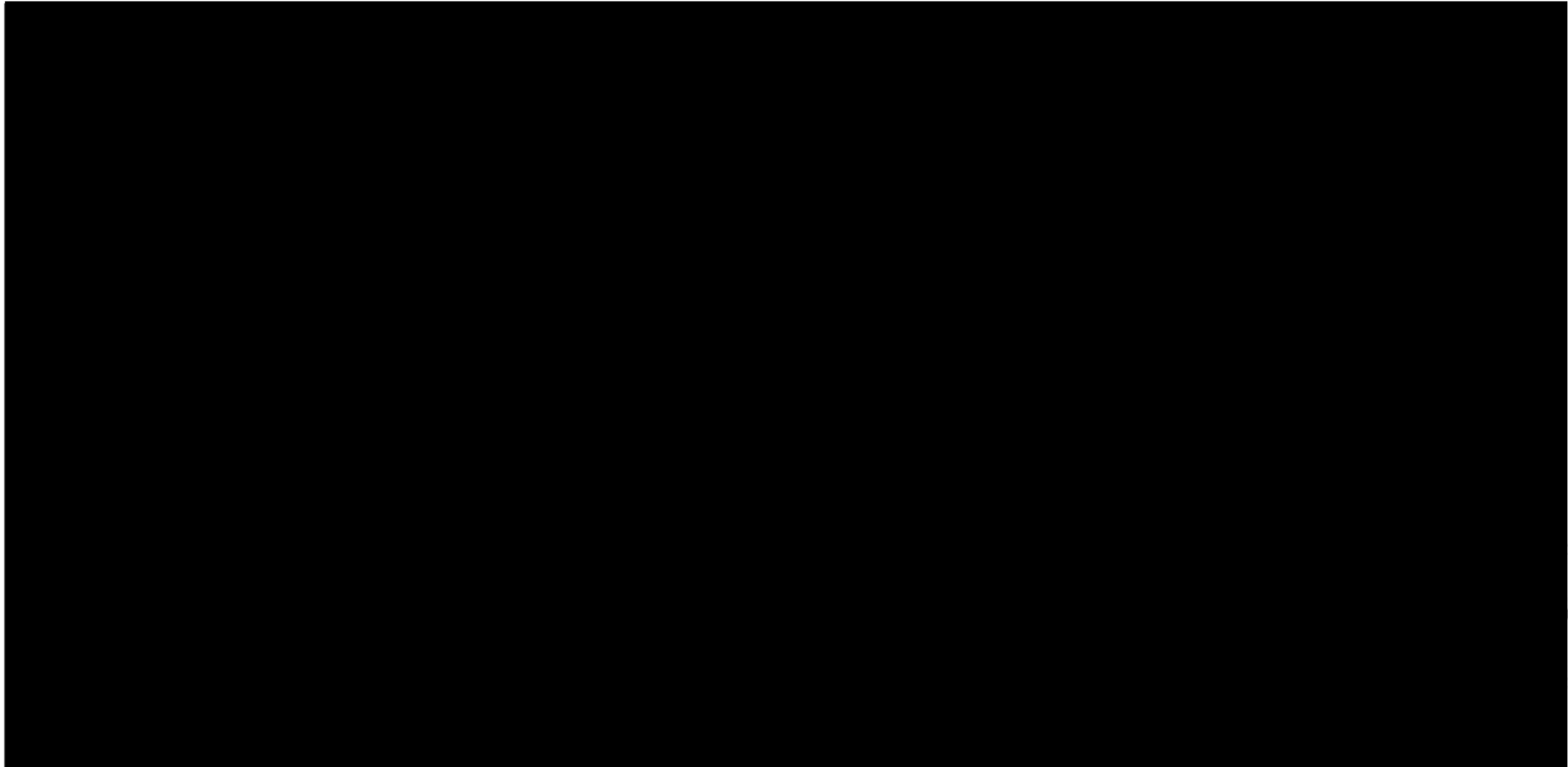

Debit Card
Number: 1234 5678 9010 1112
Expires: 12/31/2023



Section B
Regulatory History



Section B - Professional Licensure

10021682 2/0020149

1:5
78/656
WILLIAMS, ALONZO
PO BOX 55130
8908 KANIS ROAD
LITTLE ROCK, AR 72215-5130



DEA REGISTRATION NUMBER	THIS REGISTRATION EXPIRES	FEE PAID	
[REDACTED]	05-31-2020	\$731	
SCHEDULES	BUSINESS ACTIVITY	ISSUE DATE	
2,2N, 3,3N,4,5,	PRACTITIONER	04-11-2017	
WILLIAMS, ALONZO ARKANSAS DIAGNOSTIC CENTER PO BOX 55130 8908 KANIS ROAD LITTLE ROCK, AR 72215-5130			

CONTROLLED SUBSTANCE REGISTRATION CERTIFICATE
 UNITED STATES DEPARTMENT OF JUSTICE
 DRUG ENFORCEMENT ADMINISTRATION
 WASHINGTON D.C. 20537

Sections 304 and 1008 (21 USC 824 and 958) of the Controlled Substances Act of 1970, as amended, provide that the Attorney General may revoke or suspend a registration to manufacture, distribute, dispense, import or export a controlled substance.

THIS CERTIFICATE IS NOT TRANSFERABLE ON CHANGE OF OWNERSHIP, CONTROL, LOCATION, OR BUSINESS ACTIVITY, AND IT IS NOT VALID AFTER THE EXPIRATION DATE.

CONTROLLED SUBSTANCE REGISTRATION CERTIFICATE
 UNITED STATES DEPARTMENT OF JUSTICE
 DRUG ENFORCEMENT ADMINISTRATION
 WASHINGTON D.C. 20537

DEA REGISTRATION NUMBER	THIS REGISTRATION EXPIRES	FEE PAID	
[REDACTED]	05-31-2020	\$731	
SCHEDULES	BUSINESS ACTIVITY	ISSUE DATE	
2,2N, 3,3N,4,5,	PRACTITIONER	04-11-2017	
WILLIAMS, ALONZO ARKANSAS DIAGNOSTIC CENTER PO BOX 55130 8908 KANIS ROAD LITTLE ROCK, AR 72215-5130			

Sections 304 and 1008 (21 USC 824 and 958) of the Controlled Substances Act of 1970, as amended, provide that the Attorney General may revoke or suspend a registration to manufacture, distribute, dispense, import or export a controlled substance.

THIS CERTIFICATE IS NOT TRANSFERABLE ON CHANGE OF OWNERSHIP, CONTROL, LOCATION, OR BUSINESS ACTIVITY, AND IT IS NOT VALID AFTER THE EXPIRATION DATE.

Form DEA-223 (9/2016)

Arkansas State Board of Pharmacy

322 South Main Street, Suite 600, Little Rock, Arkansas 72201

2016 - 2017 RETAIL PHARMACY LICENSE

D&D Pharmacy, LLC

located at:

8908 Kanis Road, Suite 350, Little Rock, AR 72205

License #: [REDACTED] **Expires: 12/31/2017**

Original License Date: 04/27/2016

This is to certify that the Pharmacy named above is licensed under the provisions of the Arkansas Pharmacy Practice Act, other Arkansas statutes, and Arkansas Pharmacy Regulations.

Pharmacist in Charge: Lashica Antranetta Davis, PD13431

This permit is not transferable and must be prominently displayed.

License #: [REDACTED]

Facility ID: 106994

Arkansas State Board of Pharmacy

Mailing Address: D&D Pharmacy, LLC
P.O. Box 55210
Little Rock, AR 72215

Reason Mailed:

The address above is the mailing address where all correspondence from the board will be sent, including renewal information. All changes to contact information can be made online at www.pharmacyboard.arkansas.gov under "License Maintenance." Use the license number and facility ID above to log in. In-state pharmacies can also update employees online.



Advancing Excellence

**Accredited
Laboratory**



The College of American Pathologists

certifies that the laboratory named below

***Pathology Partners LLC
Laboratory
Little Rock, Arkansas
Nicole A. Massoll, MD***

LAP Number: 8005607
AU-ID: 1617660
CLIA Number: 04D2015800

has met all applicable standards for accreditation and is hereby accredited by the College of American Pathologists' Laboratory Accreditation Program. Reinspection should occur prior to May 4, 2016 to maintain accreditation.

Accreditation does not automatically survive a change in director, ownership, or location and assumes that all interim requirements are met.

Chair, Commission on Laboratory Accreditation

President, College of American Pathologists

Section B - Professional Licensure

CENTERS FOR MEDICARE & MEDICAID SERVICES
CLINICAL LABORATORY IMPROVEMENT AMENDMENTS

CERTIFICATE OF ACCREDITATION

LABORATORY NAME AND ADDRESS

PATHOLOGY PARTNERS LLC
11904 KANIS RD STE H7
LITTLE ROCK, AR 72211

CLIA ID NUMBER

04D2015800

EFFECTIVE DATE

06/20/2016

LABORATORY DIRECTOR

EXPIRATION DATE

CHUN Y FAN M.D.

06/19/2018

Pursuant to Section 353 of the Public Health Services Act (42 U.S.C. 263a) as revised by the Clinical Laboratory Improvement Amendments (CLIA), the above named laboratory located at the address shown hereon (and other approved locations) may accept human specimens for the purposes of performing laboratory examinations or procedures.

This certificate shall be valid until the expiration date above, but is subject to revocation, suspension, limitation, or other sanctions for violation of the Act or the regulations promulgated thereunder.



Karen W. Dyer, Acting Director
Division of Laboratory Services
Survey and Certification Group
Center for Clinical Standards and Quality

408 Certs2_052416

If you currently hold a Certificate of Compliance or Certificate of Accreditation, below is a list of the laboratory specialties/subspecialties you are certified to perform and their effective date:

<u>LAB CERTIFICATION (CODE)</u>	<u>EFFECTIVE DATE</u>	<u>LAB CERTIFICATION (CODE)</u>	<u>EFFECTIVE DATE</u>
HISTOPATHOLOGY (610)	06/20/2012		

FOR MORE INFORMATION ABOUT CLIA, VISIT OUR WEBSITE AT WWW.CMS.GOV/CLIA
OR CONTACT YOUR LOCAL STATE AGENCY. PLEASE SEE THE REVERSE FOR
YOUR STATE AGENCY'S ADDRESS AND PHONE NUMBER.
PLEASE CONTACT YOUR STATE AGENCY FOR ANY CHANGES TO YOUR CURRENT CERTIFICATE.

**CENTERS FOR MEDICARE & MEDICAID SERVICES
CLINICAL LABORATORY IMPROVEMENT AMENDMENTS
CERTIFICATE OF COMPLIANCE**

LABORATORY NAME AND ADDRESS
PATHOLOGY PARTNERS TOXICOLOGY DIVISION
11908 KANIS RD, SUITE G8
LITTLE ROCK, AR 72211

CLIA ID NUMBER
04D2059764

EFFECTIVE DATE
09/03/2016

LABORATORY DIRECTOR
CHUN YANG FAN M.D.

EXPIRATION DATE
09/02/2018

Pursuant to Section 353 of the Public Health Services Act (42 U.S.C. 263a) as revised by the Clinical Laboratory Improvement Amendments (CLIA), the above named laboratory located at the address shown hereon (and other approved locations) may accept human specimens for the purposes of performing laboratory examinations or procedures.
This certificate shall be valid until the expiration date above, but is subject to revocation, suspension, limitation, or other sanctions for violation of the Act or the regulations promulgated thereunder.



Karen W. Dyer
Karen W. Dyer, Acting Director
Division of Laboratory Services
Survey and Certification Group
Center for Clinical Standards and Quality

219 Certs2_091316

If you currently hold a Certificate of Compliance or Certificate of Accreditation, below is a list of the laboratory specialties/subspecialties you are certified to perform and their effective date:

<u>LAB CERTIFICATION (CODE)</u>	<u>EFFECTIVE DATE</u>	<u>LAB CERTIFICATION (CODE)</u>	<u>EFFECTIVE DATE</u>
TOXICOLOGY (340)	09/03/2014		

FOR MORE INFORMATION ABOUT CLIA, VISIT OUR WEBSITE AT WWW.CMS.GOV/CLIA
OR CONTACT YOUR LOCAL STATE AGENCY. PLEASE SEE THE REVERSE FOR
YOUR STATE AGENCY'S ADDRESS AND PHONE NUMBER.
PLEASE CONTACT YOUR STATE AGENCY FOR ANY CHANGES TO YOUR CURRENT CERTIFICATE.

**Section B - Criminal History
Report**

ARKANSAS STATE POLICE

Arkansas Criminal History Report

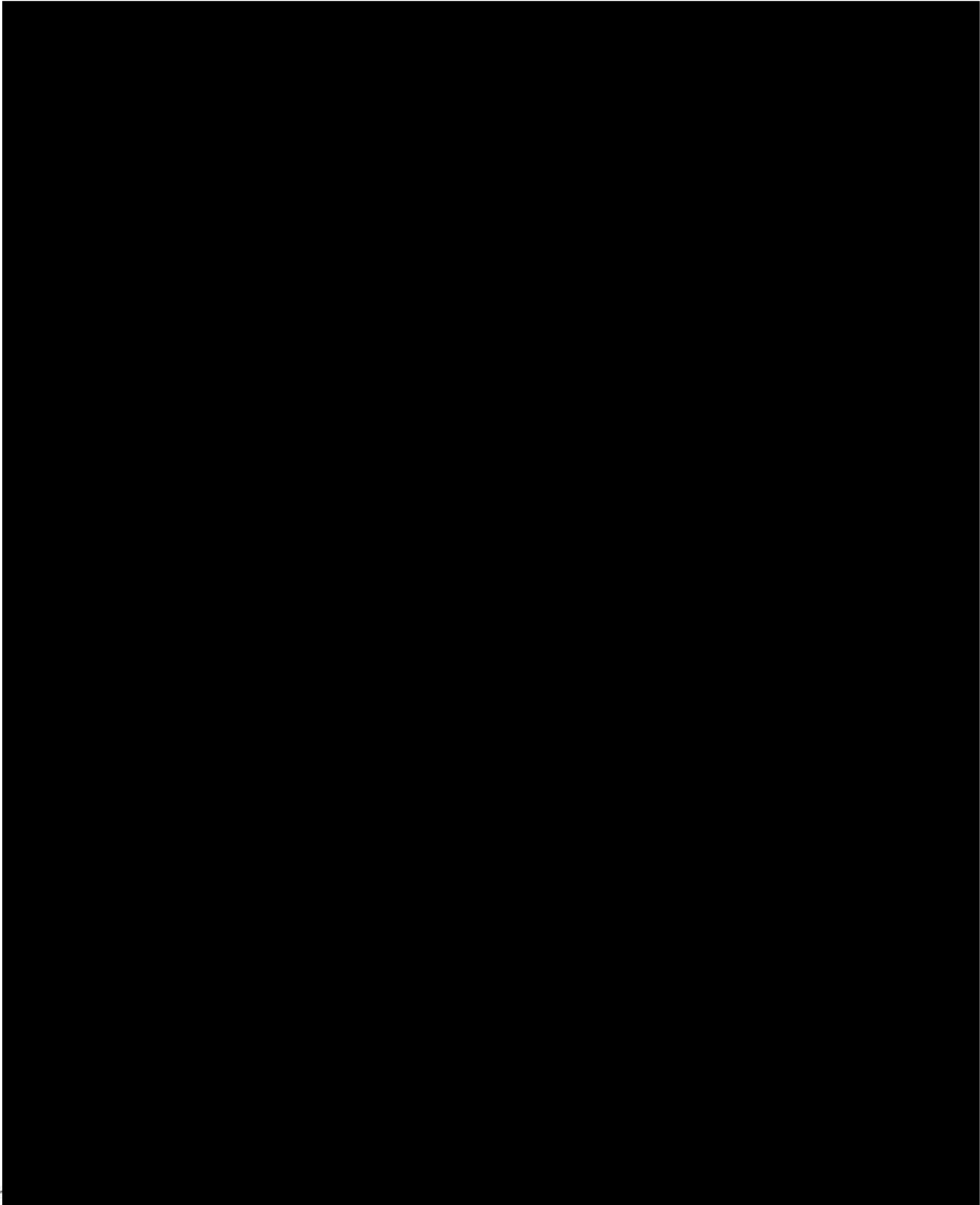

APPLICATION FOR MEDICAL MARIJUANA CULTIVATION FACILITY

SECTION B. Applicant, Owner, Officer, or Board Member Disclosure Statement

Identify your affiliation with the proposed cultivation facility (Applicant, Owner, Officer, Board Member?) Include your percentage of equity ownership in the facility, if any.

Affiliation: Owner

Percentage of Equity Ownership: 4.23%

Legal Name

*In addition to the information below, you are required to provide supporting documents to prove your legal name. See Section B, Appendix 1 for acceptable forms of proof.

Last Name Peck

First Name Clifton

Middle Name Bolen

Maiden Name (if applicable) _____

Alias(es) or former names Cliff

SSN [REDACTED]

Date of Birth

*In addition to providing your date of birth, you are required to provide supporting documents to prove your date of birth. See Section B, Appendix 2 for acceptable forms of proof.

Date of Birth [REDACTED]

Contact Information

Mailing Address [REDACTED]

Phone Number (primary contact number) [REDACTED]

Email Address peckdvm@yahoo.com

Residency

Are you an Arkansas resident? Yes

If you are not an Arkansas resident, please identify your primary place of residence.

Have you been an Arkansas resident for the past seven (7) years? Yes

If you answered “yes” to the question above, in addition to providing the information requested below, you are required to provide supporting documents to prove your residency for the past seven (7) years. See Section B, Appendix 3 for acceptable forms of proof.

Provide the address of your primary residence(s) for the past seven (7) years. Identify the dates (month and year) you resided at each listed location:

[REDACTED] 72223 09/2001 - Present

Tax Liability

Do you have any outstanding tax delinquencies owed to the State of Arkansas: No

If you answered “yes” to the previous question, please explain the nature of any delinquencies:

Other Financial Liabilities

Are you a party to any legal proceedings where damages, fines, or civil penalties may reasonably be expected to exceed \$500,000 above any insurance coverage available to cover the claim?

No

If the answer to the above question is “yes”, attach a statement describing the litigation, including the title and docket number of the litigation, the name and location of the court in which it is pending, the identity of all parties to the litigation, the general nature of the claims being made and the impact an unfavorable opinion may have on your ability to finance and operate the proposed cultivation facility. Any documents submitted in response to this requirement must be labeled with “Section B, Other Financial Liabilities”.

Regulatory History

Have you, or has any entity over which you exercised management or control, ever had any fines or other penalties over \$10,000 assessed by any regulatory agency? **No**

If the answer above is “yes”, attach a statement providing the details of such fines or penalties. Any documents submitted in response to this requirement must be labeled with “Section B, Regulatory History”.

Professional Licensure

Do you presently hold any type of professional license? **Yes**

If yes, identify the type of license and license number **DEA #** [REDACTED]

Is the license in good standing? **Yes**

Certification

I, Clifton Bolen Peck IV, certify that the information provided in this form and its attachments is complete and accurate. I understand that any misstatement or concealment of fact may be grounds for refusal of application or revocation of license if later disclosed.

Signed this 31 day of July, 2017.



Signature of Applicant, Owner, Officer, or Board Member

Subscribed and sworn to before me this 31st day of July, 2017.

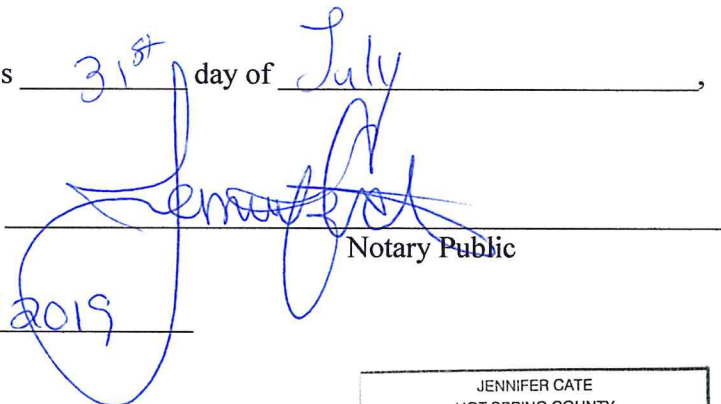

Notary Public

My Commission Expires: 4/6/2019

JENNIFER CATE
HOT SPRING COUNTY
NOTARY PUBLIC - ARKANSAS
My Commission Expires April 06, 2019
Commission No. 12370686

Section B, Appendix 2

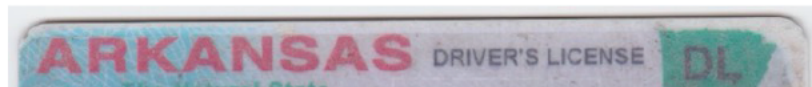

Parcel History Report

Section B, Appendix 3

Created: 8/3/2017 7:45:53 PM

Basic Information	
Parcel Number:	53R0320002501
County Name:	Pulaski County
Owners Name:	PECK CHILDREN TRUST
Billing Name:	PECK CHILDREN TRUST
Billing Address:	[REDACTED]
City, State, Zip:	[REDACTED]

Assessment History					
Year	Assessed Land	Assessed Building	Total Assessed	Taxable Value	
2017	12,600	77,040	89,640	62,545	
2017	10,540	72,970	83,510	62,245	
2016	10,540	72,970	83,510	59,285	
2015	10,540	72,970	83,510	56,915	
2014	10,540	72,970	83,510	54,545	
2013	10,540	72,970	83,510	52,175	
2012	10,540	72,970	83,510	49,805	
2012	10,540	72,970	83,510	52,175	
2011	24,300	51,100	75,400	45,465	
2011	24,300	51,100	75,400	47,435	
2010	24,300	51,100	75,400	43,485	
2009	46,260	59,885	106,145	106,145	
2008	46,264	0	46,264	39,535	
2007	46,264	0	46,264	39,536	
2006	46,264	62,480	108,744	39,537	
2005	15,243	24,297	39,540	39,539	
2004	269	63,750	64,019	280	
2002	239	0	239	239	

Ownership History						
Date	Price	Grantor	Grantee	Book	Page	Deed Type
6/14/2005	0	PECK TR TO PECK FM LTD PTN LLL		05	050267	TRD (Treasurer's Deed)
5/3/2005	0	PECK TR TO PECK RV TR		05	037695	TRD (Treasurer's Deed)
4/26/2001	1	PECK TO TRUST		01	030328	QCD ()
12/1/1990	1			90	70087	DEED (Deed)

State of Arkansas }
 } *Scilicet:*
County of Pulaski }

Sworn Affidavit of

Beverly Joyce Peck being first duly sworn and put upon oath to tell the truth, deposeseth and sayeth as follow:

- My name is Beverly Joyce Peck and I am an individual over the age of eighteen (18) years, competent to make this affidavit. I make this affidavit based upon my personal knowledge of the facts contained herein.
- I am the Trustee of The Peck Children Trust which owns property located at [REDACTED] (the "Property").
- I am personally familiar with Clifton Bolen Peck, who has lived at the Property from September 2001 until Present. He has used the Property as his primary residence during this time.

AND FURTHER AFFIANT SAYETH NOT.

SIGNATURE:

Beverly Joyce Peck Trustee
Beverly Joyce Peck, Trustee, The Peck
Children Trust, Affiant

Verification

Before me personally appeared the affiant, *Beverly Joyce Peck*, to me well known or successfully proven to be the person stated above, who indicated that he/she has executed the foregoing affidavit under oath and for the purposes stated herein, this *13th* day of *September*, 2017.

IN WITNESS WHEREOF, I have hereunder set my hand and official seal as a notary public in and for the State of Arkansas.

Jennifer Cate
NOTARY PUBLIC

My commission expires: *4/6/19*



Individual Voting History Report

Peck, Clifton B IV



Certified This 12th Day of September 2017
By Rebecca D. Lynn
Deputy Clerk



Deputy Clerk

Counted this _____ Day of _____ 20__



Section B - Professional Licensure

CONTROLLED SUBSTANCE REGISTRATION CERTIFICATE
 UNITED STATES DEPARTMENT OF JUSTICE
 DRUG ENFORCEMENT ADMINISTRATION
 WASHINGTON, D.C. 20537

Sections 304 and 1008 (21 U.S.C. 824 and 958) of the Controlled Substances Act of 1970, as amended, provide that the Attorney General may revoke or suspend a registration to manufacture, distribute, dispense, import or export a controlled substance.

DEA REGISTRATION NUMBER: [REDACTED] THIS REGISTRATION EXPIRES: 03-31-2002 FEE PAID: \$210.00

SCHEDULES: 2,2N,3,3N,4,5 BUSINESS ACTIVITY: PRACTITIONER ISSUE DATE: 07-28-2000

PECK, CLIFTON B IV DVM
 DOUBLETREE VETERINARY CLINIC
 2606 FERNDAL CUT OFF RD
 LITTLE ROCK, AR 72223

CORRECTED CERTIFICATE *
 (NOT A RENEWAL)

THIS CERTIFICATE IS NOT TRANSFERABLE ON CHANGE OF OWNERSHIP, CONTROL, LOCATION, BUSINESS ACTIVITY, OR VALID AFTER THE EXPIRATION DATE.

DRUG ENFORCEMENT ADMINISTRATION
 WASHINGTON, D.C. 20537

Sections 304 and 1008 (21 U.S.C. 824 and 958) of the Controlled Substances Act of 1970, as amended, provide that the Attorney General may revoke or suspend a registration to manufacture, distribute, dispense, import or export a controlled substance.

DEA REGISTRATION NUMBER: BP6170663 THIS REGISTRATION EXPIRES: 03-31-2005 FEE PAID: \$210.00

SCHEDULES: 2,2N,3,3N,4,5 BUSINESS ACTIVITY: PRACTITIONER ISSUE DATE: 03-19-2002

PECK, CLIFTON B IV DVM
 DOUBLETREE VETERINARY CLINIC
 2606 FERNDAL CUT OFF RD
 LITTLE ROCK, AR 72223

THIS CERTIFICATE IS NOT TRANSFERABLE ON CHANGE OF OWNERSHIP, CONTROL, LOCATION, BUSINESS ACTIVITY, OR VALID AFTER THE EXPIRATION DATE.

DEA REGISTRATION NUMBER: [REDACTED] THIS REGISTRATION EXPIRES: 03-31-2008 FEE PAID: FEE PAID

SCHEDULES: 2,2N,3,3N,4,5 BUSINESS ACTIVITY: PRACTITIONER ISSUE DATE: 03-16-2005

PECK, CLIFTON B IV DVM
 DOUBLETREE VETERINARY CLINIC
 2606 FERNDAL CUT OFF RD
 LITTLE ROCK, AR 72223-0000

ADDRESS CHANGE REQUEST BP6170663
 PECK, CLIFTON B IV DVM

New Address: _____

City: _____ State: _____ Zip Code: _____

Signature: _____ Date: _____

See back for additional information.

DEA REGISTRATION NUMBER: [REDACTED] THIS REGISTRATION EXPIRES: 03-31-2011 FEE PAID: FEE PAID

SCHEDULES: 2,2N,3,3N,4,5 BUSINESS ACTIVITY: PRACTITIONER ISSUE DATE: 04-01-2008

PECK, CLIFTON B IV DVM
 DOUBLETREE VETERINARY CLINIC
 2606 FERNDAL CUT OFF RD
 LITTLE ROCK, AR 72223-0000

CONTROLLED SUBSTANCE REGISTRATION CERTIFICATE
 UNITED STATES DEPARTMENT OF JUSTICE
 DRUG ENFORCEMENT ADMINISTRATION
 WASHINGTON D.C. 20537

Sections 304 and 1008 (21 USC 824 and 958) of the Controlled Substances Act of 1970, as amended, provide that the Attorney General may revoke or suspend a registration to manufacture, distribute, dispense, import or export a controlled substance.

THIS CERTIFICATE IS NOT TRANSFERABLE ON CHANGE OF OWNERSHIP, CONTROL, LOCATION, OR BUSINESS ACTIVITY, AND IT IS NOT VALID AFTER THE EXPIRATION DATE.

DEA REGISTRATION NUMBER: [REDACTED] THIS REGISTRATION EXPIRES: 03-31-2014 FEE PAID: \$551

SCHEDULES: 2,2N,3,3N,4,5 BUSINESS ACTIVITY: PRACTITIONER ISSUE DATE: 04-07-2011

PECK, CLIFTON B IV DVM
 DOUBLETREE VETERINARY CLINIC
 2606 FERNDAL CUT OFF ROAD
 LITTLE ROCK, AR 72223-0000

CONTROLLED SUBSTANCE-REGULATED CHEMICAL REGISTRATION CERTIFICATE
 UNITED STATES DEPARTMENT OF JUSTICE
 DRUG ENFORCEMENT ADMINISTRATION
 WASHINGTON D.C. 20537

Sections 304 and 1008 (21 USC 824 and 958) of the Controlled Substances Act of 1970, as amended, provide that the Attorney General may revoke or suspend a registration to manufacture, distribute, dispense, import or export a controlled substance.

THIS CERTIFICATE IS NOT TRANSFERABLE ON CHANGE OF OWNERSHIP, CONTROL, LOCATION, OR BUSINESS ACTIVITY, AND IT IS NOT VALID AFTER THE EXPIRATION DATE.

DEA REGISTRATION NUMBER: [REDACTED] THIS REGISTRATION EXPIRES: 03-31-2017 FEE PAID: \$731

SCHEDULES: 2,2N,3,3N,4,5 BUSINESS ACTIVITY: PRACTITIONER ISSUE DATE: 03-28-2014

PECK, CLIFTON B IV DVM
 DOUBLETREE VETERINARY CLINIC
 2606 FERNDAL CUT OFF ROAD
 LITTLE ROCK, AR 72223-0000

CONTROLLED SUBSTANCE REGISTRATION CERTIFICATE
 UNITED STATES DEPARTMENT OF JUSTICE
 DRUG ENFORCEMENT ADMINISTRATION
 WASHINGTON D.C. 20537

Sections 304 and 1008 (21 USC 824 and 958) of the Controlled Substances Act of 1970, as amended, provide that the Attorney General may revoke or suspend a registration to manufacture, distribute, dispense, import or export a controlled substance.

THIS CERTIFICATE IS NOT TRANSFERABLE ON CHANGE OF OWNERSHIP, CONTROL, LOCATION, OR BUSINESS ACTIVITY, AND IT IS NOT VALID AFTER THE EXPIRATION DATE.

DEA REGISTRATION NUMBER: [REDACTED] THIS REGISTRATION EXPIRES: 03-31-2020 FEE PAID: \$731.00

SCHEDULES: 2,2N,3,3N,4,5 BUSINESS ACTIVITY: PRACTITIONER ISSUE DATE: 02-22-2017

PECK, CLIFTON B IV DVM
 DOUBLETREE VETERINARY CLINIC
 2606 FERNDAL CUT OFF ROAD
 LITTLE ROCK, AR 72223

CONTROLLED SUBSTANCE REGISTRATION CERTIFICATE
 UNITED STATES DEPARTMENT OF JUSTICE
 DRUG ENFORCEMENT ADMINISTRATION
 WASHINGTON D.C. 20537

Sections 304 and 1008 (21 USC 824 and 958) of the Controlled Substances Act of 1970, as amended, provide that the Attorney General may revoke or suspend a registration to manufacture, distribute, dispense, import or export a controlled substance.

THIS CERTIFICATE IS NOT TRANSFERABLE ON CHANGE OF OWNERSHIP, CONTROL, LOCATION, OR BUSINESS ACTIVITY, AND IT IS NOT VALID AFTER THE EXPIRATION DATE.

Section B - Professional Licensure

This is to certify that

Clifton B. Peck, IV

has complied with all of the requirements and in acknowledgment of these services is hereby granted this diploma by

Louisiana State University Student Chapter

of the

American Veterinary Medical Association

In testimony whereof are affixed the names of the proper officers and seal of the Association this 12th day of May A.D. 1997.



David L. Kuykendall
Dean

Mary Beth Leisinger
President, American Veterinary Medical Association

Sammy M. Robert
President, Student Chapter

David J. Hillman
Faculty Advisor

Crossie A. Hill
Secretary, Student Chapter

Section B - Professional Licensure

Arkansas Board of Veterinary Medical Examiners

Certificate of License No. 2362

We, the BOARD OF VETERINARY MEDICAL EXAMINERS, of the State of Arkansas do hereby certify that we have this day examined

Clifton B. Peck, IV, D.V.M.

A graduate of Louisiana State University

and find him/her qualified and entitled to receive a CERTIFICATE OF LICENSE to practice

Veterinary Medicine and Surgery

in the State under Acts of the General Assembly of 1975.

Given under our hand and the Seal of the Board of Veterinary Medical Examiners of the State of Arkansas, at

Little Rock, Arkansas, this 9th day of July, 19 97

Ronald L. Mayfield, DVM
SECRETARY-TREASURER

R. Douglas Lester
CHAIRMAN



Section B - Professional Licensure

The MEMS Pinnacle Award

Dr. Cliff Peck, D.V.M.

In recognition of your outstanding performance as a member of the MEMS STAR team which provided the medical support for Operation Delta Blues on October 4th, 2011, the largest operation of its kind ever conducted by the FBI within the United States. During this operation which involved over 700 federal, state and local law enforcement officers, you successfully executed this comprehensive medical mission in direct support of simultaneous police tactical operations conducted over a multi-county area which resulted in the arrest of over 65 suspects and included the rapid treatment and medical evacuation of a police officer injured by gunfire. Your conduct, professional skills and dedication reflect great credit upon MEMS and the entire EMS profession. Well done.

Scott Gordon, LRAA Chair

Jon Swanson, Executive Director

25 October, 2011

Presented to

Cliff Peck, DVM



*In Recognition of Exemplary Service
to the
Federal Bureau of Investigation
in support of "Operation Delta Blues"*

11 October, 2011



*With sincere appreciation for your professionalism,
teamwork and dedication in assuring the safety
and welfare of our canine agents*

Servare Vitas

ARKANSAS STATE POLICE

Arkansas Criminal History Report

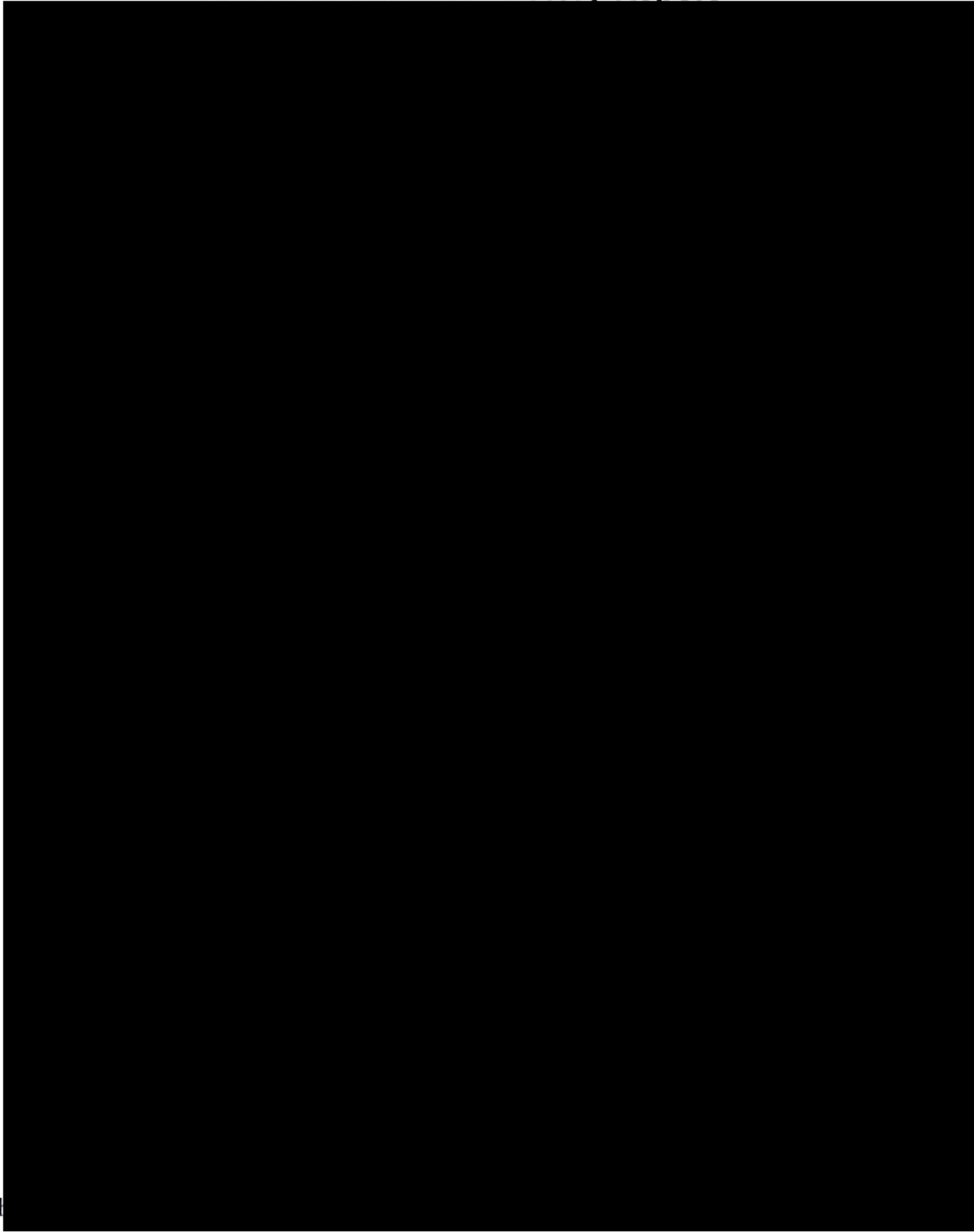

APPLICATION FOR MEDICAL MARIJUANA CULTIVATION FACILITY

SECTION B. Applicant, Owner, Officer, or Board Member Disclosure Statement

Identify your affiliation with the proposed cultivation facility (Applicant, Owner, Officer, Board Member?) Include your percentage of equity ownership in the facility, if any.

Affiliation: Owner

Percentage of Equity Ownership: 4.23%

Legal Name

*In addition to the information below, you are required to provide supporting documents to prove your legal name. See Section B, Appendix 1 for acceptable forms of proof.

Last Name Mooney

First Name Donald

Middle Name Keith

Maiden Name (if applicable) _____

Alias(es) or former names _____

SSN [REDACTED]

Date of Birth

*In addition to providing your date of birth, you are required to provide supporting documents to prove your date of birth. See Section B, Appendix 2 for acceptable forms of proof.

Date of Birth [REDACTED]

Contact Information

Mailing Address [REDACTED]

Phone Number (primary contact number) [REDACTED]

Email Address keith@mooneyone.com

Residency

Are you an Arkansas resident? Yes

If you are not an Arkansas resident, please identify your primary place of residence.

Have you been an Arkansas resident for the past seven (7) years? Yes

If you answered "yes" to the question above, in addition to providing the information requested below, you are required to provide supporting documents to prove your residency for the past seven (7) years. See Section B, Appendix 3 for acceptable forms of proof.

Provide the address of your primary residence(s) for the past seven (7) years. Identify the dates (month and year) you resided at each listed location:

	<u>May 1994 - Present</u>

Tax Liability

Do you have any outstanding tax delinquencies owed to the State of Arkansas: No

If you answered "yes" to the previous question, please explain the nature of any delinquencies:

Other Financial Liabilities

Are you a party to any legal proceedings where damages, fines, or civil penalties may reasonably be expected to exceed \$500,000 above any insurance coverage available to cover the claim?

No

If the answer to the above question is “yes”, attach a statement describing the litigation, including the title and docket number of the litigation, the name and location of the court in which it is pending, the identity of all parties to the litigation, the general nature of the claims being made and the impact an unfavorable opinion may have on your ability to finance and operate the proposed cultivation facility. Any documents submitted in response to this requirement must be labeled with “Section B, Other Financial Liabilities”.

Regulatory History

Have you, or has any entity over which you exercised management or control, ever had any fines or other penalties over \$10,000 assessed by any regulatory agency? **No**

If the answer above is “yes”, attach a statement providing the details of such fines or penalties. Any documents submitted in response to this requirement must be labeled with “Section B, Regulatory History”.

Professional Licensure

Do you presently hold any type of professional license? **Yes**

If yes, identify the type of license and license number DEA - [REDACTED] / Medical C-6151

Is the license in good standing? **Yes**

Certification

Donated

I, Keith Mooney, certify that the information provided in this form and its attachments is complete and accurate. I understand that any misstatement or concealment of fact may be grounds for refusal of application or revocation of license if later disclosed.

Signed this 30 day of July, 2017.

Donal Keith Mooney
Signature of Applicant, Owner, Officer, or Board Member

Subscribed and sworn to before me this 30th day of July, 2017.

[Signature]
Notary Public

My Commission Expires: 4/6/2019

JENNIFER GATE
HOT SPRING COUNTY
NOTARY PUBLIC - ARKANSAS
My Commission Expires April 06, 2019
Commission No. 12370886

Section B, Appendix 2

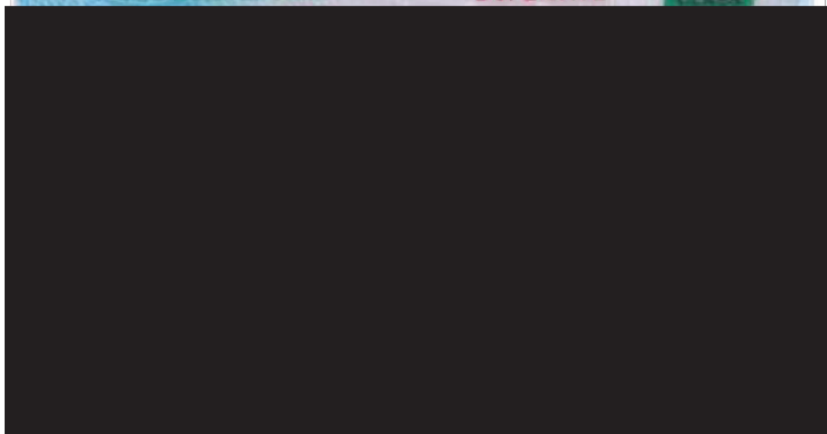
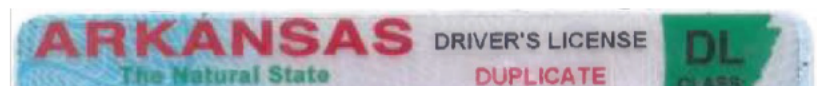

Parcel History Report

Created: 7/30/2017 6:57:23 PM

Basic Information	
Parcel Number:	43L0200101300
County Name:	Pulaski County
Owners Name:	MOONEY FAMILY REVO LIVING TRUST
Billing Name:	MOONEY FAMILY REVO LIVING TRUST
Billing Address:	[REDACTED]
City, State, Zip:	[REDACTED]

Assessment History

Year	Assessed Land	Assessed Building	Total Assessed	Taxable Value
2017	13,600	49,320	62,920	62,920
2012	14,000	47,900	61,900	61,900
2011	12,650	74,047	86,697	86,697
2010	12,650	74,047	86,697	86,697
2009	12,650	74,047	86,697	85,681
2008	11,199	70,402	81,601	92,173
2007	12,650	79,523	92,173	78,054
2006	10,225	64,282	74,507	78,055
2005	11,354	59,606	70,960	70,960
2004	11,000	59,960	70,960	70,960
2002	8,304	0	8,304	8,304

Ownership History

Date	Price	Grantor	Grantee	Book	Page	Deed Type
7/5/2007	0	MOONEY DONALD K/DONNA M	MOONEY FAMILY REVO LIV TR	2007	052506	WADS ()
5/1/1994	309,000			94	38969	DEED (Deed)
4/1/1992	281,000			92	21388	DEED (Deed)
4/1/1991	44,000			91	20241	DEED (Deed)

2007052506
07/06/2007 09:56:17 AM
Filed & Recorded in
Official Records of
PAT O'BRIEN
PULASKI COUNTY
CIRCUIT/COUNTY CLERK
Fees \$14.00

00030721

This Instrument Was Prepared By:
MITCHELL, WILLIAMS, SELIG,
GATES & WOODYARD, P.L.L.C.
425 West Capitol Avenue, Suite 1800
Little Rock, Arkansas 72201-3525

WARRANTY DEED

KNOW ALL PERSONS BY THESE PRESENTS:

THAT WE, **Donald K. Mooney and Donna M. Mooney, GRANTORS**, for and in consideration of the sum of Ten and No/100 dollars (\$10.00) and other valuable consideration, in hand paid by Donald Keith Mooney and Donna Mae Mooney, Trustee of the Mooney Family Revocable Living Trust, created the 2nd day of January, 2002, GRANTEES, the receipt of which is hereby acknowledged, do hereby grant, bargain, sell and convey unto the said Grantees, and unto their successors and assigns forever, the following lands lying in Pulaski County, Arkansas:

SEE EXHIBIT "A" ATTACHED HERETO FOR LEGAL DESCRIPTIONS

Subject to all liens and encumbrances of record.

TO HAVE AND TO HOLD the same unto the said Grantees and unto their successors and assigns forever with all appurtenances thereunto belonging.

And we hereby covenant with the said Grantees that we will forever warrant and defend the title to the said lands against all lawful claims whatever.

And we, for and in consideration of the said sum of money, do hereby release and relinquish unto the said Grantees, and unto their successors and assigns, all of our right and possibility of dower, curtesy and homestead in and to the said lands.

WITNESS our hands on this 5th day of July, 2007.



Donald K. Mooney

Donald K. Mooney

Donna M. Mooney

Donna M. Mooney

Section B, Appendix 3

STATE OF ARKANSAS)
)ss.
COUNTY OF PULASKI)

ACKNOWLEDGMENT

00001722

On this day, before me, the undersigned, a Notary Public, duly commissioned and acting, came Donald K. Mooney and Donna M. Mooney, to me well known as the Grantors in the foregoing deed, and stated that they had executed the same for the consideration, uses and purposes therein mentioned and set forth.

And Grantors declared that they had, of their own free wills, executed said instrument and signed and sealed the relinquishment of dower, curtesy and homestead therein for the consideration and purposes therein contained and set forth, without compulsion or undue influence of the other.

WITNESS my hand and official seal this 5th day of July, 2007.

Tracy Bruce

Notary Public

My Commission Expires:

5-1-11

(SEAL)



952826.1

The undersigned hereby certifies under penalty of false swearing that the legally correct amount of documentary stamps has been placed on this instrument. Exempt or no consideration paid if none shown.

[Signature]

[GRANTEE or GRANTEE's Agent]

GRANTEE's Address:



Section B, Appendix 3

Doc# 2007052506

EXHIBIT "A"

00000728

TRACT 1:



TRACT 2:

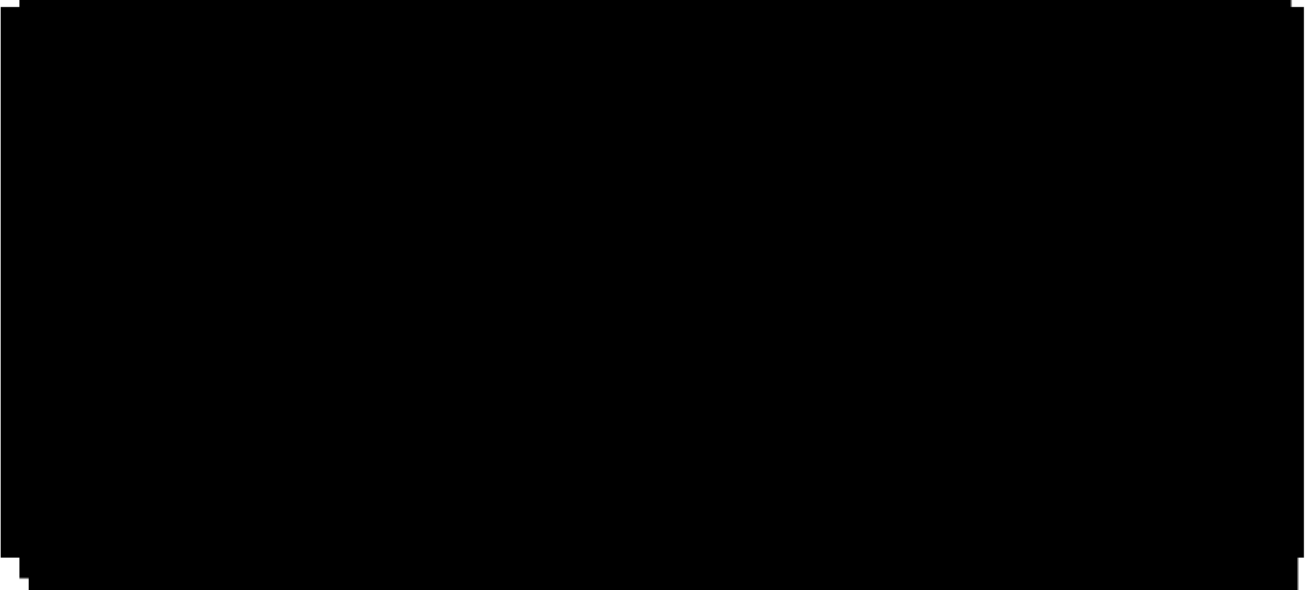

State of Arkansas }
 } *Scilicet:*
County of Pulaski }

Sworn Affidavit of
Dr. Donna Mooney Ph D

Dr. Donna Mooney Ph.D being first duly sworn and put upon oath to tell the truth, depose and sayeth as follow:

1. My name is Dr. Donna Mooney, Ph.D and I am a trustee and beneficiary for the Mooney Family Revocable Living Trust an individual over the age of eighteen (18) years, competent to make this affidavit. I make this affidavit based upon my personal knowledge of the facts contained herein.
2. The Mooney Family Revocable Living Trust owns property located at [REDACTED] (the "Property").
3. I am personally familiar with Dr. Donald Keith Mooney M.D. who was a tenant at the Property from 1985 until present. To the best of my knowledge, he/she used the Property as his/her primary residence during that time.

AND FURTHER AFFIANT SAYETH NOT.

SIGNATURE:



Dr. Donna Mooney Affiant

VERIFICATION

Before me personally appeared the affiant, Dr. Donna Mooney to me well known or successfully proven to be the person stated above, who indicated that he/she has executed the foregoing affidavit under oath and for the purposes stated herein, this 14th day of September, 2017.

IN WITNESS WHEREOF, I have hereunder set my hand and official seal as a notary public in and for the State of Arkansas.



NOTARY PUBLIC

JENNIFER CATE
HOT SPRING COUNTY
NOTARY PUBLIC - ARKANSAS
My Commission Expires April 06, 2019
Commission No. 12370688

My commission expires:
4/6/19

Individual Voting History Report

Mooney, Donald Keith

[REDACTED]
[REDACTED]

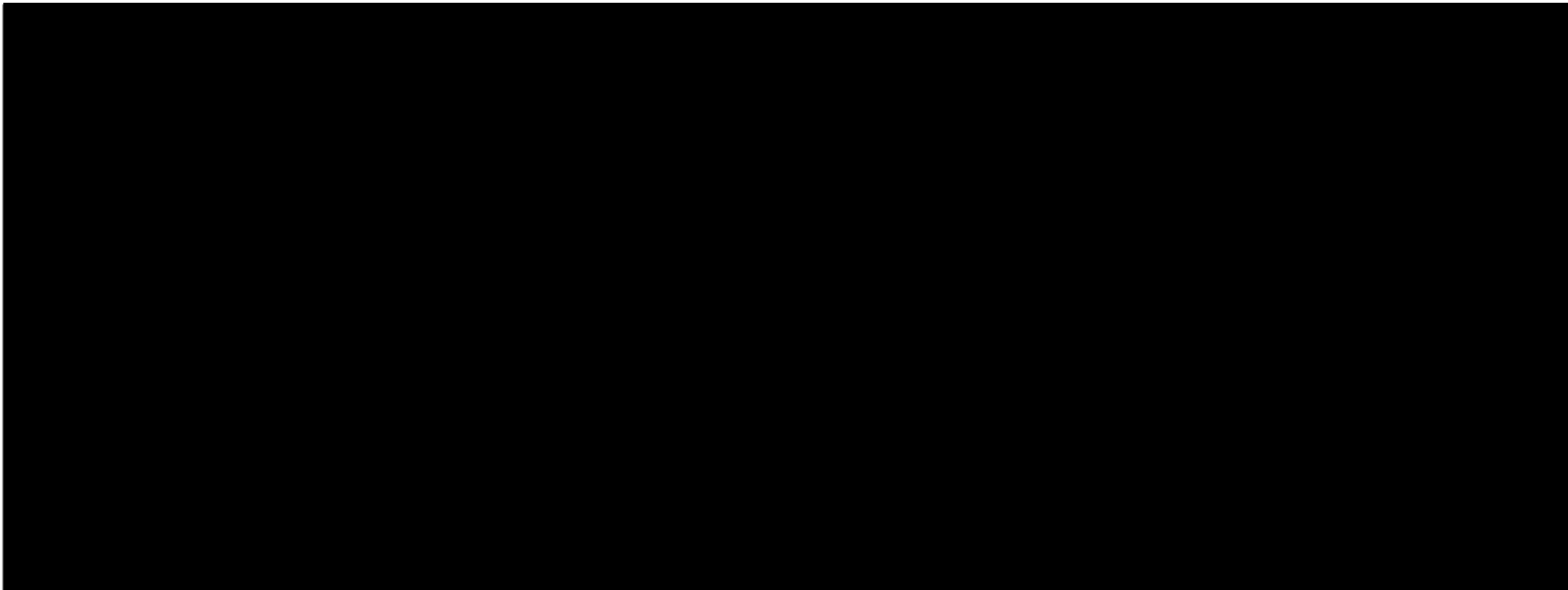

Certified This 12th Day of September 2017

By Rebecca A. Lynn
Deputy Clerk



By _____ Deputy Clerk

Certified True and Correct Copy of _____ 30



Section B - Professional Licensure

DEA REGISTRATION NUMBER [REDACTED]	THIS REGISTRATION EXPIRES 01-31-2020	FEE PAID \$731	CONTROLLED SUBSTANCE REGISTRATION CERTIFICATE UNITED STATES DEPARTMENT OF JUSTICE DRUG ENFORCEMENT ADMINISTRATION WASHINGTON D.C. 20537 Sections 304 and 1008 (21 USC 824 and 958) of the Controlled Substances Act of 1970, as amended, provide that the Attorney General may revoke or suspend a registration to manufacture, distribute, dispense, import or export a controlled substance. THIS CERTIFICATE IS NOT TRANSFERABLE ON CHANGE OF OWNERSHIP, CONTROL, LOCATION, OR BUSINESS ACTIVITY, AND IT IS NOT VALID AFTER THE EXPIRATION DATE.
SCHEDULES 2,2N,3 3N,4,5	BUSINESS ACTIVITY PRACTITIONER	ISSUE DATE 12-28-2016	
MOONEY, DONALD KEITH MD 1300 CENTERVIEW DRIVE LITTLE ROCK, AR 72211			

CONTROLLED SUBSTANCE REGISTRATION CERTIFICATE UNITED STATES DEPARTMENT OF JUSTICE DRUG ENFORCEMENT ADMINISTRATION WASHINGTON D.C. 20537			
DEA REGISTRATION NUMBER [REDACTED]	THIS REGISTRATION EXPIRES 01-31-2020	FEE PAID \$731	Sections 304 and 1008 (21 USC 824 and 958) of the Controlled Substances Act of 1970, as amended, provide that the Attorney General may revoke or suspend a registration to manufacture, distribute, dispense, import or export a controlled substance. THIS CERTIFICATE IS NOT TRANSFERABLE ON CHANGE OF OWNERSHIP, CONTROL, LOCATION, OR BUSINESS ACTIVITY, AND IT IS NOT VALID AFTER THE EXPIRATION DATE.
SCHEDULES 2,2N,3 3N,4,5	BUSINESS ACTIVITY PRACTITIONER	ISSUE DATE 12-28-2016	
MOONEY, DONALD KEITH MD 1300 CENTERVIEW DRIVE LITTLE ROCK, AR 72211			

Form DEA-223 (9/2016)



ARKANSAS STATE MEDICAL BOARD

1401 West Capitol, Suite 340, Little Rock, Arkansas 72201 (501) 296-1802 FAX: (501) 603-3555

www.armedicalboard.org

Section B - Professional Licensure

Detailed License Verification

Queried on: Tuesday, August 01, 2017 at: 3:43 PM

General Information

Name: Donald Keith Mooney, M.D.
Specialty: Urology

Address Information

Mailing Address: 1300 Centerview Drive
City/State/Zip: Little Rock, AR 72211
Phone: (501) 219-8900
Fax: (501) 537-7848

License Information

License Number: C-6151
Original Issue Date: 3/15/1982
Expiration Date: 11/30/2017
Basis: Exam
License Status: Active
License Category: Unlimited

Appearance: No

Reason: Exemption

Date of Action: 8/6/2015

Minutes:

Discussion #15-247. MOONEY, Donald Keith, M.D.; KUHN, Ronald Griffin, M.D.; COUSSENS, David Mark, M.D.; D'ANNA, Richard Emanuel, M.D.; GOODSON, Timothy Carl, M.D.; JONES, Gail Reede, M.D.; STALLINGS, James Walt, M.D.; DIAZ, Edwin A., M.D.; BOZEMAN, Caleb Blythe, M.D.; CLAYBROOK, Kevin Douglas, M.D.; and MOORE, John Taylor, M.D. Upon a motion by Dr. S. Simon, seconded by Dr. J. Weiss, the Board voted unanimously to grant the physicians permits to dispense Zytiga and Xtandi.

Appearance: No

Reason: Exemption

Date of Action: 2/2/2017

Minutes:

Discussion #15-247. LANGFORD, Timothy Dean, M.D.; MOONEY, Donald Keith, M.D.; KUHN, Ronald Griffin, M.D.; COUSSENS, David Mark, M.D.; D'ANNA, Richard Emanuel, M.D.; GOODSON, Timothy Carl, M.D.; JONES, Gail Reede, M.D.; DIAZ, Edwin A., M.D.; BOZEMAN, Caleb Blythe, M.D.; CLAYBROOK, Kevin Douglas, M.D.; MOORE, John Taylor, M.D. Upon a motion by Dr. J. Weiss, seconded by Dr. O. Atiq, the Board voted to grant the physicians' request to add Prednisone to their existing dispensing formulary. There was one vote opposed to this decision.

ARKANSAS STATE POLICE
Arkansas Criminal History Report

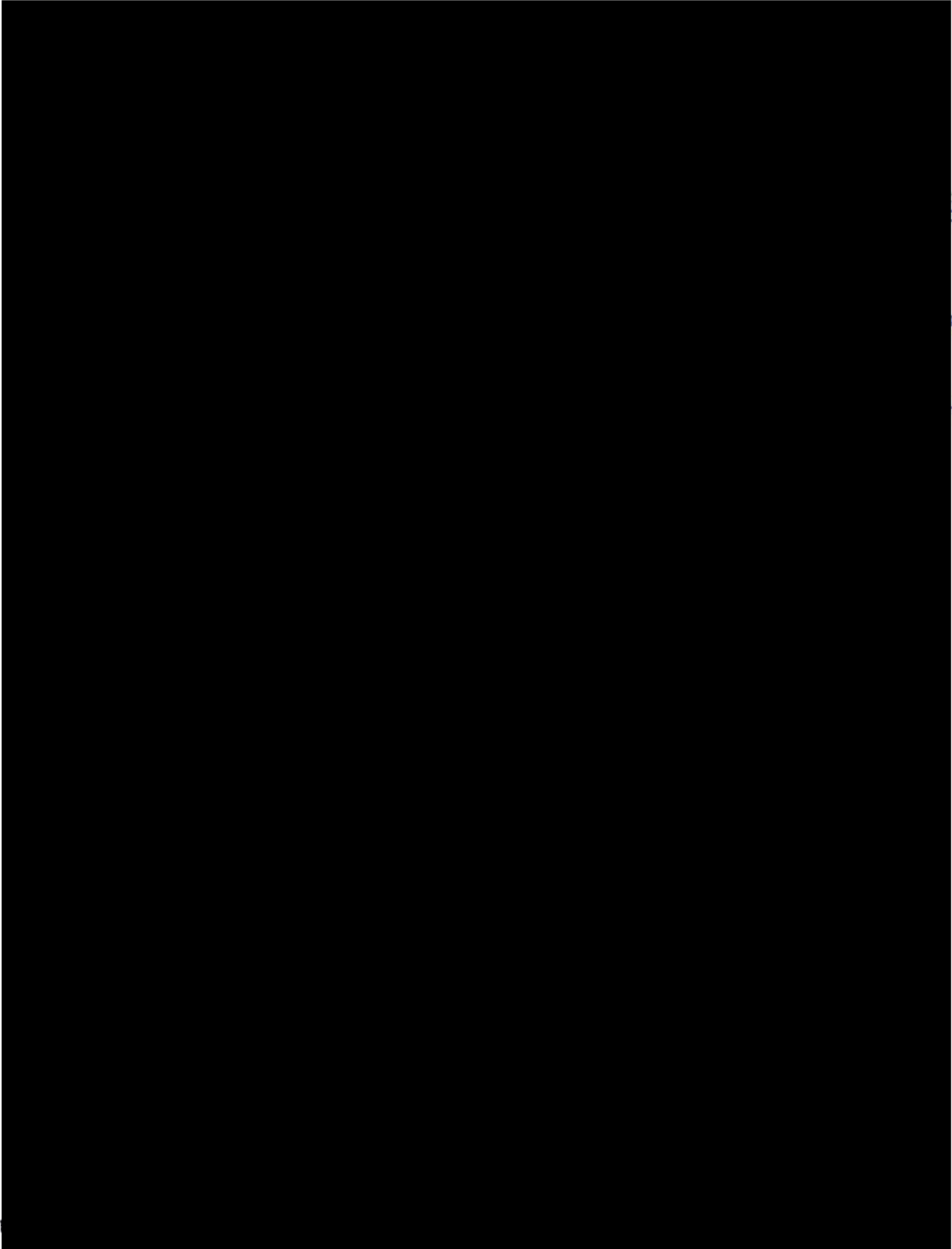

POLICE
N

APPLICATION FOR MEDICAL MARIJUANA CULTIVATION FACILITY

SECTION B. Applicant, Owner, Officer, or Board Member Disclosure Statement

Identify your affiliation with the proposed cultivation facility (Applicant, Owner, Officer, Board Member?) Include your percentage of equity ownership in the facility, if any.

Affiliation: Owner, Vice President - Community Outreach, Board Member

Percentage of Equity Ownership: 1.41%

Legal Name

*In addition to the information below, you are required to provide supporting documents to prove your legal name. See Section B, Appendix 1 for acceptable forms of proof.

Last Name Terrell

First Name Donna

Middle Name Ann

Maiden Name (if applicable) _____

Alias(es) or former names _____

SSN [REDACTED]

Date of Birth

*In addition to providing your date of birth, you are required to provide supporting documents to prove your date of birth. See Section B, Appendix 2 for acceptable forms of proof.

Date of Birth [REDACTED]

Contact Information

Mailing Address [REDACTED]
[REDACTED]

Phone Number (primary contact number) [REDACTED]

Email Address donnaterrell@sbcglobal.net

Residency

Are you an Arkansas resident? Yes

If you are not an Arkansas resident, please identify your primary place of residence.

Have you been an Arkansas resident for the past seven (7) years? Yes

If you answered "yes" to the question above, in addition to providing the information requested below, you are required to provide supporting documents to prove your residency for the past seven (7) years. See Section B, Appendix 3 for acceptable forms of proof.

Provide the address of your primary residence(s) for the past seven (7) years. Identify the dates (month and year) you resided at each listed location:

[REDACTED] - March 2011 to Present
[REDACTED] - June 2010 to March 2011
[REDACTED] - February 2005 - June 2010

Tax Liability

Do you have any outstanding tax delinquencies owed to the State of Arkansas: No

If you answered "yes" to the previous question, please explain the nature of any delinquencies:

Other Financial Liabilities

Are you a party to any legal proceedings where damages, fines, or civil penalties may reasonably be expected to exceed \$500,000 above any insurance coverage available to cover the claim?

No

If the answer to the above question is “yes”, attach a statement describing the litigation, including the title and docket number of the litigation, the name and location of the court in which it is pending, the identity of all parties to the litigation, the general nature of the claims being made and the impact an unfavorable opinion may have on your ability to finance and operate the proposed cultivation facility. Any documents submitted in response to this requirement must be labeled with “Section B, Other Financial Liabilities”.

Regulatory History

Have you, or has any entity over which you exercised management or control, ever had any fines or other penalties over \$10,000 assessed by any regulatory agency? **No**

If the answer above is “yes”, attach a statement providing the details of such fines or penalties. Any documents submitted in response to this requirement must be labeled with “Section B, Regulatory History”.

Professional Licensure

Do you presently hold any type of professional license? **No**

If yes, identify the type of license and license number _____

Is the license in good standing? _____

Certification

I, DONNA TERRELL, certify that the information provided in this form and its attachments is complete and accurate. I understand that any misstatement or concealment of fact may be grounds for refusal of application or revocation of license if later disclosed.

Signed this 2nd day of August, 2017.



Signature of Applicant, Owner, Officer, or Board Member

Subscribed and sworn to before me this 2nd day of August, 2017.

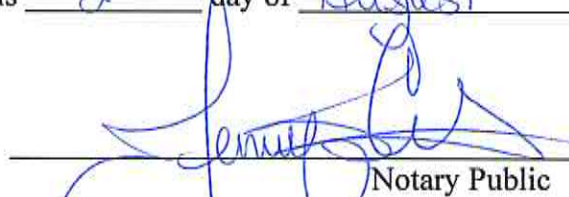

Notary Public

My Commission Expires: 4/6/2019

JENNIFER CATE
HOT SPRING COUNTY
NOTARY PUBLIC - ARKANSAS
My Commission Expires April 06, 2019
Commission No. 12370686

Section B, Appendix 2

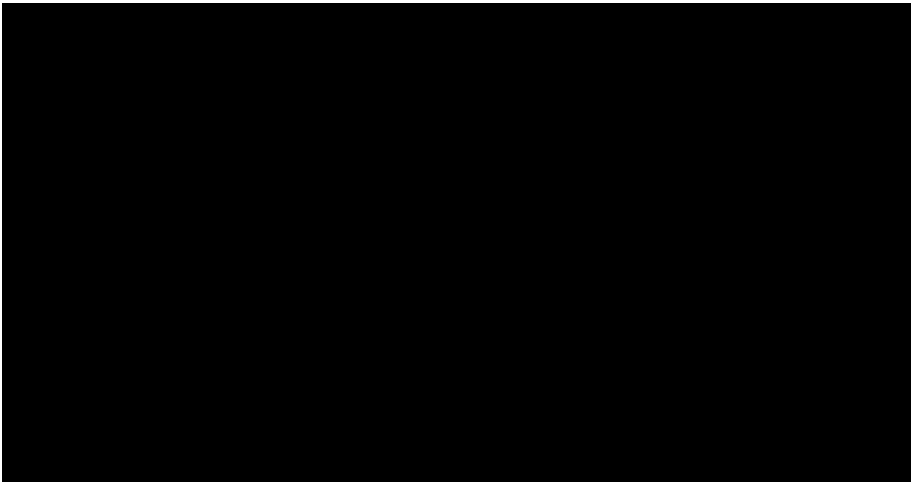
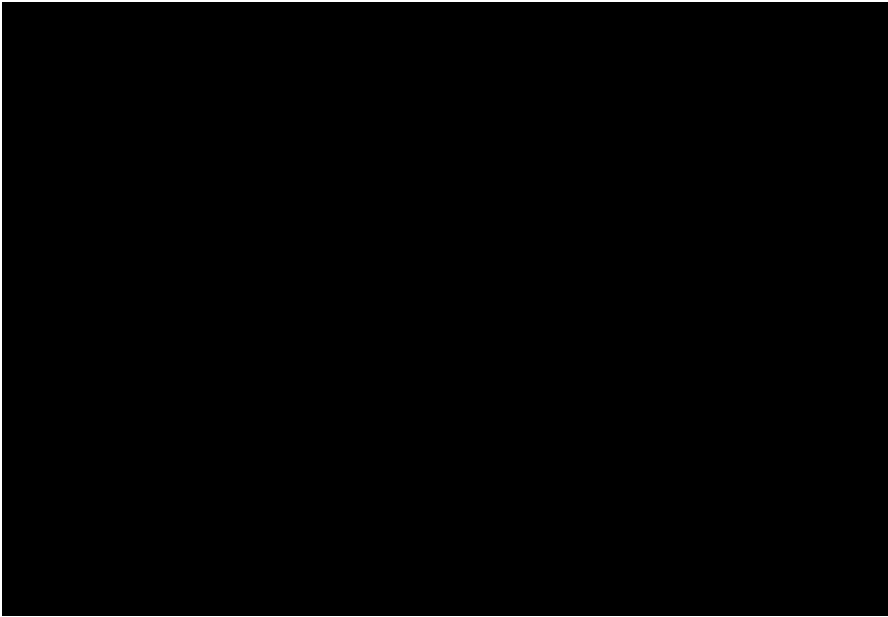

Parcel History Report

Created: 8/2/2017 12:35:52 PM

Basic Information	
Parcel Number:	53L0360300021
County Name:	Pulaski County
Owners Name:	TERRELL DONNA
Billing Name:	TERRELL DONNA
Billing Address:	[REDACTED]
City, State, Zip:	[REDACTED]

Assessment History

Year	Assessed Land	Assessed Building	Total Assessed	Taxable Value
2017	0	54,570	54,570	46,888
2016	0	44,658	44,658	44,658
2016	0	55,600	55,600	55,600
2016	0	57,960	57,960	57,960
2015	0	77,122	77,122	77,122
2015	0	83,540	83,540	83,540
2014	0	77,122	77,122	77,122
2014	0	83,540	83,540	83,540
2013	0	77,122	77,122	77,122
2013	0	83,540	83,540	83,540
2012	0	77,122	77,122	77,122
2012	0	83,540	83,540	83,540
2012	0	86,750	86,750	86,750
2011	0	94,680	94,680	94,680
2011	0	94,680	94,680	94,680
2010	0	40,700	40,700	40,700
2009	7,920	0	7,920	7,920
2008	7,920	0	7,920	7,920

Ownership History

Date	Price	Grantor	Grantee	Book	Page	Deed Type
3/18/2011	0	SIXTH HOLE CONDOS AT CHENAL WO	TERRELL DONNA	2011	023701	CR (Correction Deed)
3/18/2011	415,000	SIXTH HOLE CONDOS AT CHENAL W	TERRELL DONNA	2011	016845	WD (Warranty Deed)
9/13/2007	0			I	154	MAD ()

Individual Voting History Report

Terrell, Donna A

[REDACTED]

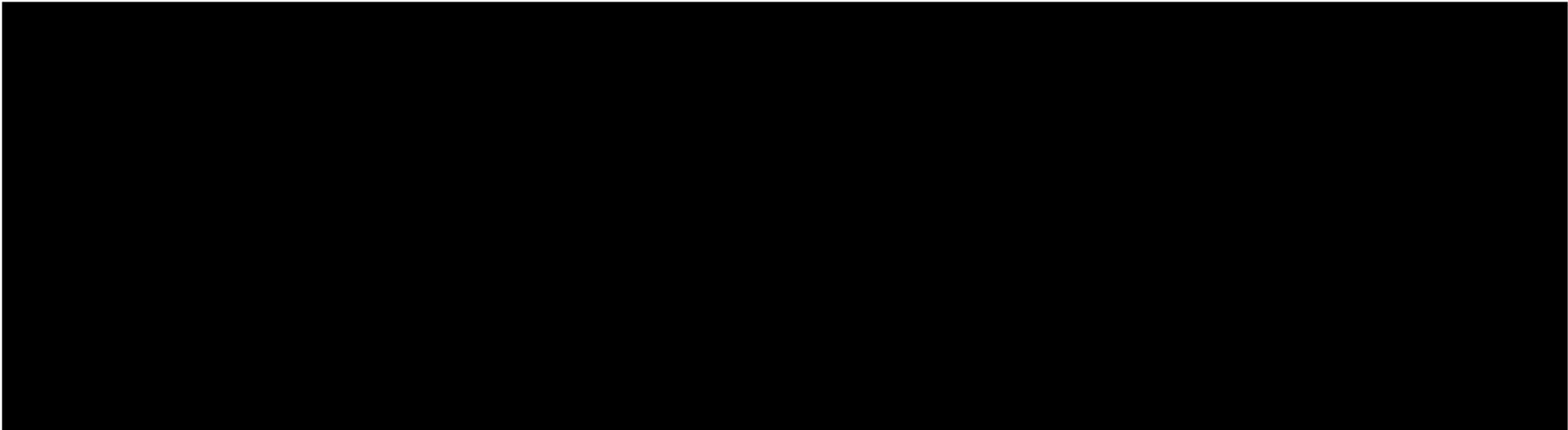

Certified This 12th Day of September 2017
By Rebecca D. Lynn
Deputy Clerk





B) Երևանի քաղաքի Ծածկի Քիմիա

Հանձնարարության Ծանուցումը Ծածկի Քիմիա 50

ARKANSAS STATE POLICE

Arkansas Criminal History Report

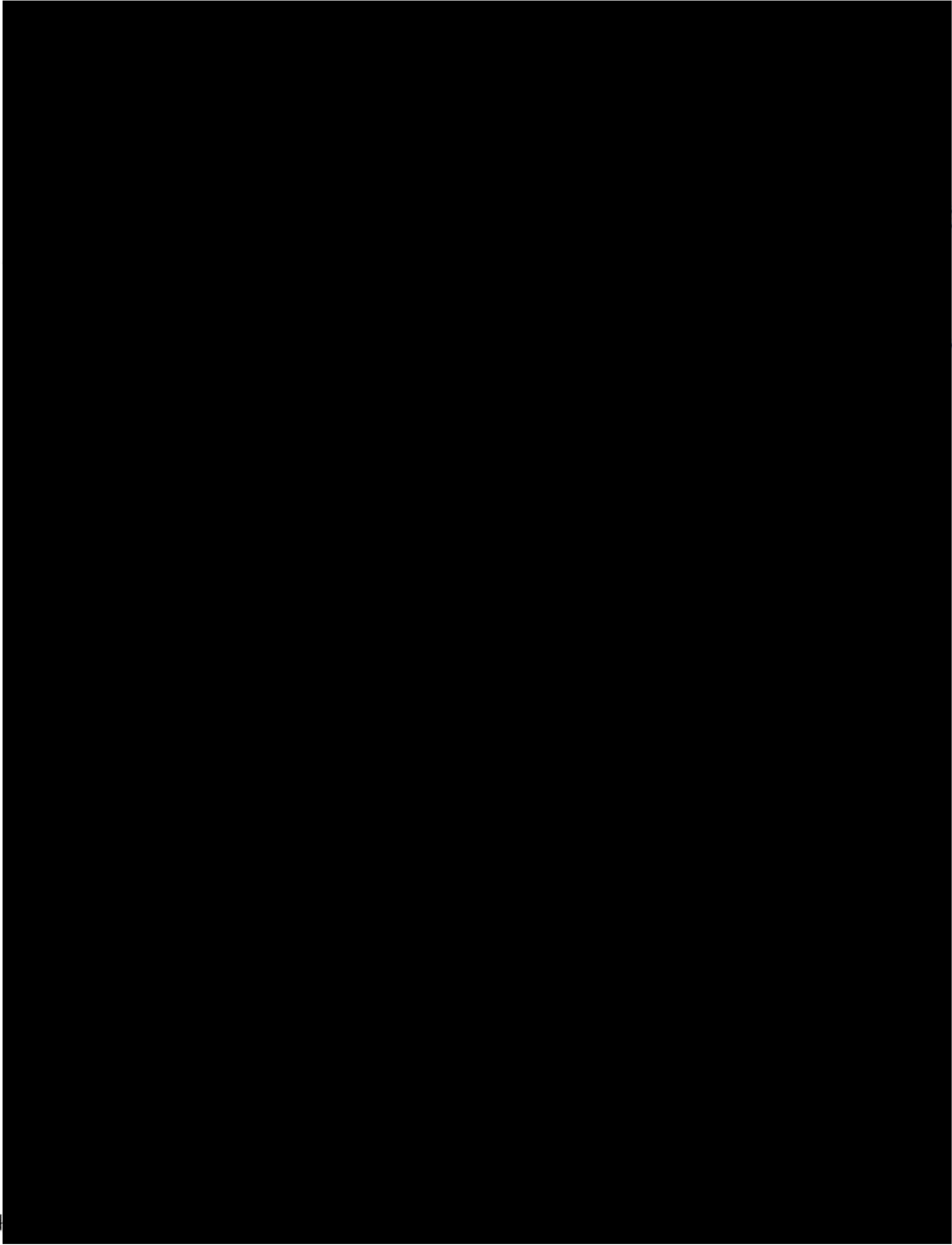

APPLICATION FOR MEDICAL MARIJUANA CULTIVATION FACILITY

SECTION B. Applicant, Owner, Officer, or Board Member Disclosure Statement

Identify your affiliation with the proposed cultivation facility (Applicant, Owner, Officer, Board Member?) Include your percentage of equity ownership in the facility, if any.

Affiliation: Owner, Board Member

Percentage of Equity Ownership: 7.51%

Legal Name

*In addition to the information below, you are required to provide supporting documents to prove your legal name. See Section B, Appendix 1 for acceptable forms of proof.

Last Name Mooney

First Name Donna

Middle Name Mae

Maiden Name (if applicable) Weir

Alias(es) or former names _____

SSN [REDACTED]

Date of Birth

*In addition to providing your date of birth, you are required to provide supporting documents to prove your date of birth. See Section B, Appendix 2 for acceptable forms of proof.

Date of Birth [REDACTED]

Contact Information

Mailing Address [REDACTED]

Phone Number (primary contact number) [REDACTED]

Email Address scs@securecomputingsolutions.com

Residency

Are you an Arkansas resident? Yes

If you are not an Arkansas resident, please identify your primary place of residence.

Have you been an Arkansas resident for the past seven (7) years? Yes

If you answered “yes” to the question above, in addition to providing the information requested below, you are required to provide supporting documents to prove your residency for the past seven (7) years. See Section B, Appendix 3 for acceptable forms of proof.

Provide the address of your primary residence(s) for the past seven (7) years. Identify the dates (month and year) you resided at each listed location:

 - Present

Tax Liability

Do you have any outstanding tax delinquencies owed to the State of Arkansas: No

If you answered “yes” to the previous question, please explain the nature of any delinquencies:

Other Financial Liabilities

Are you a party to any legal proceedings where damages, fines, or civil penalties may reasonably be expected to exceed \$500,000 above any insurance coverage available to cover the claim?

No

If the answer to the above question is “yes”, attach a statement describing the litigation, including the title and docket number of the litigation, the name and location of the court in which it is pending, the identity of all parties to the litigation, the general nature of the claims being made and the impact an unfavorable opinion may have on your ability to finance and operate the proposed cultivation facility. Any documents submitted in response to this requirement must be labeled with “Section B, Other Financial Liabilities”.

Regulatory History

Have you, or has any entity over which you exercised management or control, ever had any fines or other penalties over \$10,000 assessed by any regulatory agency? **No**

If the answer above is “yes”, attach a statement providing the details of such fines or penalties. Any documents submitted in response to this requirement must be labeled with “Section B, Regulatory History”.

Professional Licensure

Do you presently hold any type of professional license? **No**

If yes, identify the type of license and license number _____

Is the license in good standing? _____

Certification

I, Donna M. Mooney, certify that the information provided in this form and its attachments is complete and accurate. I understand that any misstatement or concealment of fact may be grounds for refusal of application or revocation of license if later disclosed.

Signed this 30 day of July, 2017.

Donna M. Mooney
Signature of Applicant, Owner, Officer, or Board Member

Subscribed and sworn to before me this 30th day of July, 2017.

Jennifer Cate
Notary Public

My Commission Expires: 4/6/2019

JENNIFER CATE
HOT SPRING COUNTY
NOTARY PUBLIC - ARKANSAS
My Commission Expires April 08, 2019
Commission No. 12370686

Section B, Appendix 2

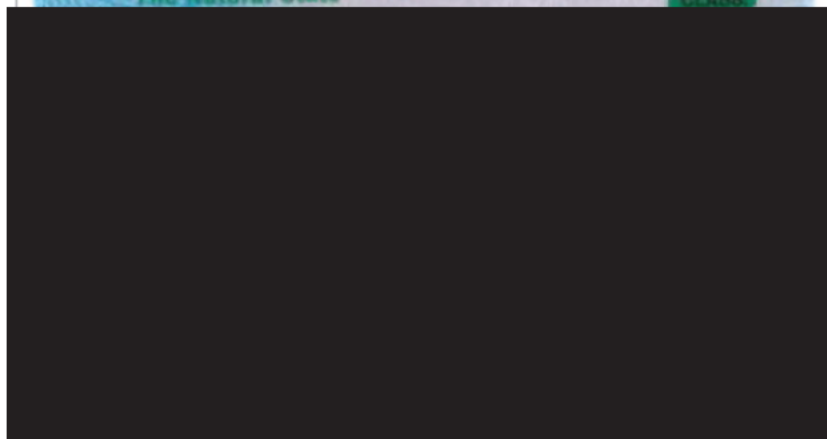
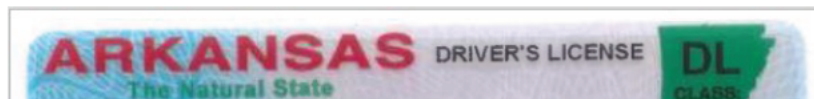

Section B, Appendix 3

Parcel History Report

Created: 7/30/2017 6:57:23 PM

Basic Information	
Parcel Number:	43L0200101300
County Name:	Pulaski County
Owners Name:	MOONEY FAMILY REVO LIVING TRUST
Billing Name:	MOONEY FAMILY REVO LIVING TRUST
Billing Address:	[REDACTED]
City, State, Zip:	[REDACTED]

Assessment History

Year	Assessed Land	Assessed Building	Total Assessed	Taxable Value
2017	13,600	49,320	62,920	62,920
2012	14,000	47,900	61,900	61,900
2011	12,650	74,047	86,697	86,697
2010	12,650	74,047	86,697	86,697
2009	12,650	74,047	86,697	85,681
2008	11,199	70,402	81,601	92,173
2007	12,650	79,523	92,173	78,054
2006	10,225	64,282	74,507	78,055
2005	11,354	59,606	70,960	70,960
2004	11,000	59,960	70,960	70,960
2002	8,304	0	8,304	8,304

Ownership History

Date	Price	Grantor	Grantee	Book	Page	Deed Type
7/5/2007	0	MOONEY DONALD K/DONNA M	MOONEY FAMILY REVO LIV TR	2007	052506	WADS ()
5/1/1994	309,000			94	38969	DEED (Deed)
4/1/1992	281,000			92	21388	DEED (Deed)
4/1/1991	44,000			91	20241	DEED (Deed)

Section B, Appendix 3

2007052506
07/06/2007 09:56:17 AM
Filed & Recorded in
Official Records of
PAT O'BRIEN
PULASKI COUNTY
CIRCUIT/COUNTY CLERK
Fees \$14.00

00030721

This Instrument Was Prepared By:
MITCHELL, WILLIAMS, SELIG,
GATES & WOODYARD, P.L.L.C.
425 West Capitol Avenue, Suite 1800
Little Rock, Arkansas 72201-3525

WARRANTY DEED

KNOW ALL PERSONS BY THESE PRESENTS:

THAT WE, **Donald K. Mooney and Donna M. Mooney, GRANTORS**, for and in consideration of the sum of Ten and No/100 dollars (\$10.00) and other valuable consideration, in hand paid by Donald Keith Mooney and Donna Mae Mooney, Trustee of the Mooney Family Revocable Living Trust, created the 2nd day of January, 2002, GRANTEES, the receipt of which is hereby acknowledged, do hereby grant, bargain, sell and convey unto the said Grantees, and unto their successors and assigns forever, the following lands lying in Pulaski County, Arkansas:

SEE EXHIBIT "A" ATTACHED HERETO FOR LEGAL DESCRIPTIONS

Subject to all liens and encumbrances of record.

TO HAVE AND TO HOLD the same unto the said Grantees and unto their successors and assigns forever with all appurtenances thereunto belonging.

And we hereby covenant with the said Grantees that we will forever warrant and defend the title to the said lands against all lawful claims whatever.

And we, for and in consideration of the said sum of money, do hereby release and relinquish unto the said Grantees, and unto their successors and assigns, all of our right and possibility of dower, curtesy and homestead in and to the said lands.

WITNESS our hands on this 5th day of July, 2007.

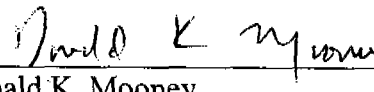

Donald K. Mooney

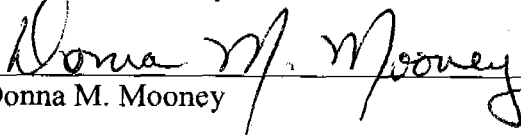

Donna M. Mooney



Section B, Appendix 3

STATE OF ARKANSAS)
)ss.
COUNTY OF PULASKI)

ACKNOWLEDGMENT

00001722

On this day, before me, the undersigned, a Notary Public, duly commissioned and acting, came Donald K. Mooney and Donna M. Mooney, to me well known as the Grantors in the foregoing deed, and stated that they had executed the same for the consideration, uses and purposes therein mentioned and set forth.

And Grantors declared that they had, of their own free wills, executed said instrument and signed and sealed the relinquishment of dower, curtesy and homestead therein for the consideration and purposes therein contained and set forth, without compulsion or undue influence of the other.

WITNESS my hand and official seal this 5th day of July, 2007.

Tracy Bruce

Notary Public

My Commission Expires:

5-1-11

(SEAL)



952826.1

The undersigned hereby certifies under penalty of false swearing that the legally correct amount of documentary stamps has been placed on this instrument. Exempt or no consideration paid if none shown.

[Signature]
[GRANTEE or GRANTEE's Agent]

GRANTEE's Address: [REDACTED]

Section B, Appendix 3

Doc# 2007052506

EXHIBIT "A"

00000728

TRACT 1:



TRACT 2:



Section B, Appendix 3

State of Arkansas }
 } Scilicet:
County of Pulaski }

Sworn Affidavit of
Dr. Donna Mooney Ph D

Dr. Donna Mooney Ph.D being first duly sworn and put upon oath to tell the truth, depose and sayeth as follow:

1. My name is Dr. Donna Mooney, Ph.D and I am a trustee and beneficiary for the Mooney Family Revocable Living Trust an individual over the age of eighteen (18) years, competent to make this affidavit. I make this affidavit based upon my personal knowledge of the facts contained herein.
2. The Mooney Family Revocable Living Trust owns property located at [REDACTED] (the "Property").
3. I am personally familiar with Dr. Donna Mooney who was a tenant at the Property from 1985 until present. To the best of my knowledge, he/she used the Property as his/her primary residence during that time.

AND FURTHER AFFIANT SAYETH NOT.

SIGNATURE:

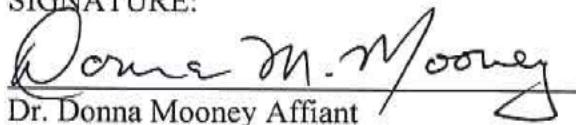
Dr. Donna Mooney Affiant

VERIFICATION

Before me personally appeared the affiant, Dr. Donna Mooney to me well known or successfully proven to be the person stated above, who indicated that he/she has executed the foregoing affidavit under oath and for the purposes stated herein, this 14th day of September, 2017.

IN WITNESS WHEREOF, I have hereunder set my hand and official seal as a notary public in and for the State of Arkansas.

NOTARY PUBLIC

My commission expires:

4/6/2019

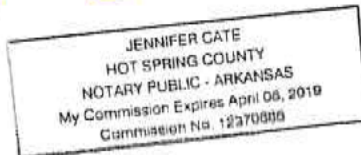

Individual Voting History Report

Mooney, Donna Mae

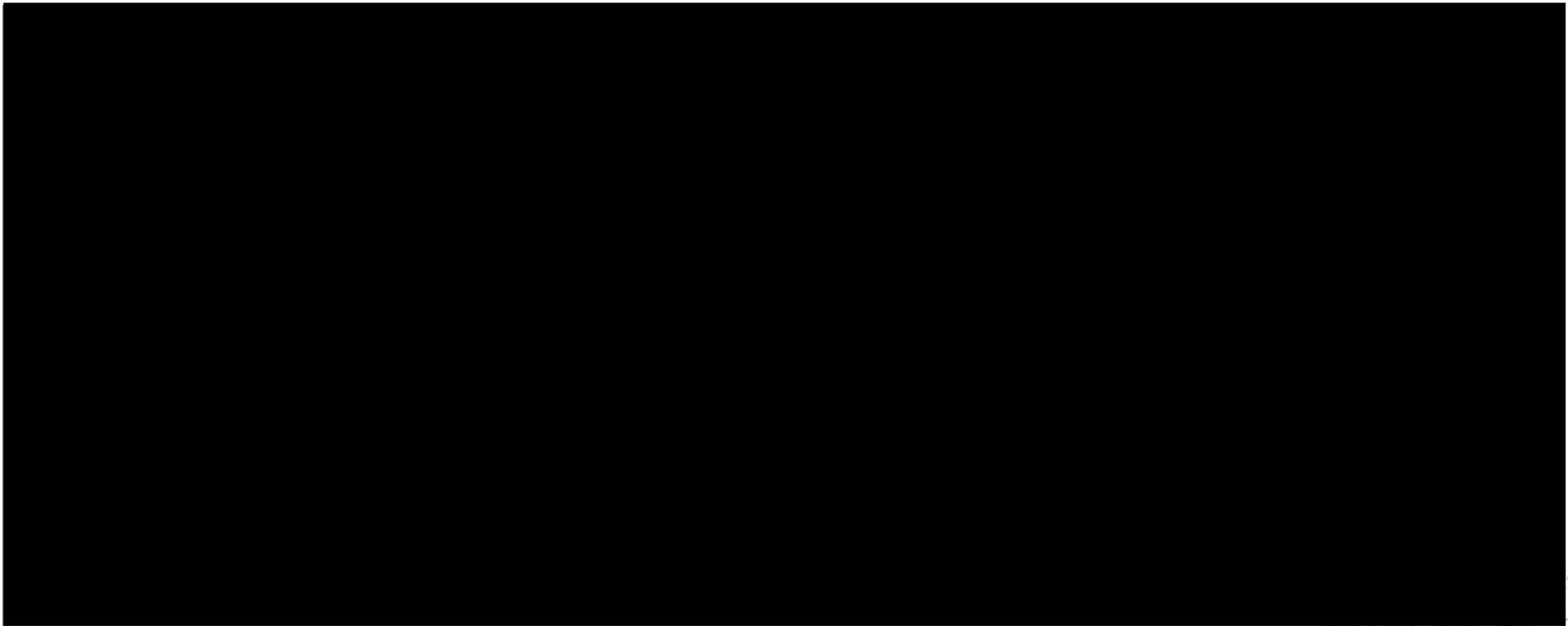

Certified This 2th Day of September 2017
By Rebecca D. Lynn
Deputy Clerk



Rebryl Clark

Confined Therapist Day of 50



Section B, Appendix 3

2007052506
07/06/2007 09:56:17 AM
Filed & Recorded in
Official Records of
PAT O'BRIEN
PULASKI COUNTY
CIRCUIT/COUNTY CLERK
Fees \$14.00

00030721

This Instrument Was Prepared By:
MITCHELL, WILLIAMS, SELIG,
GATES & WOODYARD, P.L.L.C.
425 West Capitol Avenue, Suite 1800
Little Rock, Arkansas 72201-3525

WARRANTY DEED

KNOW ALL PERSONS BY THESE PRESENTS:

THAT WE, **Donald K. Mooney and Donna M. Mooney, GRANTORS**, for and in consideration of the sum of Ten and No/100 dollars (\$10.00) and other valuable consideration, in hand paid by Donald Keith Mooney and Donna Mae Mooney, Trustee of the Mooney Family Revocable Living Trust, created the 2nd day of January, 2002, GRANTEES, the receipt of which is hereby acknowledged, do hereby grant, bargain, sell and convey unto the said Grantees, and unto their successors and assigns forever, the following lands lying in Pulaski County, Arkansas:

SEE EXHIBIT "A" ATTACHED HERETO FOR LEGAL DESCRIPTIONS

Subject to all liens and encumbrances of record.

TO HAVE AND TO HOLD the same unto the said Grantees and unto their successors and assigns forever with all appurtenances thereunto belonging.

And we hereby covenant with the said Grantees that we will forever warrant and defend the title to the said lands against all lawful claims whatever.

And we, for and in consideration of the said sum of money, do hereby release and relinquish unto the said Grantees, and unto their successors and assigns, all of our right and possibility of dower, curtesy and homestead in and to the said lands.

WITNESS our hands on this 5th day of July, 2007.

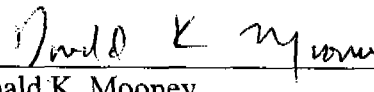

Donald K. Mooney

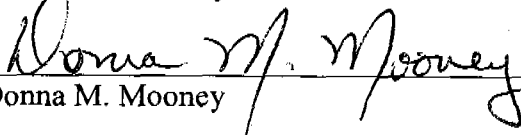

Donna M. Mooney



Section B, Appendix 3

STATE OF ARKANSAS)
)ss.
COUNTY OF PULASKI)

ACKNOWLEDGMENT

00001722

On this day, before me, the undersigned, a Notary Public, duly commissioned and acting, came Donald K. Mooney and Donna M. Mooney, to me well known as the Grantors in the foregoing deed, and stated that they had executed the same for the consideration, uses and purposes therein mentioned and set forth.

And Grantors declared that they had, of their own free wills, executed said instrument and signed and sealed the relinquishment of dower, curtesy and homestead therein for the consideration and purposes therein contained and set forth, without compulsion or undue influence of the other.

WITNESS my hand and official seal this 5th day of July, 2007.

Tracy Bruce

Notary Public

My Commission Expires:

5-1-11

(SEAL)



952826.1

The undersigned hereby certifies under penalty of false swearing that the legally correct amount of documentary stamps has been placed on this instrument. Exempt or no consideration paid if none shown.

[Signature]

[GRANTEE or GRANTEE's Agent]

GRANTEE's Address:



Section B, Appendix 3

Doc# 2007052506

EXHIBIT "A"

00000728

TRACT 1:



TRACT 2:

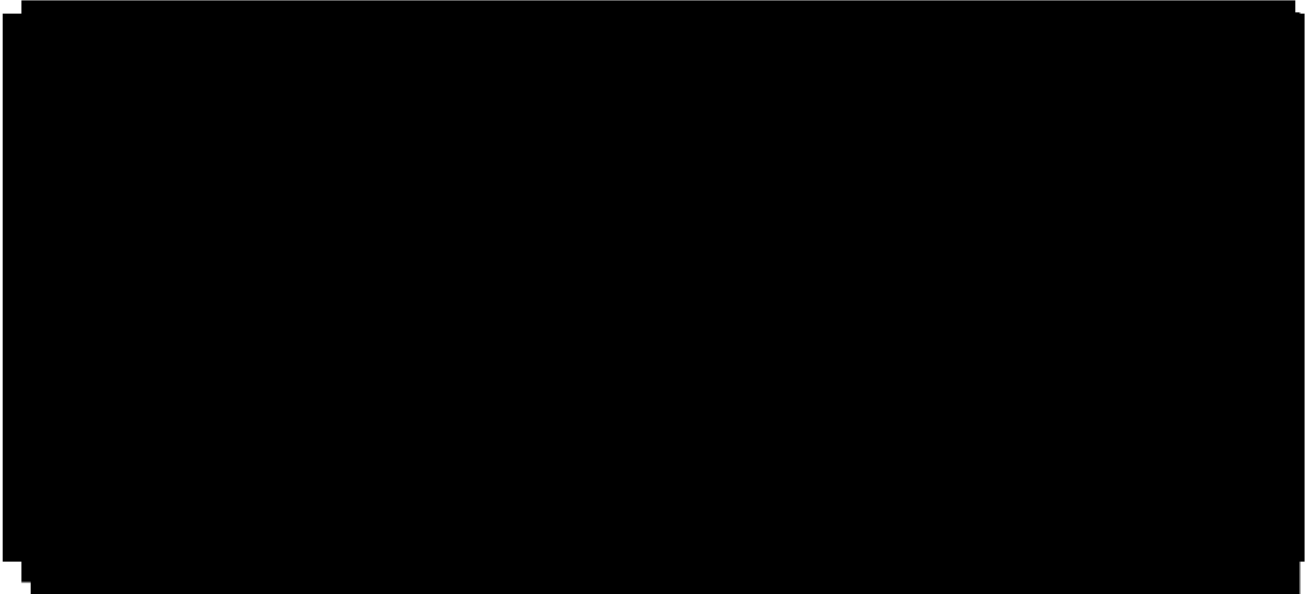

State of Arkansas }
 } *Scilicet:*
County of Pulaski }

Sworn Affidavit of
Dr. Donna Mooney Ph D

Dr. Donna Mooney Ph.D being first duly sworn and put upon oath to tell the truth, deposeseth and sayeth as follow:

1. My name is Dr. Donna Mooney, Ph.D and I am a trustee and beneficiary for the Mooney Family Revocable Living Trust an individual over the age of eighteen (18) years, competent to make this affidavit. I make this affidavit based upon my personal knowledge of the facts contained herein.
2. The Mooney Family Revocable Living Trust owns property located at [REDACTED] (the "Property").
3. I am personally familiar with Dr. Donald Keith Mooney M.D. who was a tenant at the Property from 1985 until present. To the best of my knowledge, he/she used the Property as his/her primary residence during that time.

AND FURTHER AFFIANT SAYETH NOT.

SIGNATURE:



Dr. Donna Mooney Affiant

VERIFICATION

Before me personally appeared the affiant, Dr. Donna Mooney to me well known or successfully proven to be the person stated above, who indicated that he/she has executed the foregoing affidavit under oath and for the purposes stated herein, this 14th day of September, 2017.

IN WITNESS WHEREOF, I have hereunder set my hand and official seal as a notary public in and for the State of Arkansas.



NOTARY PUBLIC

JENNIFER CATE
HOT SPRING COUNTY
NOTARY PUBLIC - ARKANSAS
My Commission Expires April 06, 2019
Commission No. 12370688

My commission expires:
4/6/19

ARKANSAS STATE POLICE
Arkansas Criminal History Report

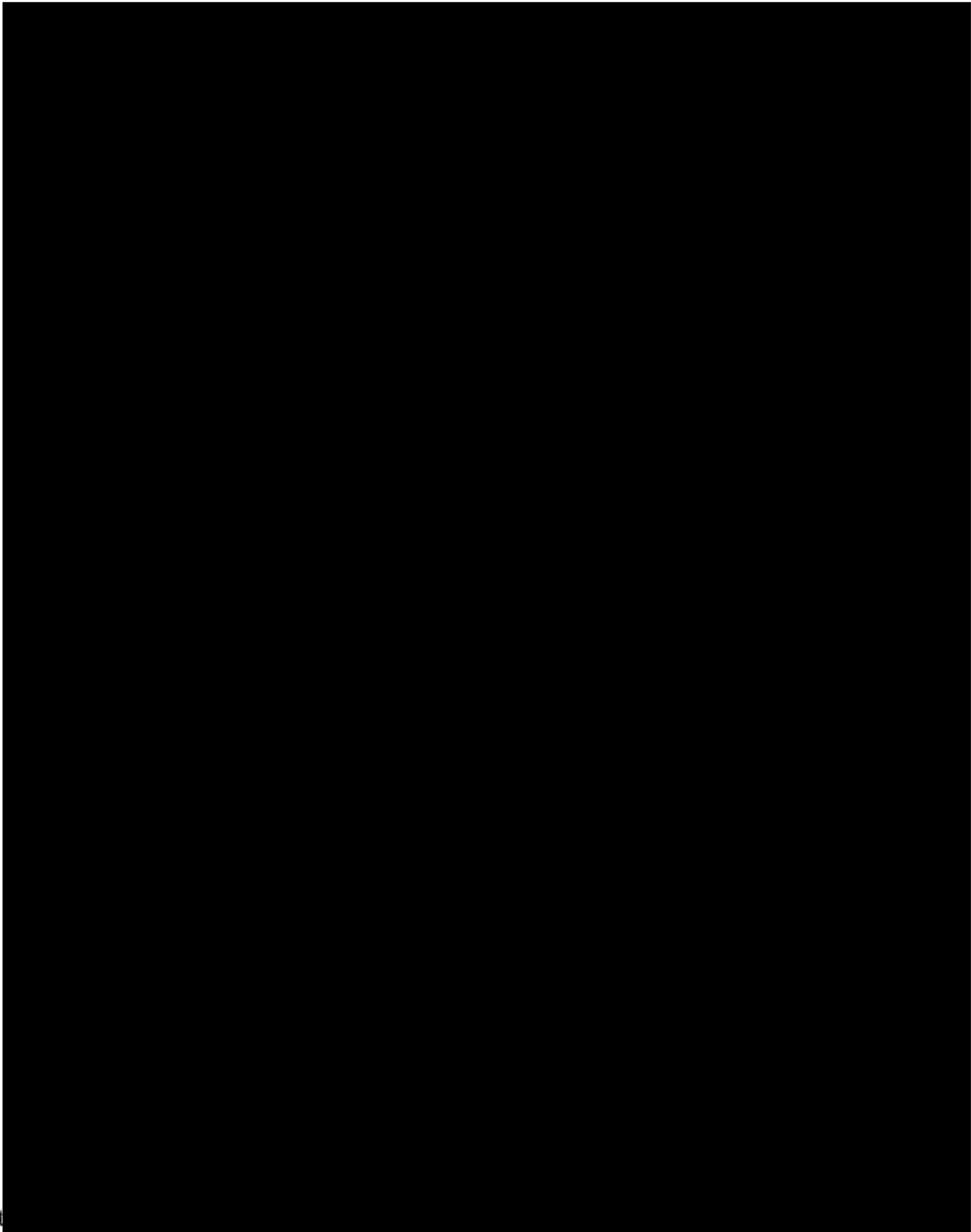

APPLICATION FOR MEDICAL MARIJUANA CULTIVATION FACILITY

SECTION B. Applicant, Owner, Officer, or Board Member Disclosure Statement

Identify your affiliation with the proposed cultivation facility (Applicant, Owner, Officer, Board Member?) Include your percentage of equity ownership in the facility, if any.

Affiliation: Applicant, Owner, President & CEO, Chairman of the Board

Percentage of Equity Ownership: 15.72%

Legal Name

*In addition to the information below, you are required to provide supporting documents to prove your legal name. See Section B, Appendix 1 for acceptable forms of proof.

Last Name Courtright

First Name Joseph

Middle Name Charles

Maiden Name (if applicable) _____

Alias(es) or former names _____

SSN [REDACTED]

Date of Birth

*In addition to providing your date of birth, you are required to provide supporting documents to prove your date of birth. See Section B, Appendix 2 for acceptable forms of proof.

Date of Birth [REDACTED]

Contact Information

Mailing Address [REDACTED]

Phone Number (primary contact number) [REDACTED]

Email Address joe.courtright@gmail.com

Residency

Are you an Arkansas resident? Yes

If you are not an Arkansas resident, please identify your primary place of residence.

Have you been an Arkansas resident for the past seven (7) years? Yes

If you answered “yes” to the question above, in addition to providing the information requested below, you are required to provide supporting documents to prove your residency for the past seven (7) years. See Section B, Appendix 3 for acceptable forms of proof.

Provide the address of your primary residence(s) for the past seven (7) years. Identify the dates (month and year) you resided at each listed location:

10-18-2010 to Present

9-22-2006 to 10-18-2010

Tax Liability

Do you have any outstanding tax delinquencies owed to the State of Arkansas: No

If you answered “yes” to the previous question, please explain the nature of any delinquencies:

Other Financial Liabilities

Are you a party to any legal proceedings where damages, fines, or civil penalties may reasonably be expected to exceed \$500,000 above any insurance coverage available to cover the claim?

No

If the answer to the above question is “yes”, attach a statement describing the litigation, including the title and docket number of the litigation, the name and location of the court in which it is pending, the identity of all parties to the litigation, the general nature of the claims being made and the impact an unfavorable opinion may have on your ability to finance and operate the proposed cultivation facility. Any documents submitted in response to this requirement must be labeled with “Section B, Other Financial Liabilities”.

Regulatory History

Have you, or has any entity over which you exercised management or control, ever had any fines or other penalties over \$10,000 assessed by any regulatory agency? **No**

If the answer above is “yes”, attach a statement providing the details of such fines or penalties. Any documents submitted in response to this requirement must be labeled with “Section B, Regulatory History”.

Professional Licensure

Do you presently hold any type of professional license? **Yes**

If yes, identify the type of license and license number Arkansas Pharmacist Lic# PD14093, Kansas # 1-11430, OK # 11033, MO # 042724

Is the license in good standing? **Yes**

Certification

I, Joseph Courtright, certify that the information provided in this form and its attachments is complete and accurate. I understand that any misstatement or concealment of fact may be grounds for refusal of application or revocation of license if later disclosed.

Signed this 28th day of July, 2017.

Signature of Applicant, Owner, Officer, or Board Member

Subscribed and sworn to before me this 28th day of July, 2017.

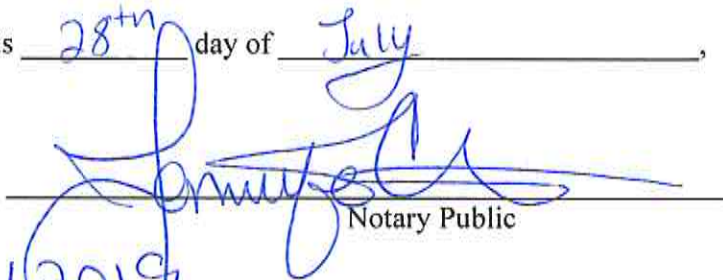

Notary Public

My Commission Expires: 4/6/2019

JENNIFER CATE
HOT SPRING COUNTY
NOTARY PUBLIC - ARKANSAS
My Commission Expires April 06, 2019
Commission No. 12370686

Section B, Appendix 2

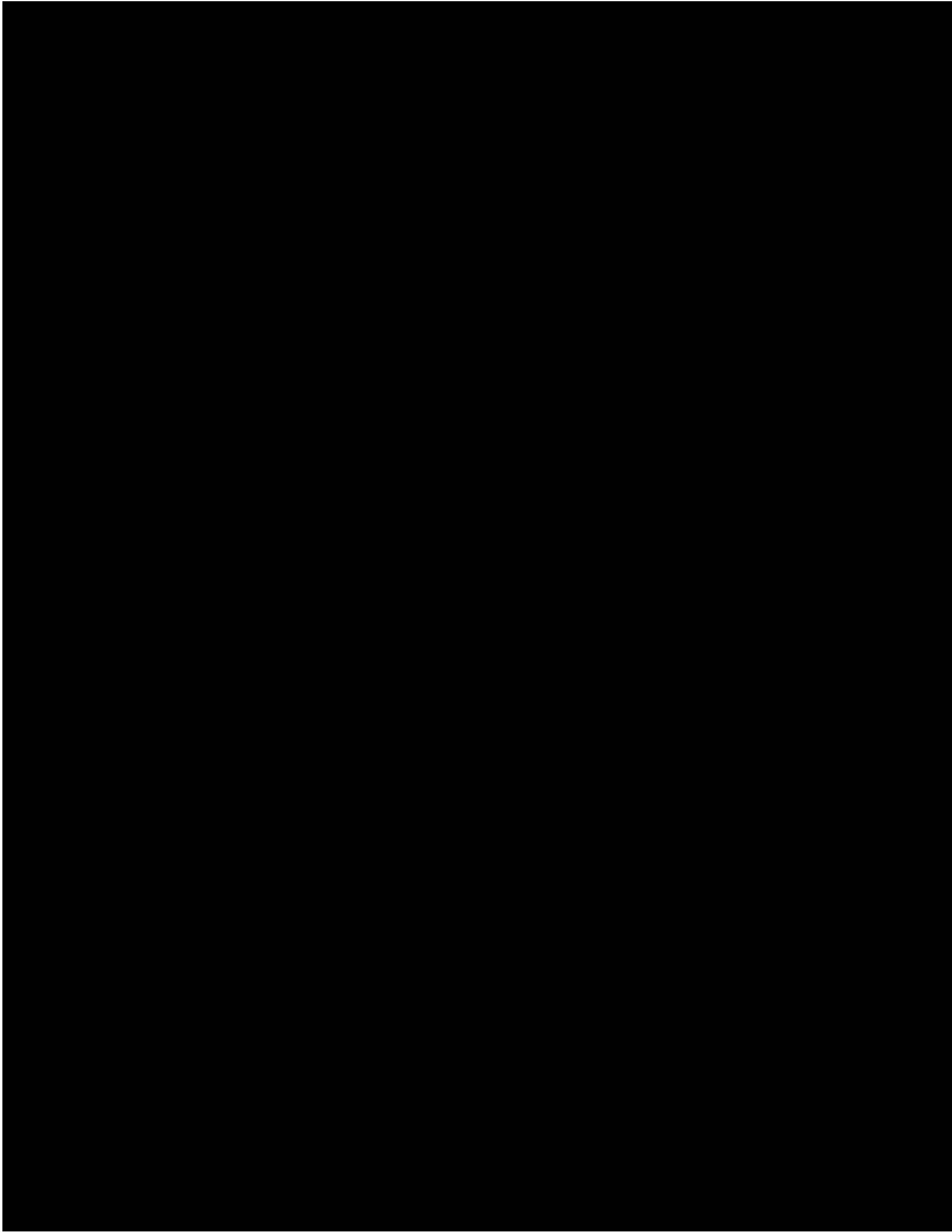



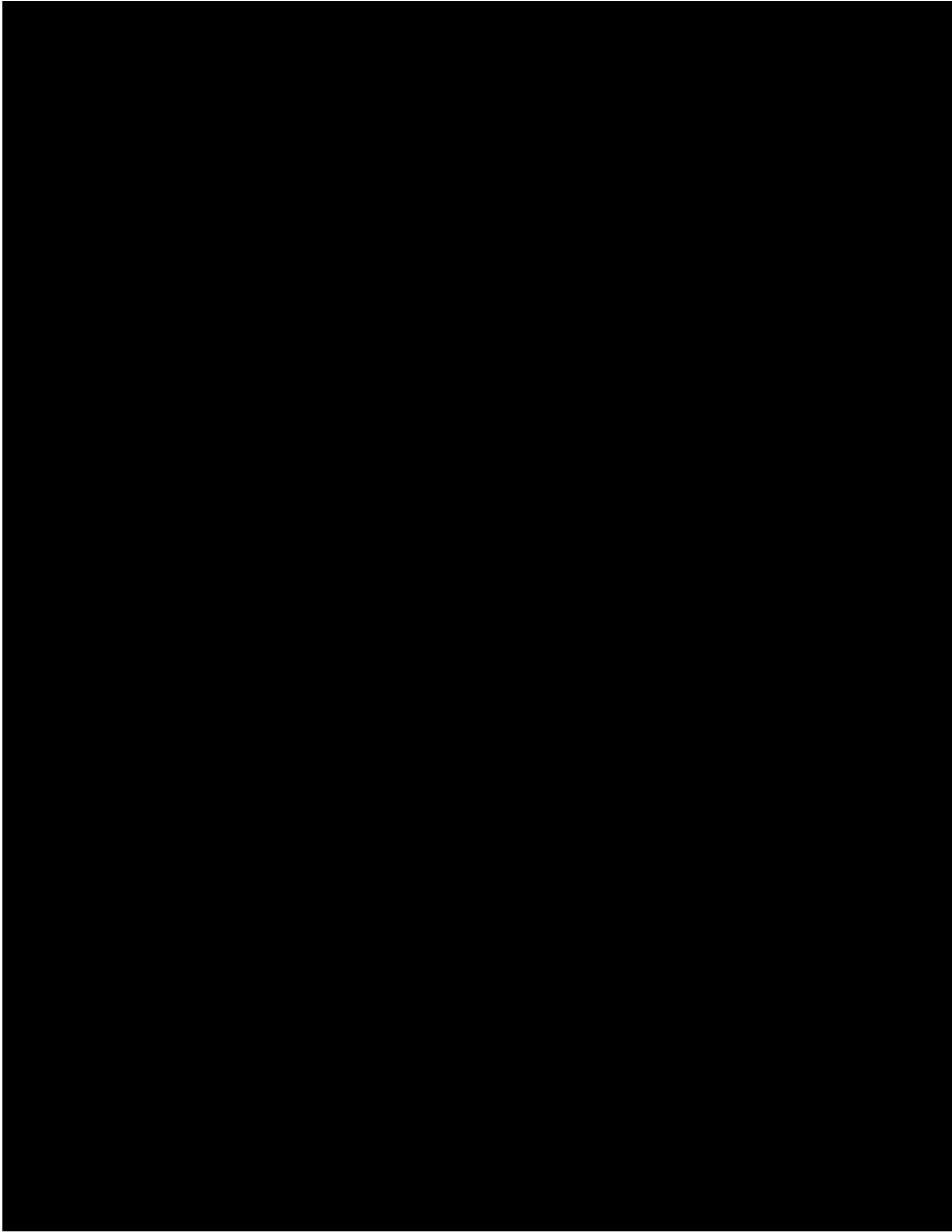

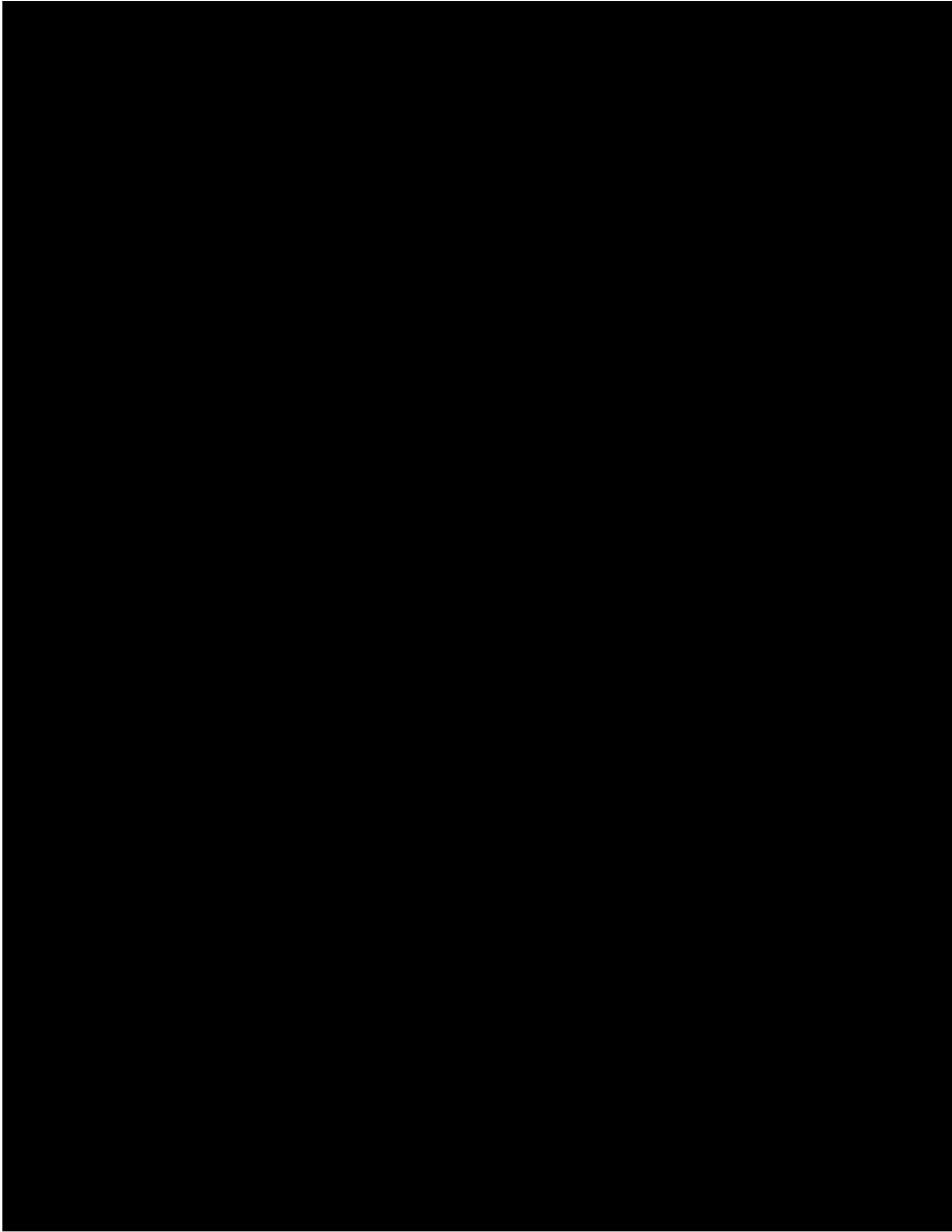

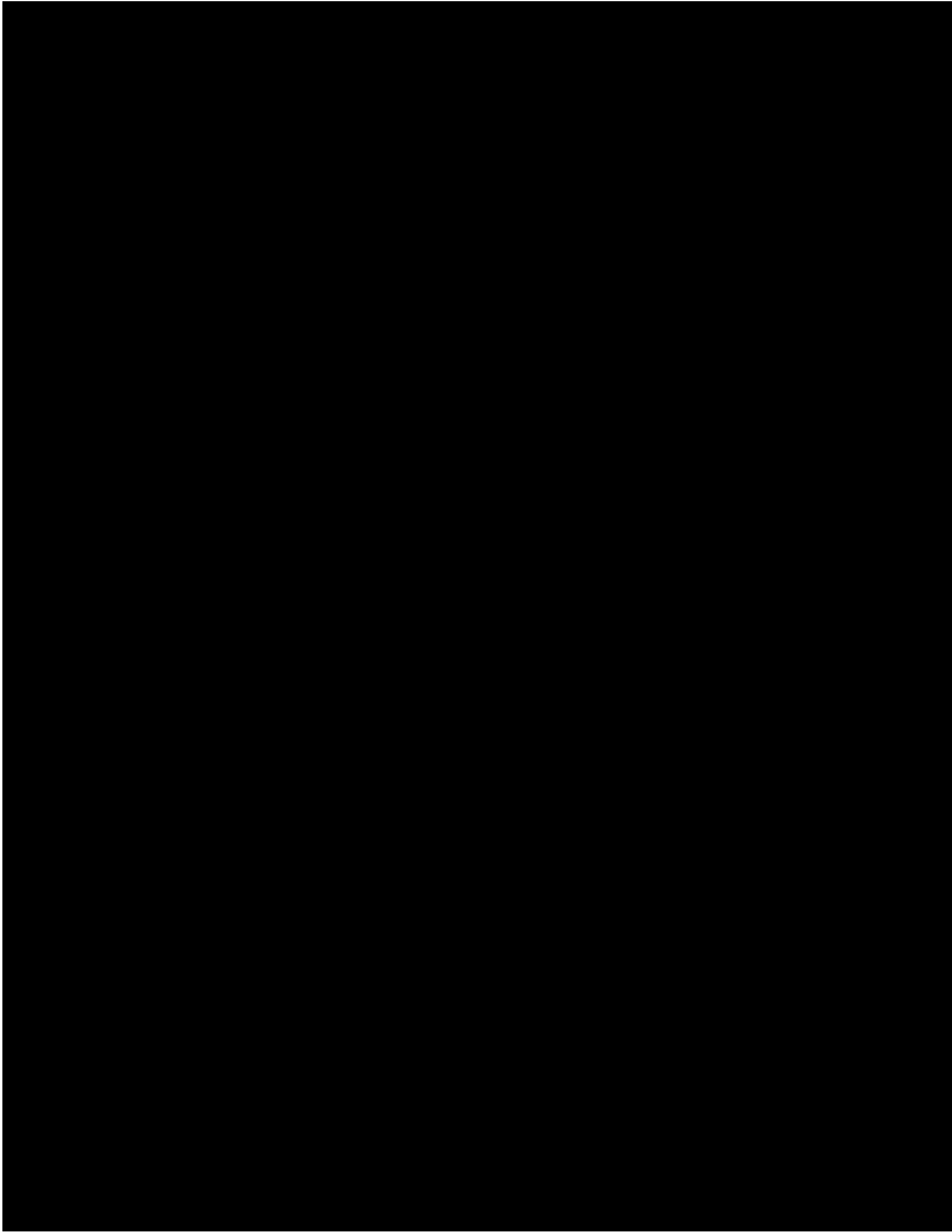

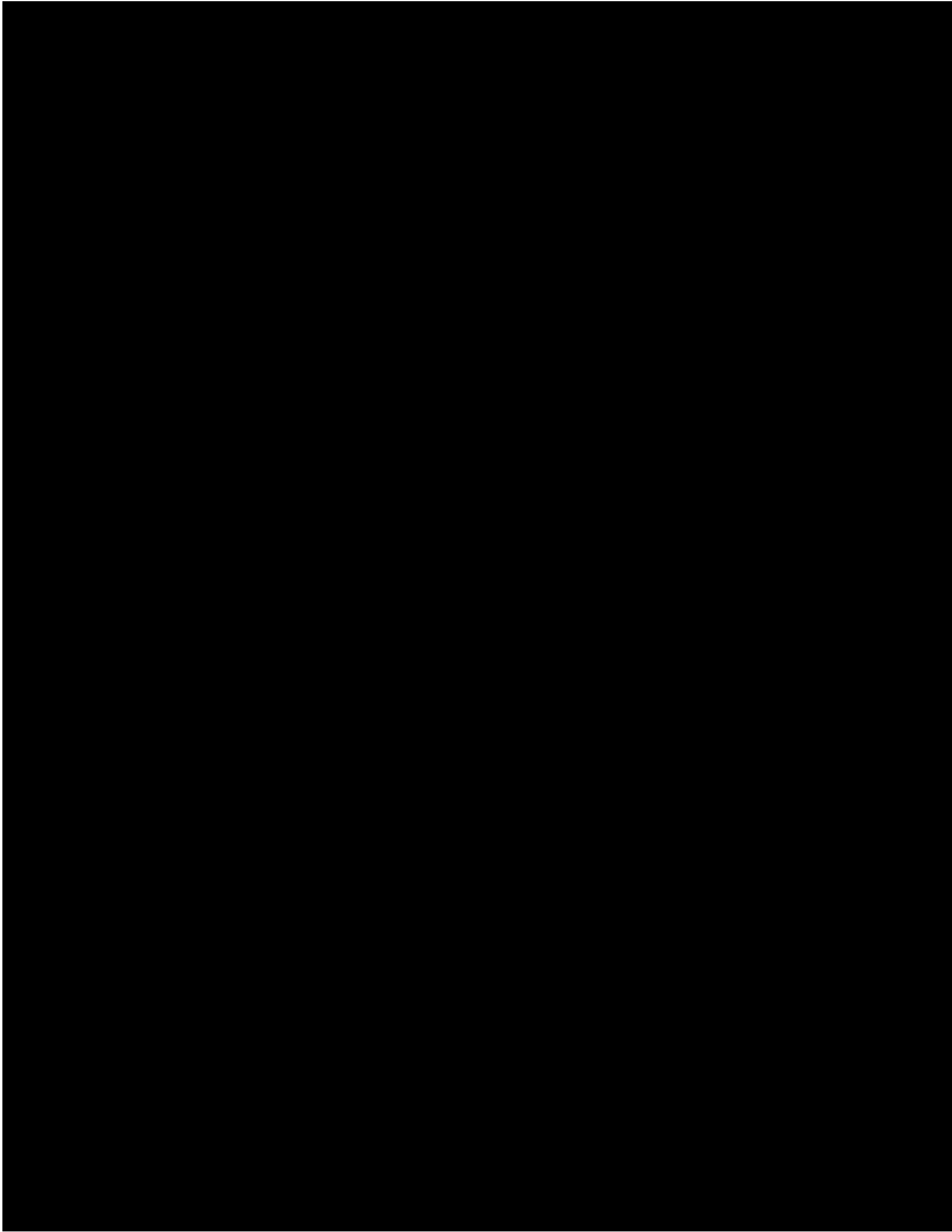

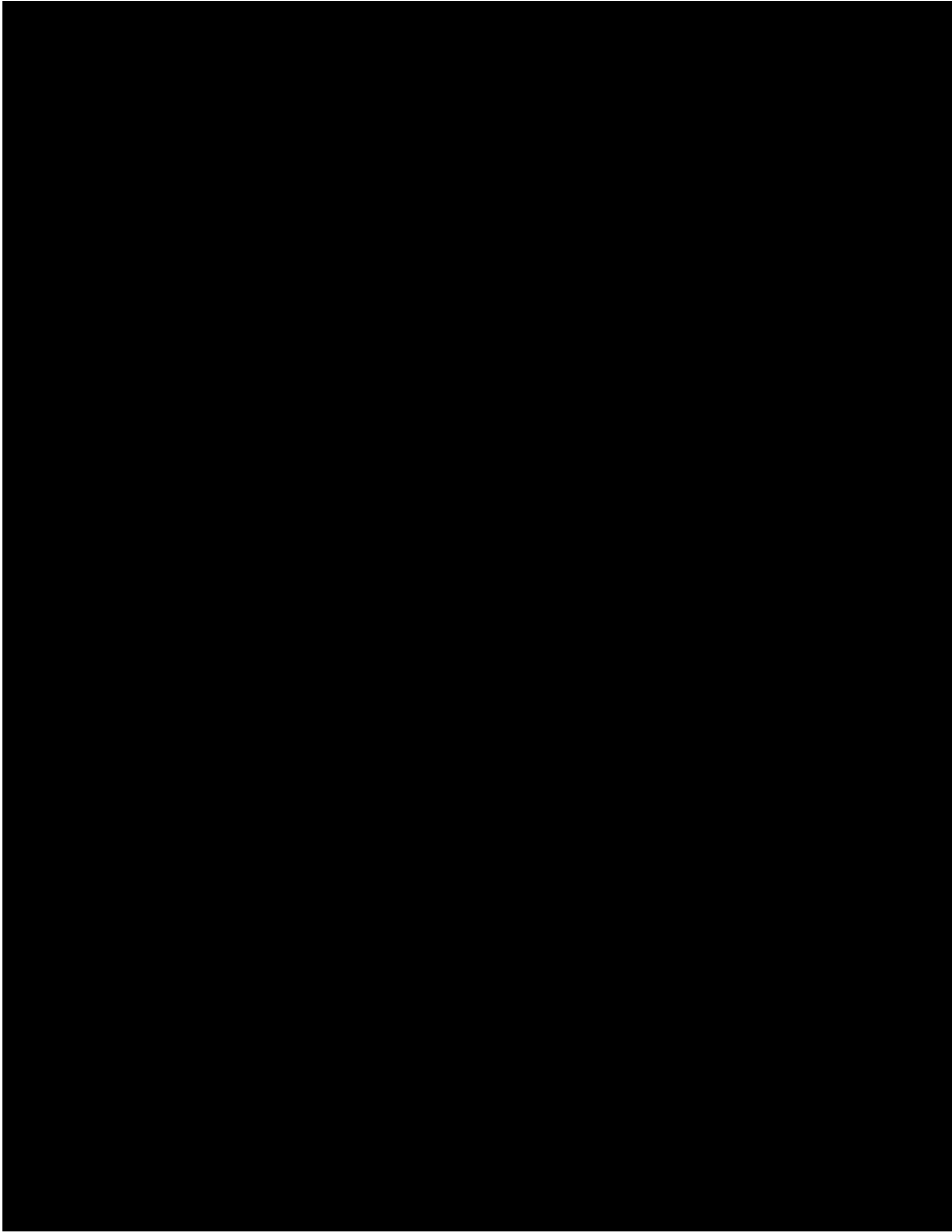

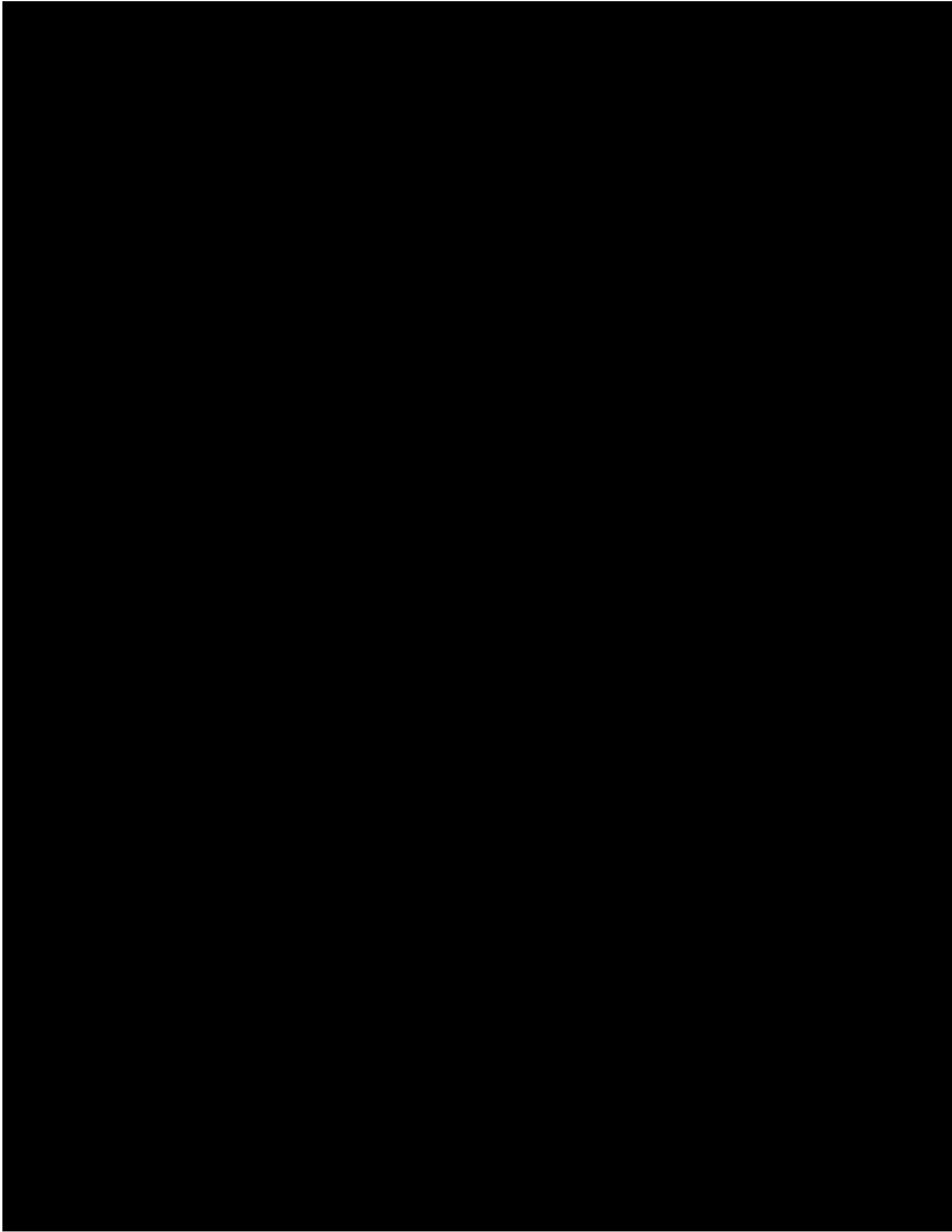

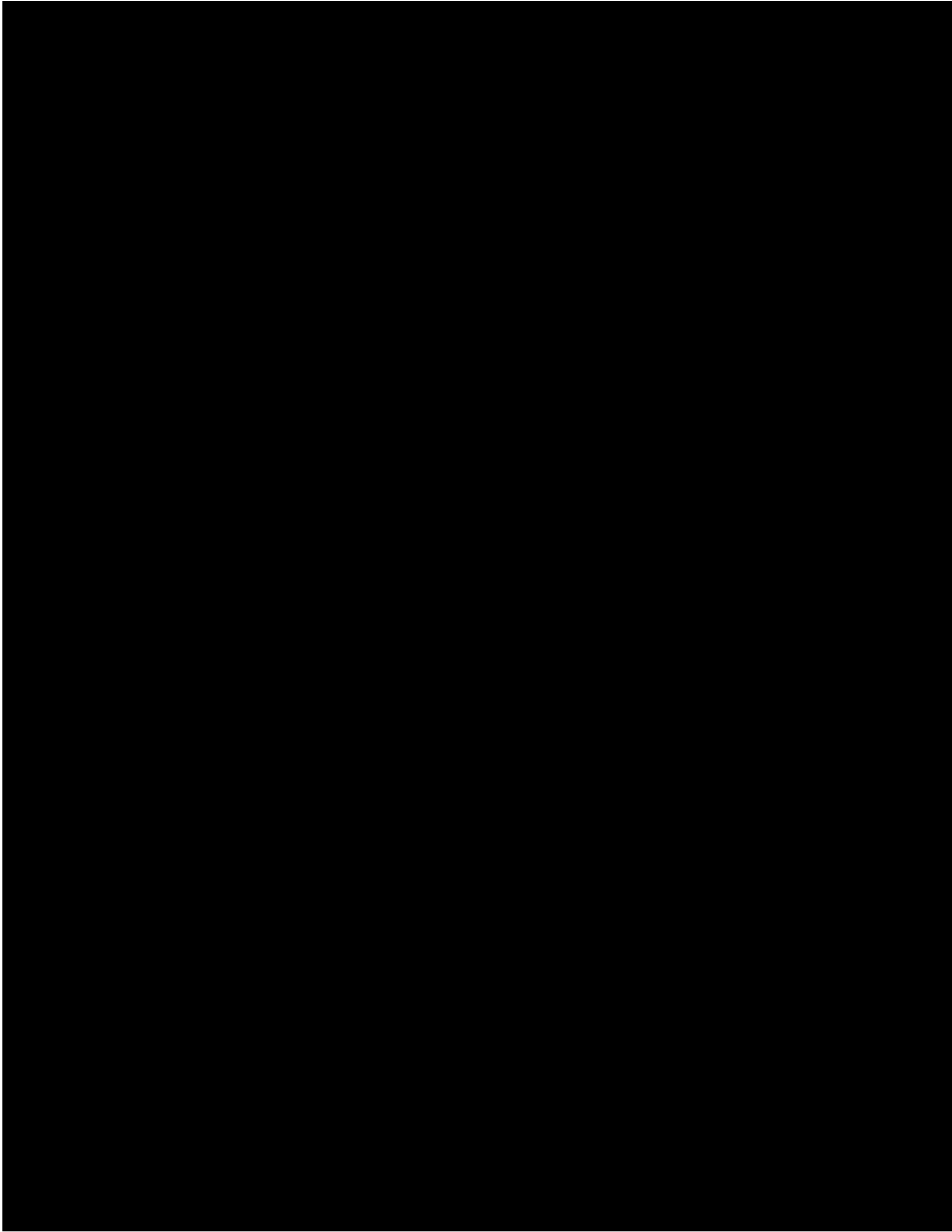

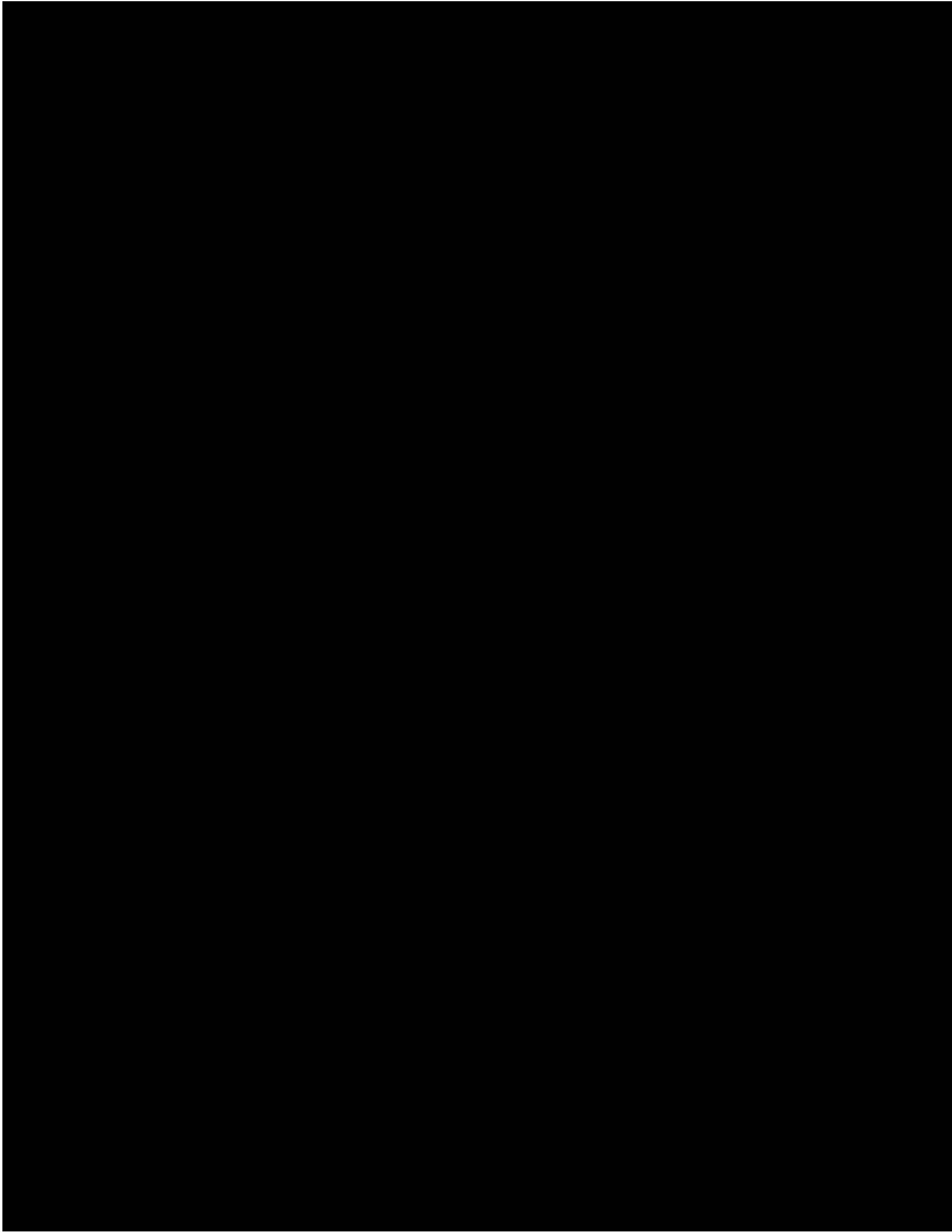

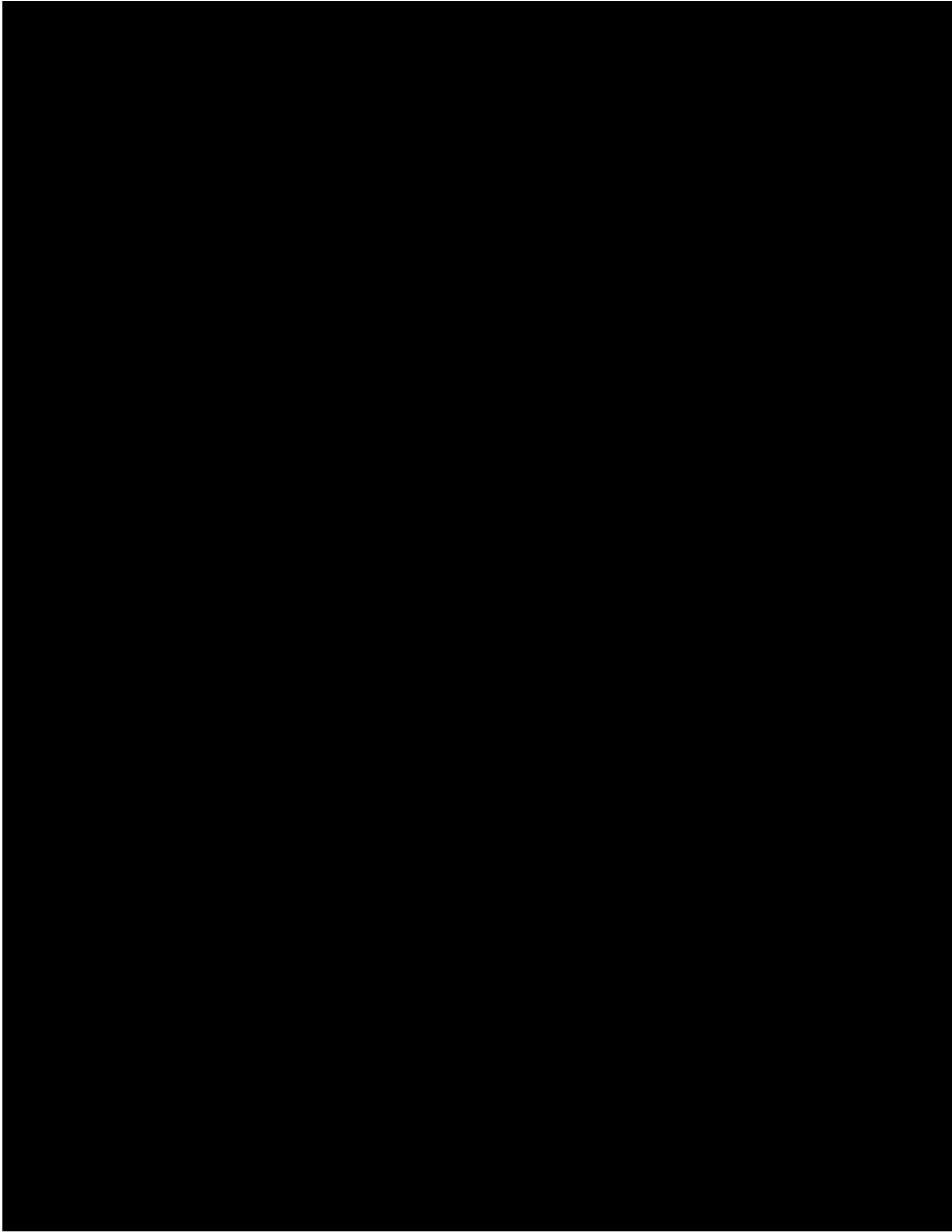

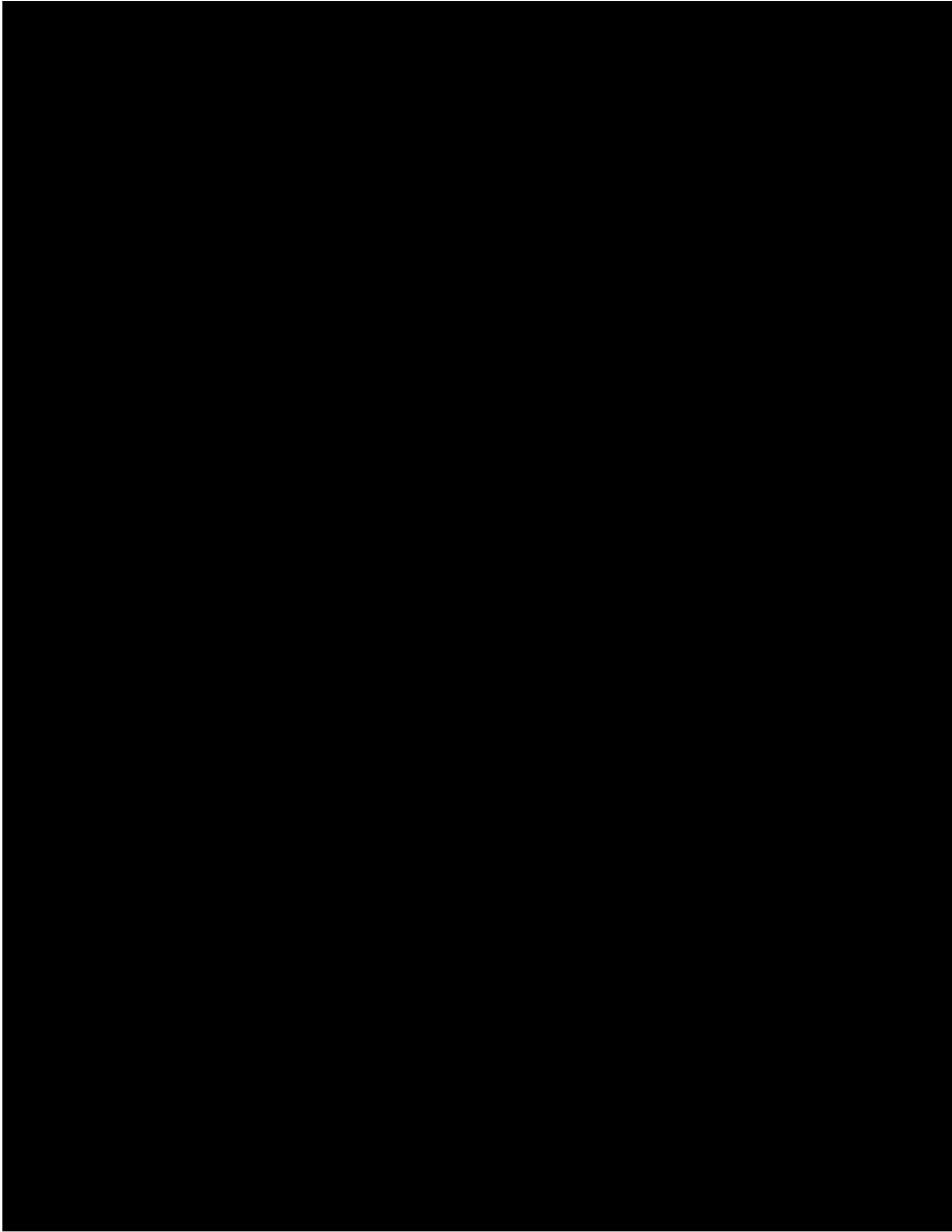

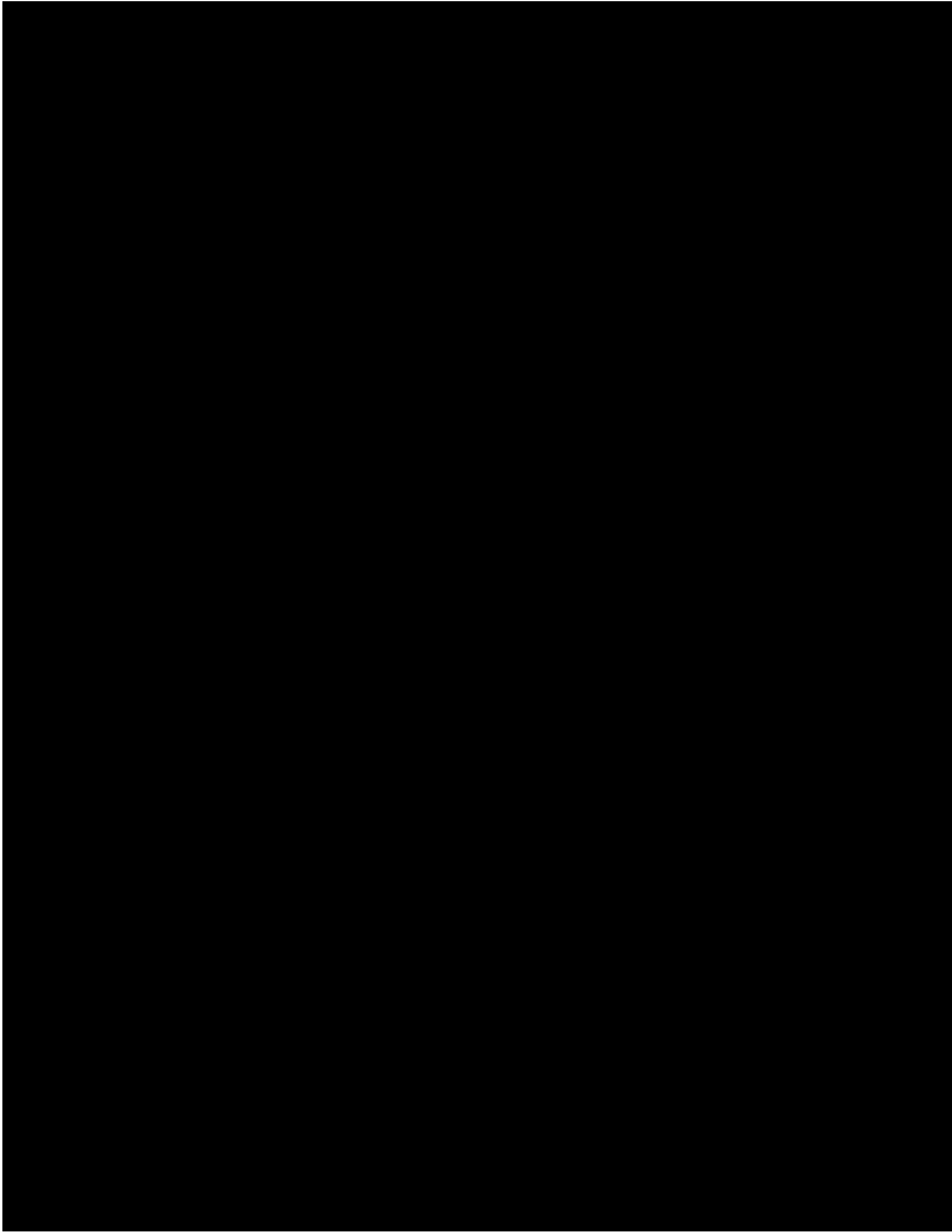

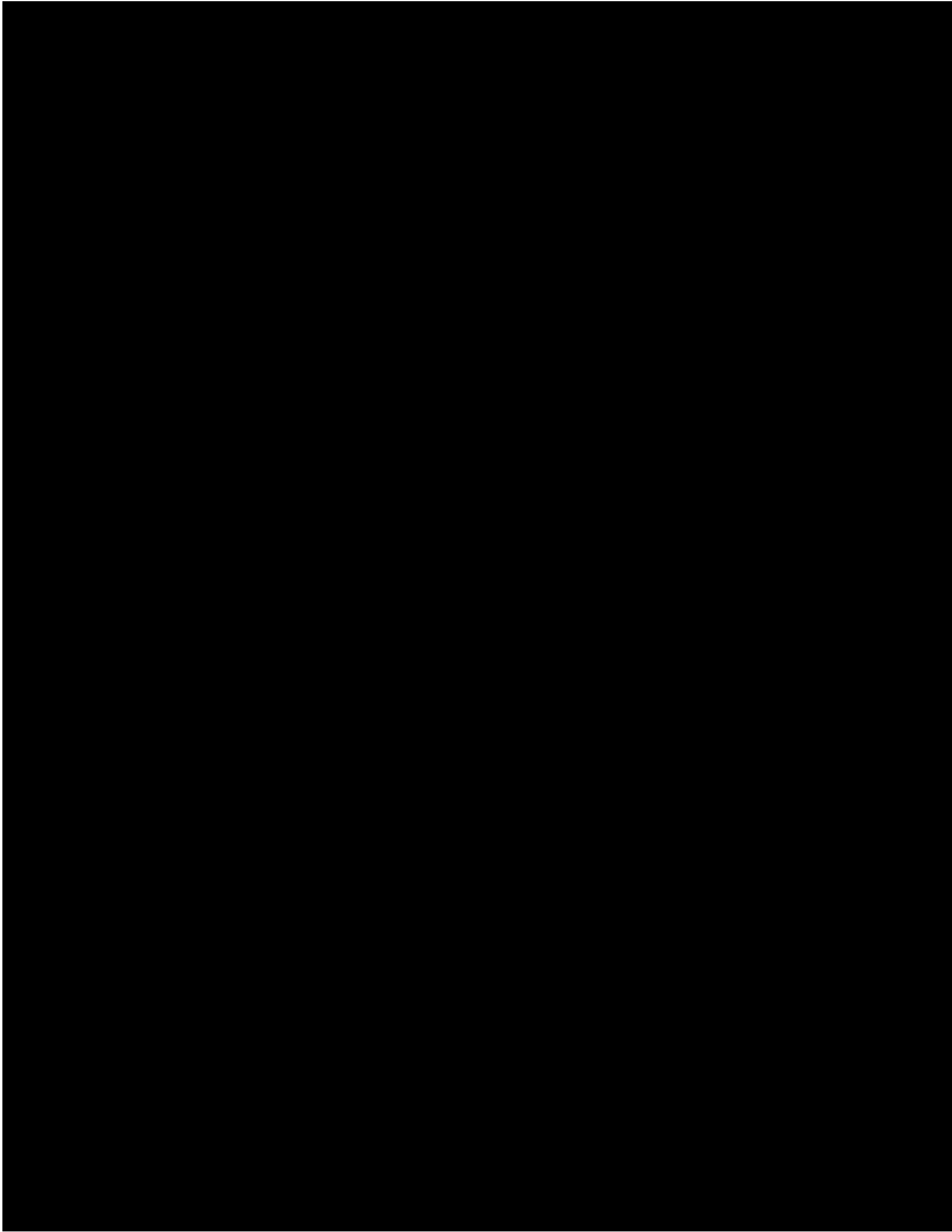

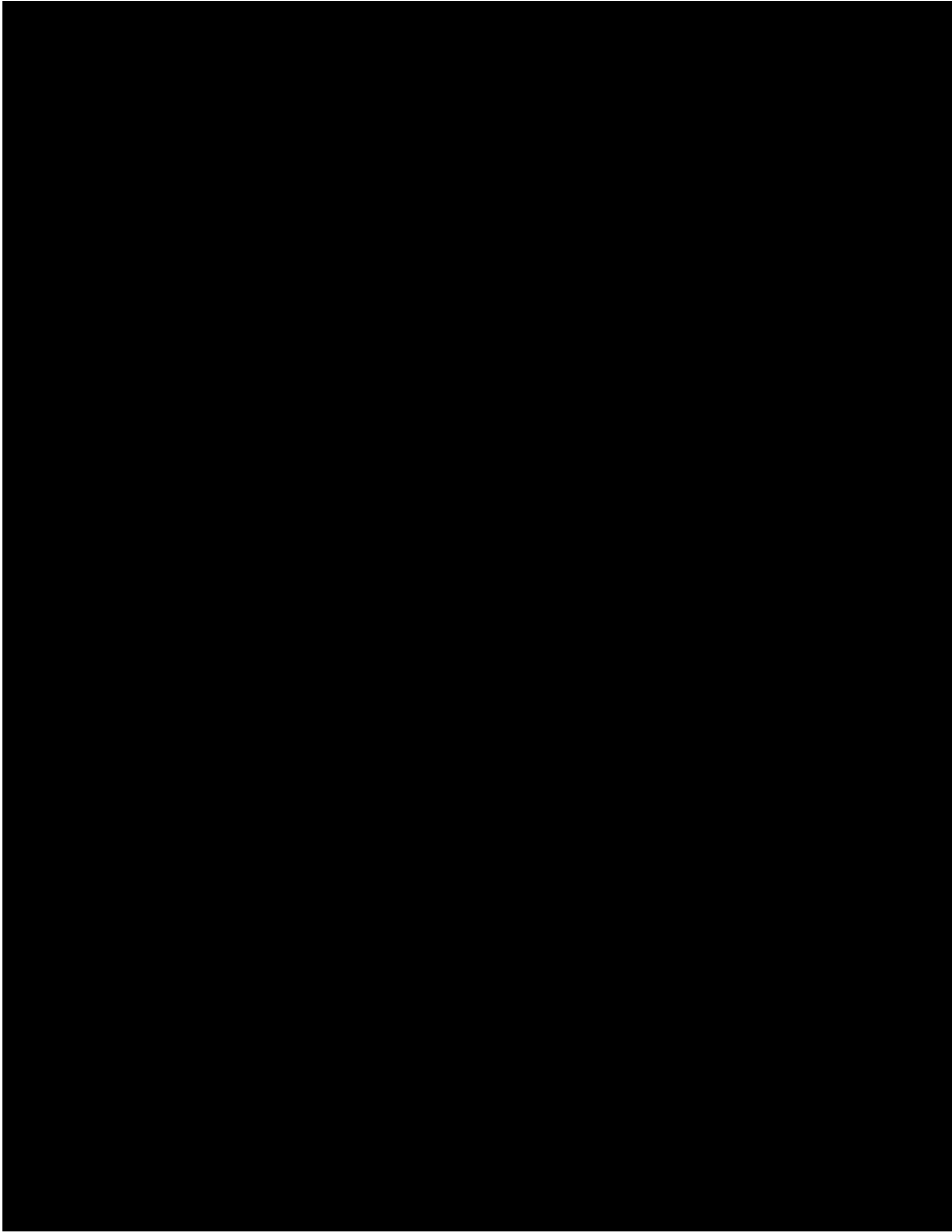

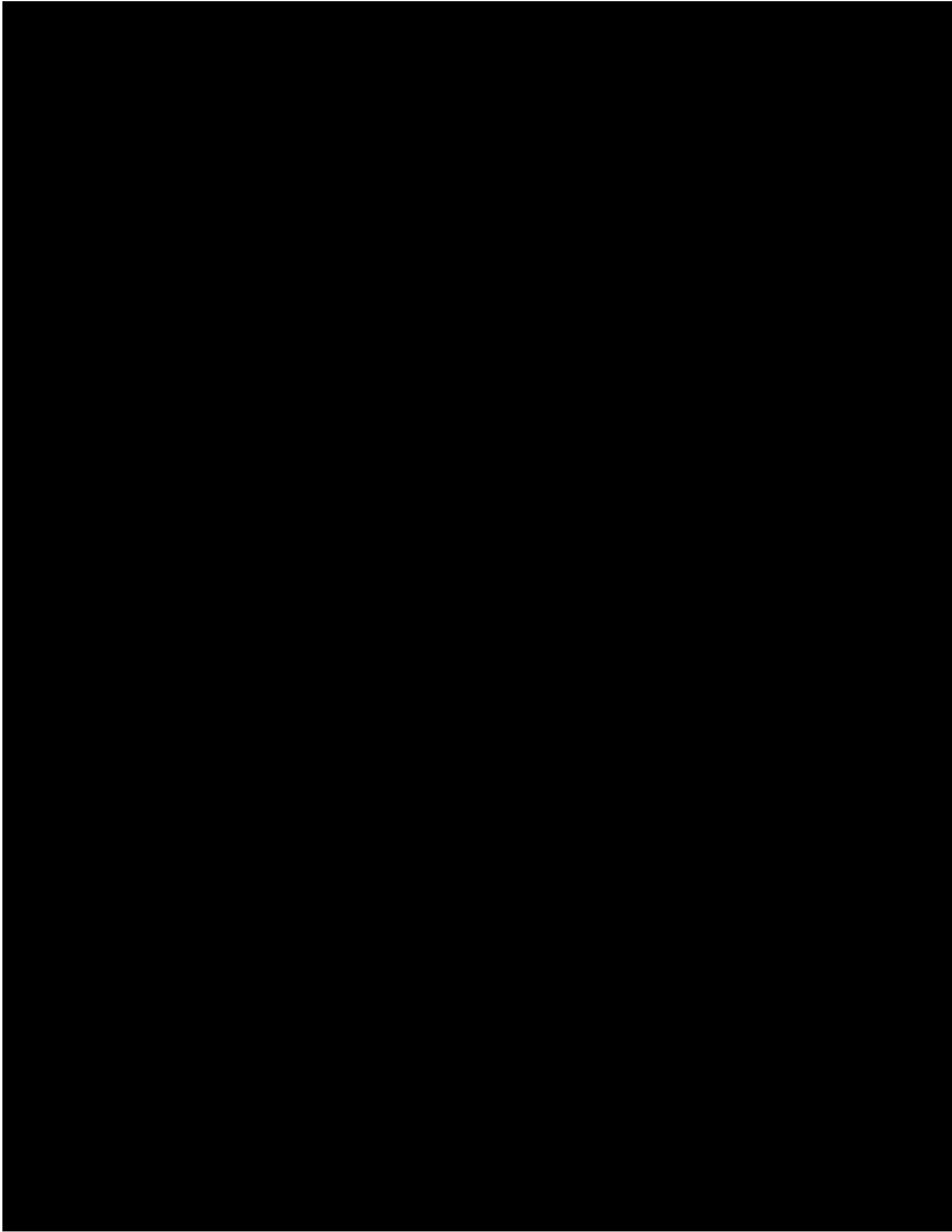

Section B, Appendix 3

Created: 7/28/2017 2:12:16 PM

Parcel History Report

Basic Information	
Parcel Number:	33L0300004600
County Name:	Pulaski County
Owners Name:	COURTRIGHT JOSEPH C
Billing Name:	COURTRIGHT JOSEPH C
Billing Address:	[REDACTED]
City, State, Zip:	[REDACTED]

Assessment History

Year	Assessed Land	Assessed Building	Total Assessed	Taxable Value
2017	106,670	191,990	298,660	284,170
2013	96,000	174,640	270,640	270,640
2012	96,000	174,640	270,640	270,640
2012	84,000	178,850	262,850	262,850
2012	84,000	171,180	255,180	255,180
2011	60,000	237,293	297,293	297,293
2010	60,000	237,293	297,293	225,581
2009	60,000	237,293	297,293	214,841
2008	43,800	160,810	204,610	204,610
2007	43,800	160,810	204,610	204,610
2006	60,000	229,203	289,203	289,203
2005	21,375	80,409	101,784	101,784
2004	43,800	160,810	204,610	101,784
2003	43,800	57,984	101,784	101,784
2002	35,524	0	35,524	35,524

Ownership History

Date	Price	Grantor	Grantee	Book	Page	Deed Type
10/18/2010	1,275,000	JAQUISS ROBERT / CHERYL L	COURTRIGHT JOSEPH C	2010	065638	WD (Warranty Deed)
12/30/2005	1,200,000	MOORE WAYNE CONSTR CO	JAQUISS ROBERT D B/CHERYL L	2006	000965	WADS ()
3/22/2005	1,060,000	GOFF to MOORE		05	024068	WADS ()
9/21/2004	0	GOFF TR TO GOFF & ASSOC		04	078979	TRD (Treasurer's Deed)
12/5/2003	0	GOFF ROBT to GOFF MARIAN RESID		03	123092	WADS ()
1/1/1998	22			98	5544	DEED (Deed)
12/1/1985	320,000			85	69397	DEED (Deed)

Section B- Appendix 3

State of Arkansas }
 } *Scilicet:*
County of Pulaski }

Sworn Affidavit of
Jimmy Moses

Jimmy Moses being first duly sworn and put upon oath to tell the truth, depose and sayeth as follow:

1. My name is Jimmy Moses, and I am an individual over the age of eighteen (18) years, competent to make this affidavit. I make this affidavit based upon my personal knowledge of the facts contained herein.
2. I managed property located at [REDACTED] the "Property").
3. I am personally familiar with Joseph Courtright, who was a tenant at the Property from 9-22-2006 until 10-20-2010. To the best of my knowledge, he/she used the Property as his/her primary residence during that time.

AND FURTHER AFFIANT SAYETH NOT.

SIGNATURE:

Jimmy Moses, Affiant

VERIFICATION

Before me personally appeared the affiant, Jimmy Moses, to me well known or successfully proven to be the person stated above, who indicated that he/she has executed the foregoing affidavit under oath and for the purposes stated herein, this 15th day of August, 2017.

IN WITNESS WHEREOF, I have hereunder set my hand and official seal as a notary public in and for the State of Arkansas.

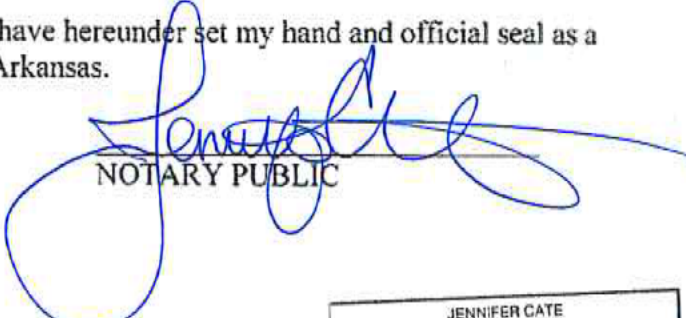
NOTARY PUBLIC

My commission expires:

4/6/2019

JENNIFER CATE
HOT SPRING COUNTY
NOTARY PUBLIC - ARKANSAS
My Commission Expires April 06, 2019
Commission No. 12370686

Individual Voting History Report

Courtright, Joseph

[REDACTED]

[REDACTED]

[REDACTED] his [REDACTED]
By [REDACTED]



[REDACTED]

By _____ Deputy Clerk

Continued from _____ Day of _____ 20____



Arkansas State Board of Pharmacy

322 South Main Street, Suite 600, Little Rock, Arkansas 72201 • 501-682-0190 • 501-682-0195 (fax) www.pharmacyboard.arkansas.gov

2017 - 2017 PHARMACIST LICENSE

Joseph Charles Courtright
39 Edgehill Road
Little Rock, AR 72207

Pharmacist License: PD14093, Original License Date: 07/01/2017

This is to certify that the Pharmacist named hereon is licensed under the provisions of the Arkansas Pharmacy Practice Act and Arkansas Pharmacy Regulations with the following licenses/endorsements:

License Type:
Pharmacist License

License #:
PD14093

Amount Paid:
\$0.00

All Licenses/Endorsements Expire: 12/31/2017

This permit is not transferable and must be prominently displayed.

Arkansas State Board of Pharmacy

The address above is the mailing address where all correspondence from the board will be sent, including renewal information. All changes to contact information can be made online at www.pharmacyboard.arkansas.gov under "License Maintenance."



Arkansas State Board of Pharmacy
322 South Main Street, Suite 600, Little Rock, AR 72201
501-682-0190 • Fax (501) 682-0195
www.pharmacyboard.arkansas.gov • asbp@arkansas.gov

Joseph Charles Courtright
Pharmacist License: PD14093
Original License Date: 07/01/2017

This card is for reference purposes only. Your license must be displayed in a conspicuous location in the pharmacy where you are working.

**Section B -
Professional Licensure**

Display this conspicuously
License Number: 1-11430

KANSAS STATE BOARD OF PHARMACY

800 S.W. Jackson, Ste. 1414
Topeka, KS 66612-1244
785-296-4056

Fax 785-296-8420

www.pharmacy.ks.gov
pharmacy@pharmacy.ks.gov

Expires: 6/30/2018

Joseph Courtright
Executive Director

**JOSEPH COURTRIGHT
39 EDGEHILL ROAD
LITTLE ROCK, AR 72207**

Pocket Card



This is to Certify that the following individual is hereby renewed as a Pharmacist

Section B - Professional Licensure



JOSEPH C COURTRIGHT
39 EDGEHILL ROAD
LITTLE ROCK AR 72207
USA

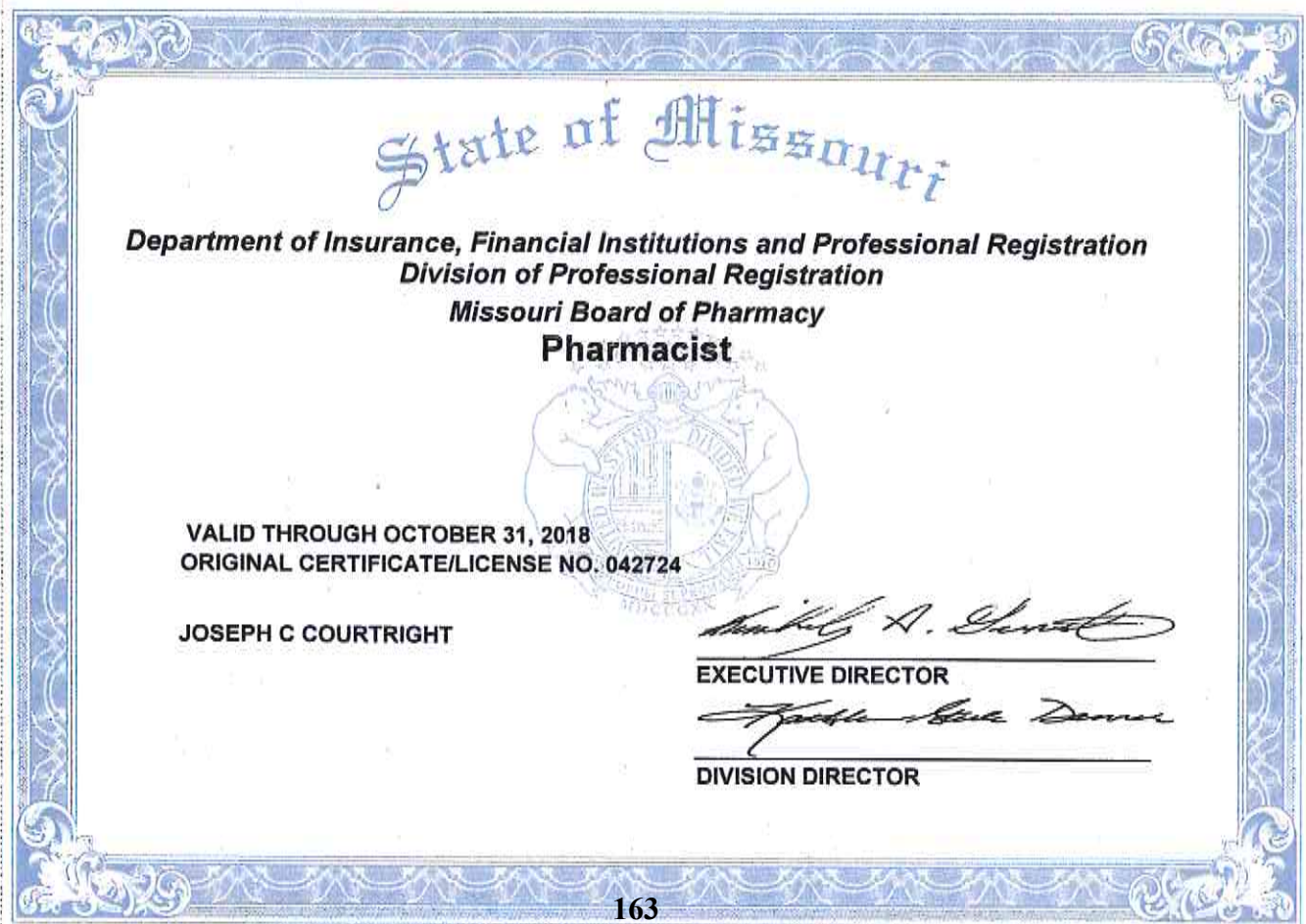

**Section B - Professional
Licensure**



Oklahoma State Board of Pharmacy
4545 Lincoln Blvd, Ste 112, Oklahoma City, OK 73105
405.521.3815

LICENSE RENEWAL RECEIPT

DATE: 12/01/2016
RECEIPT NO: 38448082
AMOUNT: \$100.00

JOSEPH CHARLES COURTRIGHT
39 EDGEHILL RD
LITTLE ROCK, AR 72207-5461

INSTRUCTIONS: Cut along dotted lines and post the completed permit in the pharmacy. A separate permit must be printed and signed for each pharmacy where you are employed.



Oklahoma State Board
Of Pharmacy
Doctor of Pharmacy

11033 - Active

COURTRIGHT JOSEPH CHARLES COURTRIGHT
EXPIRES JANUARY 31, 2018



Oklahoma State Board
Of Pharmacy
Doctor of Pharmacy

11033 - Active

JOSEPH CHARLES
EXPIRES JANUARY 31, 2018

ARKANSAS STATE POLICE

Arkansas Criminal History Report

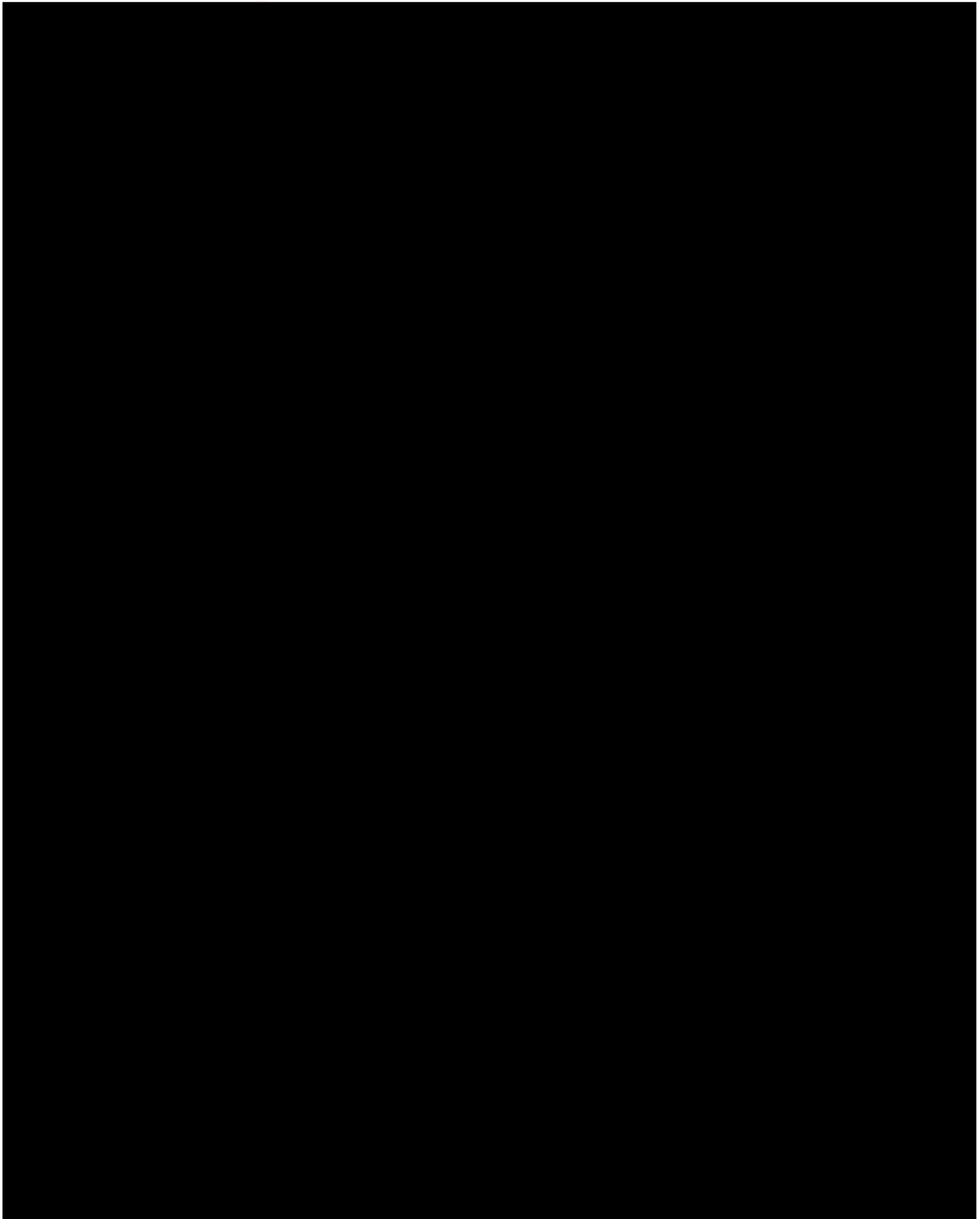

APPLICATION FOR MEDICAL MARIJUANA CULTIVATION FACILITY

SECTION B. Applicant, Owner, Officer, or Board Member Disclosure Statement

Identify your affiliation with the proposed cultivation facility (Applicant, Owner, Officer, Board Member?) Include your percentage of equity ownership in the facility, if any.

Affiliation: Owner

Percentage of Equity Ownership: 7.51%

Legal Name

*In addition to the information below, you are required to provide supporting documents to prove your legal name. See Section B, Appendix 1 for acceptable forms of proof.

Last Name Peck

First Name Kathryne

Middle Name Deane

Maiden Name (if applicable) Bradford

Alias(es) or former names _____

SSN [REDACTED]

Date of Birth

*In addition to providing your date of birth, you are required to provide supporting documents to prove your date of birth. See Section B, Appendix 2 for acceptable forms of proof.

Date of Birth [REDACTED]

Contact Information

Mailing Address [REDACTED]

Phone Number (primary contact number) [REDACTED]

Email Address offsightach@yahoo.com

Residency

Are you an Arkansas resident? Yes

If you are not an Arkansas resident, please identify your primary place of residence.

Have you been an Arkansas resident for the past seven (7) years? Yes

If you answered "yes" to the question above, in addition to providing the information requested below, you are required to provide supporting documents to prove your residency for the past seven (7) years. See Section B, Appendix 3 for acceptable forms of proof.

Provide the address of your primary residence(s) for the past seven (7) years. Identify the dates (month and year) you resided at each listed location:

 Sept 2001 - Present

Tax Liability

Do you have any outstanding tax delinquencies owed to the State of Arkansas: No

If you answered "yes" to the previous question, please explain the nature of any delinquencies:

Other Financial Liabilities

Are you a party to any legal proceedings where damages, fines, or civil penalties may reasonably be expected to exceed \$500,000 above any insurance coverage available to cover the claim?

No

If the answer to the above question is “yes”, attach a statement describing the litigation, including the title and docket number of the litigation, the name and location of the court in which it is pending, the identity of all parties to the litigation, the general nature of the claims being made and the impact an unfavorable opinion may have on your ability to finance and operate the proposed cultivation facility. Any documents submitted in response to this requirement must be labeled with “Section B, Other Financial Liabilities”.

Regulatory History

Have you, or has any entity over which you exercised management or control, ever had any fines or other penalties over \$10,000 assessed by any regulatory agency? **No**

If the answer above is “yes”, attach a statement providing the details of such fines or penalties. Any documents submitted in response to this requirement must be labeled with “Section B, Regulatory History”.

Professional Licensure

Do you presently hold any type of professional license? **Yes**

If yes, identify the type of license and license number **Registered Dietitian Nutritionist: 808890**
Licensed Arkansas Dietician: 526

Is the license in good standing? **Yes**

Certification

I, **Kathryne Deane Peck**, certify that the information provided in this form and its attachments is complete and accurate. I understand that any misstatement or concealment of fact may be grounds for refusal of application or revocation of license if later disclosed.

Signed this **31** day of **July**, **2017**.



Signature of Applicant, Owner, Officer, or Board Member

Subscribed and sworn to before me this 31st day of July, 2017.

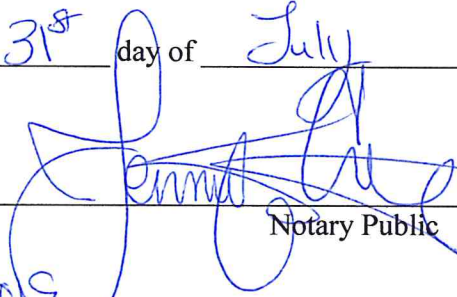

Notary Public

My Commission Expires: 4/6/2019

JENNIFER CATE
HOT SPRING COUNTY
NOTARY PUBLIC - ARKANSAS
My Commission Expires April 06, 2019
Commission No. 12370666

Section B, Appendix 2

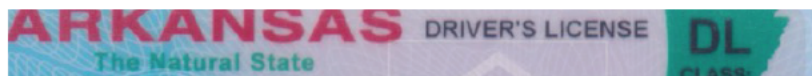

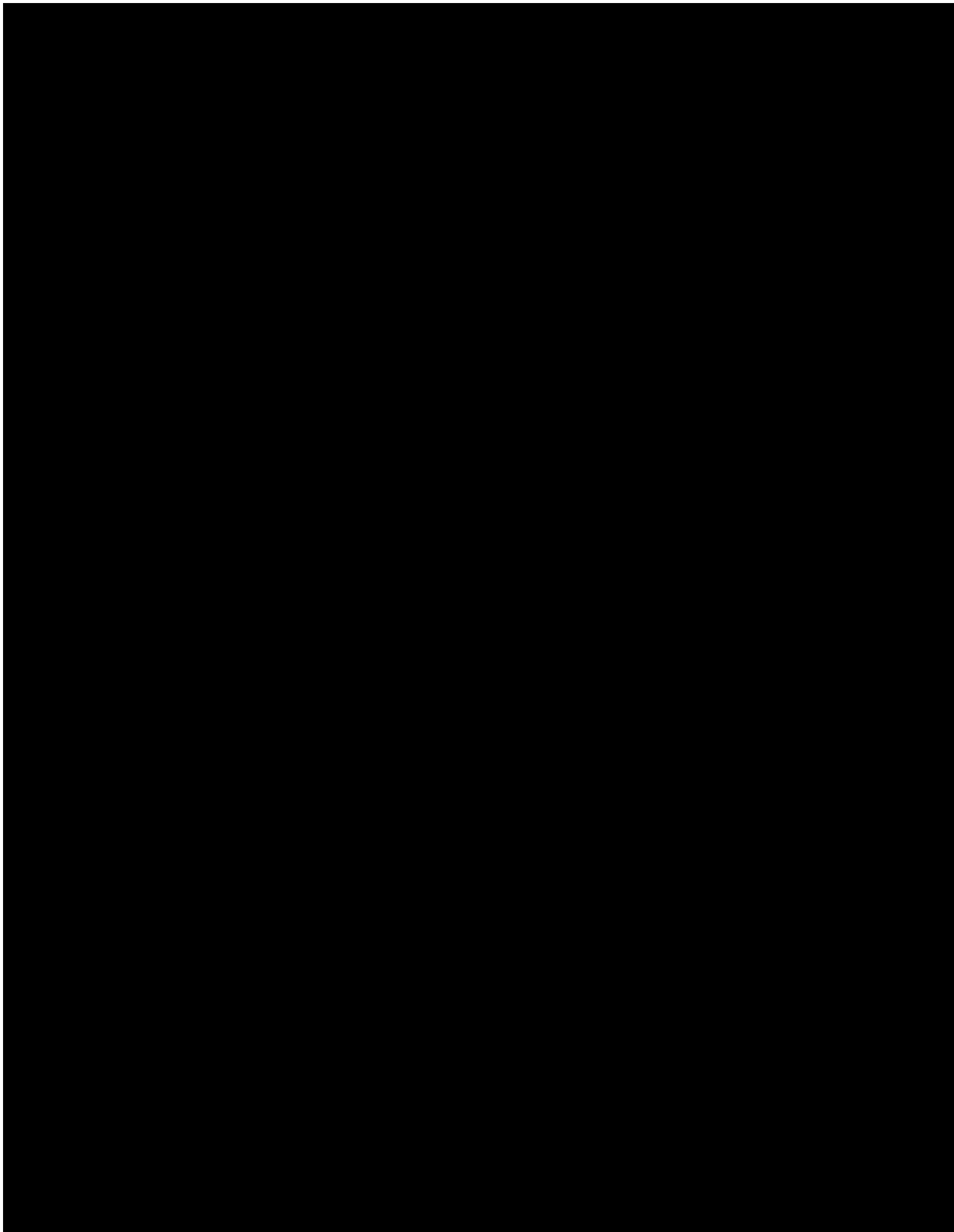

Parcel History Report

Section B, Appendix 3

Created: 8/3/2017 7:45:53 PM

Basic Information	
Parcel Number:	53R0320002501
County Name:	Pulaski County
Owners Name:	PECK CHILDREN TRUST
Billing Name:	PECK CHILDREN TRUST
Billing Address:	[REDACTED]
City, State, Zip:	[REDACTED]

Assessment History					
Year	Assessed Land	Assessed Building	Total Assessed	Taxable Value	
2017	12,600	77,040	89,640	62,545	
2017	10,540	72,970	83,510	62,245	
2016	10,540	72,970	83,510	59,285	
2015	10,540	72,970	83,510	56,915	
2014	10,540	72,970	83,510	54,545	
2013	10,540	72,970	83,510	52,175	
2012	10,540	72,970	83,510	49,805	
2012	10,540	72,970	83,510	52,175	
2011	24,300	51,100	75,400	45,465	
2011	24,300	51,100	75,400	47,435	
2010	24,300	51,100	75,400	43,485	
2009	46,260	59,885	106,145	106,145	
2008	46,264	0	46,264	39,535	
2007	46,264	0	46,264	39,536	
2006	46,264	62,480	108,744	39,537	
2005	15,243	24,297	39,540	39,539	
2004	269	63,750	64,019	280	
2002	239	0	239	239	

Ownership History						
Date	Price	Grantor	Grantee	Book	Page	Deed Type
6/14/2005	0	PECK TR TO PECK FM LTD PTN LLL		05	050267	TRD (Treasurer's Deed)
5/3/2005	0	PECK TR TO PECK RV TR		05	037695	TRD (Treasurer's Deed)
4/26/2001	1	PECK TO TRUST		01	030328	QCD ()
12/1/1990	1			90	70087	DEED (Deed)

State of Arkansas }
 } *Scilicet:*
County of Pulaski }

Sworn Affidavit of

Beverly Joyce Peck being first duly sworn and put upon oath to tell the truth, deposeth and sayeth as follow:

- My name is Beverly Joyce Peck and I am an individual over the age of eighteen (18) years, competent to make this affidavit. I make this affidavit based upon my personal knowledge of the facts contained herein.
- I am the Trustee of The Peck Children Trust which owns property located at [REDACTED] (the "Property").
- I am personally familiar with Kathyne Deane Peck, who has lived at the Property from September 2001 until Present. She has used the Property as her primary residence during this time.

AND FURTHER AFFIANT SAYETH NOT.

SIGNATURE:

Beverly Joyce Peck Trustee
Beverly Joyce Peck, Trustee, The Peck
Children Trust, Affiant

Verification

Before me personally appeared the affiant, Beverly Joyce Peck, to me well known or successfully proven to be the person stated above, who indicated that he/she has executed the foregoing affidavit under oath and for the purposes stated herein, this 13th day of September, 2017.

IN WITNESS WHEREOF, I have hereunder set my hand and official seal as a notary public in and for the State of Arkansas.

Jennifer Cate
NOTARY PUBLIC

My commission expires: 4/6/2019



Individual Voting History Report

Peck, Kathryne Deane

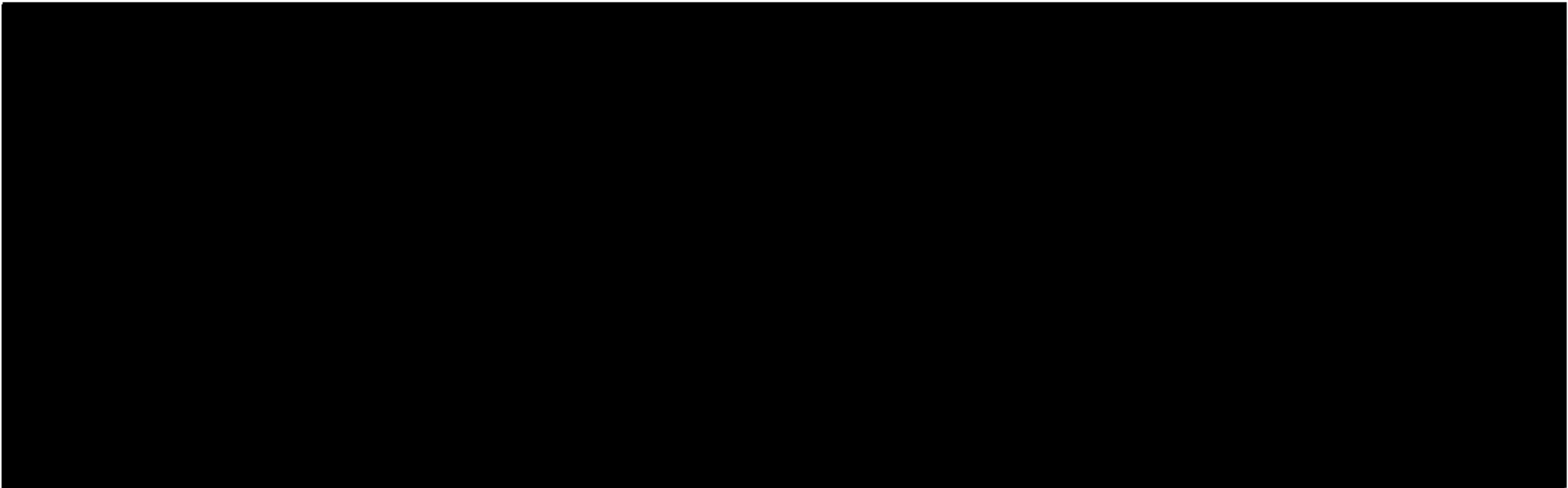

Certified This 12th Day of September 2017
By Rebecca D. Lynn
Deputy Clerk



Debrah C. Clark
BY _____

Continued This _____ Day of _____ 20__



ARKANSAS STATE POLICE

Arkansas Criminal History Report

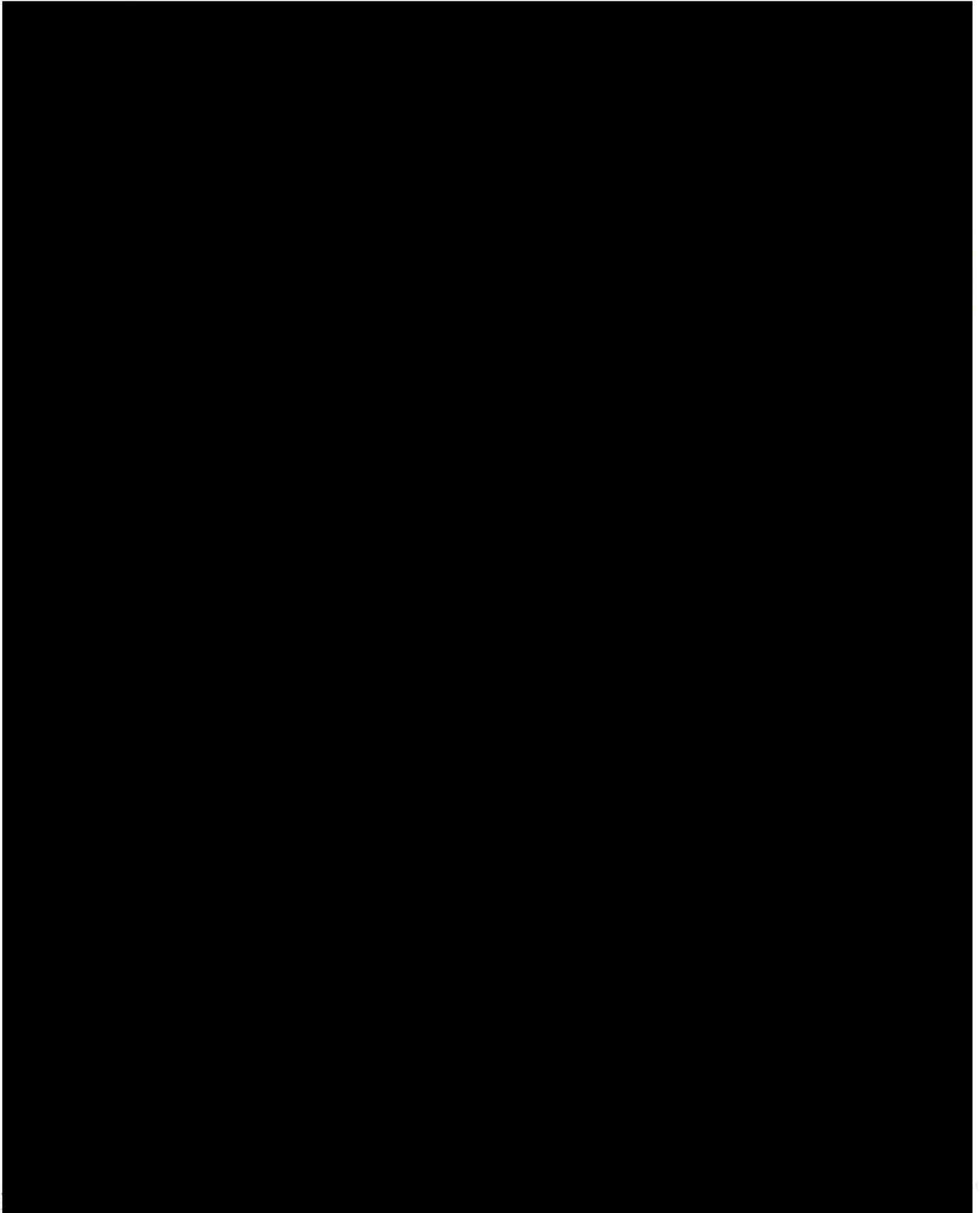

APPLICATION FOR MEDICAL MARIJUANA CULTIVATION FACILITY

SECTION B. Applicant, Owner, Officer, or Board Member Disclosure Statement

Identify your affiliation with the proposed cultivation facility (Applicant, Owner, Officer, Board Member?) Include your percentage of equity ownership in the facility, if any.

Affiliation: Applicant, Owner, Chief Medical Officer

Percentage of Equity Ownership: 10.07%

Legal Name

*In addition to the information below, you are required to provide supporting documents to prove your legal name. See Section B, Appendix 1 for acceptable forms of proof.

Last Name Schlesinger

First Name Kelli

Middle Name Plumlee

Maiden Name (if applicable) Plumlee

Alias(es) or former names Kelli Dianne Plumlee, Kelli Dianne Schlesinger

SSN [REDACTED]

Date of Birth

*In addition to providing your date of birth, you are required to provide supporting documents to prove your date of birth. See Section B, Appendix 2 for acceptable forms of proof.

Date of Birth [REDACTED]

Contact Information

Mailing Address [REDACTED]

Phone Number (primary contact number) [REDACTED]

Email Address drk@legacyneuro.com

Residency

Are you an Arkansas resident? Yes

If you are not an Arkansas resident, please identify your primary place of residence.

Have you been an Arkansas resident for the past seven (7) years? Yes

If you answered “yes” to the question above, in addition to providing the information requested below, you are required to provide supporting documents to prove your residency for the past seven (7) years. See Section B, Appendix 3 for acceptable forms of proof.

Provide the address of your primary residence(s) for the past seven (7) years. Identify the dates (month and year) you resided at each listed location:

 Jan 2007

Tax Liability

Do you have any outstanding tax delinquencies owed to the State of Arkansas: No

If you answered “yes” to the previous question, please explain the nature of any delinquencies:

Other Financial Liabilities

Are you a party to any legal proceedings where damages, fines, or civil penalties may reasonably be expected to exceed \$500,000 above any insurance coverage available to cover the claim?

No

If the answer to the above question is “yes”, attach a statement describing the litigation, including the title and docket number of the litigation, the name and location of the court in which it is pending, the identity of all parties to the litigation, the general nature of the claims being made and the impact an unfavorable opinion may have on your ability to finance and operate the proposed cultivation facility. Any documents submitted in response to this requirement must be labeled with “Section B, Other Financial Liabilities”.

Regulatory History

Have you, or has any entity over which you exercised management or control, ever had any fines or other penalties over \$10,000 assessed by any regulatory agency? No

If the answer above is “yes”, attach a statement providing the details of such fines or penalties. Any documents submitted in response to this requirement must be labeled with “Section B, Regulatory History”.

Professional Licensure

Do you presently hold any type of professional license? Yes

If yes, identify the type of license and license number Ark Physician Lic E-7545, DEA [REDACTED]

Is the license in good standing? Yes

Certification

I, Dr. Kelli Schlesinger, certify that the information provided in this form and its attachments is complete and accurate. I understand that any misstatement or concealment of fact may be grounds for refusal of application or revocation of license if later disclosed.

Signed this 30th day of July, 2017.

[Handwritten Signature]

Signature of Applicant, Owner, Officer, or Board Member

Subscribed and sworn to before me this 30th day of July, 2017.

[Handwritten Signature]
Notary Public

My Commission Expires: 4/6/2019

JENNIFER CATE
HOT SPRING COUNTY
NOTARY PUBLIC - ARKANSAS
My Commission Expires April 06, 2019
Commission No. 12370886

Section B, Appendix 1

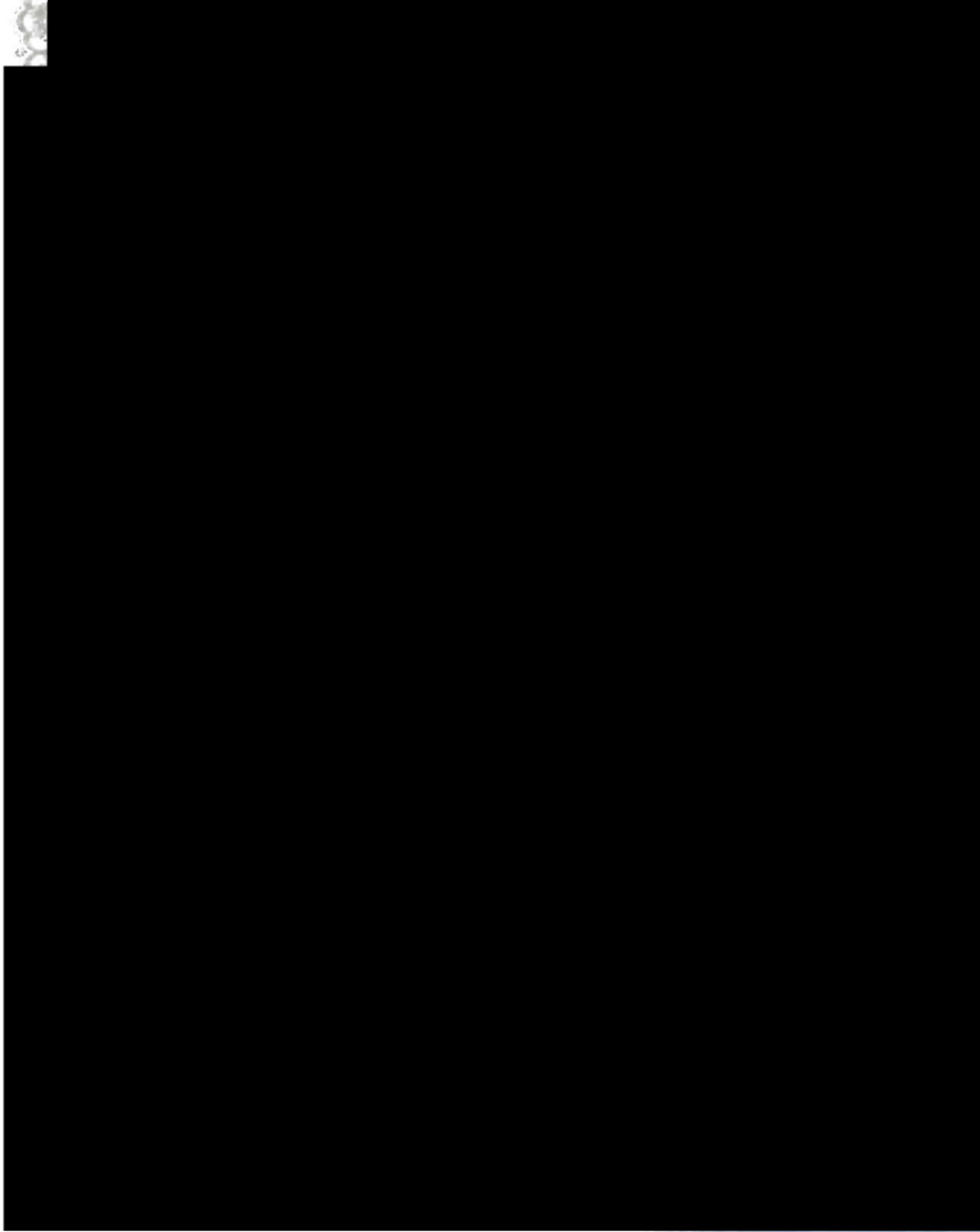

Section B, Appendix 2



Parcel History Report

Section B, Appendix 3

Created: 8/7/2017 11:11:59 AM

Basic Information	
Parcel Number:	53L0260150800
County Name:	Pulaski County
Owners Name:	SCHLESINGER SCOTT MICHAEL
Billing Name:	SCHLESINGER SCOTT MICHAEL
Billing Address:	[REDACTED]
City, State, Zip:	[REDACTED]

Assessment History				
Year	Assessed Land	Assessed Building	Total Assessed	Taxable Value
2017	35,670	67,940	103,610	103,610
2012	27,200	88,740	115,940	115,940
2012	27,200	106,220	133,420	133,417
2011	30,000	98,177	128,177	128,177
2010	30,000	98,177	128,177	128,177
2009	30,000	98,177	128,177	121,890
2008	28,750	83,536	112,286	112,286
2007	28,750	83,536	112,286	112,286
2006	28,750	83,536	112,286	112,286
2005	23,148	82,068	105,216	105,216
2004	25,000	89,580	114,580	97,126
2002	23,196	0	23,196	23,196

Ownership History						
Date	Price	Grantor	Grantee	Book	Page	Deed Type
1/1/1997	2			97	2636	DEED (Deed)
12/1/1994	124,000			94	83206	DEED (Deed)

Individual Voting History Report

Schlesinger, Kelli Dianne

[REDACTED]
[REDACTED]

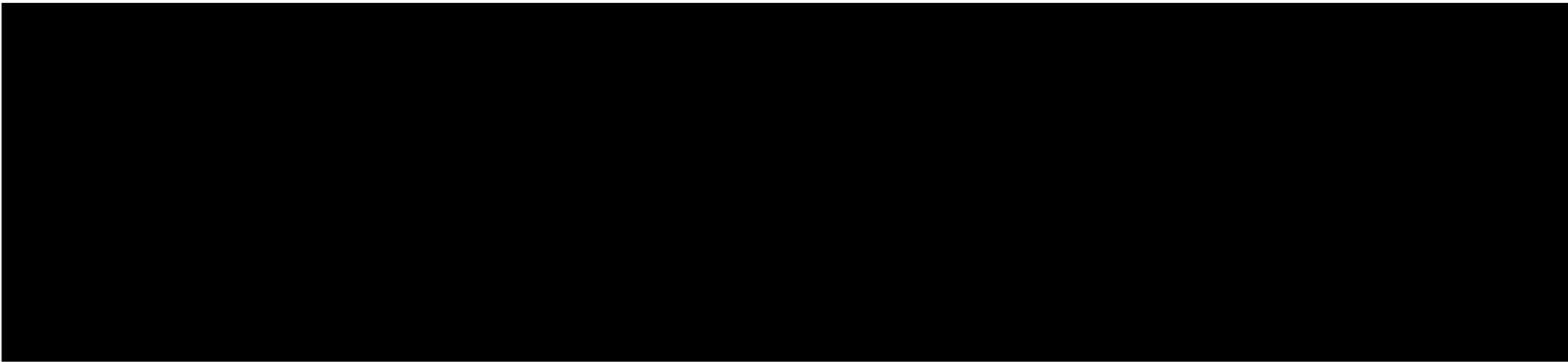

Certified This 12th Day of September 2017
By Rebecca A. Lynn
Deputy Clerk



Section B - Professional Licensure

CONTROLLED SUBSTANCE REGISTRATION CERTIFICATE UNITED STATES DEPARTMENT OF JUSTICE DRUG ENFORCEMENT ADMINISTRATION WASHINGTON, D.C. 20537		
DEA REGISTRATION NUMBER	THIS REGISTRATION EXPIRES	FEE PAID
[REDACTED]	02-28-2018	\$731
SCHEDULES	BUSINESS ACTIVITY	DATE ISSUED
2,2N,3 3N,4,5	PRACTITIONER	01-05-2015
SCHLESINGER, KELLI, D, MD 8201 Cantrell Rd. SUITE 265 LITTLE ROCK, AR 72227		
Sections 304 and 1008 (21 U.S.C. 824 and 958) of the Controlled Substances Act of 1970, as amended, provide that the Attorney General may revoke or suspend a registration to manufacturer, distribute, dispense, import or export a controlled substance.		
THIS CERTIFICATE IS NOT TRANSFERABLE ON CHANGE OF OWNERSHIP, CONTROL, LOCATION, OR BUSINESS ACTIVITY, AND IS NOT VALID AFTER THE EXPIRATION DATE.		

CONTROLLED SUBSTANCE REGISTRATION CERTIFICATE UNITED STATES DEPARTMENT OF JUSTICE DRUG ENFORCEMENT ADMINISTRATION WASHINGTON, D.C. 20537		
DEA REGISTRATION NUMBER	THIS REGISTRATION EXPIRES	FEE PAID
[REDACTED]	02-28-2018	\$731
SCHEDULES	BUSINESS ACTIVITY	DATE ISSUED
2,2N,3 3N,4,5	PRACTITIONER	01-05-2015
SCHLESINGER, KELLI, D, MD 8201 Cantrell Rd. SUITE 265 LITTLE ROCK, AR 72227		
Sections 304 and 1008 (21 U.S.C. 824 and 958) of the Controlled Substances Act of 1970, as amended, provide that the Attorney General may revoke or suspend a registration to manufacture, distribute, dispense, import or export a controlled substance.		
THIS CERTIFICATE IS NOT TRANSFERABLE ON CHANGE OF OWNERSHIP, CONTROL, LOCATION, BUSINESS ACTIVITY, OR VALID AFTER THE EXPIRATION DATE.		

Form DEA-223 (05/04)





ARKANSAS STATE MEDICAL BOARD

1401 West Capitol, Suite 340, Little Rock, Arkansas 72201 (501) 296-1802 FAX: (501) 603-3555

www.armedicalboard.org

Section B - Professional Licensure

Detailed License Verification

Queried on: Tuesday, August 01, 2017 at: 3:47 PM

General Information

Name: Kelli D. Schlesinger, M.D.
Specialty: Neurology

Address Information

Mailing Address: 8201 Cantrell Road
Address 2: Suite 265
City/State/Zip: Little Rock, AR 72227
Phone: (501) 661-0818
Fax: (501) 897-6468

License Information

License Number: E-7545
Original Issue Date: 6/1/2012
Expiration Date: 3/31/2018
Basis: Exam
License Status: Active
License Category: Unlimited

No Information Found for: License Board History

ARKANSAS STATE POLICE

Arkansas Criminal History Report

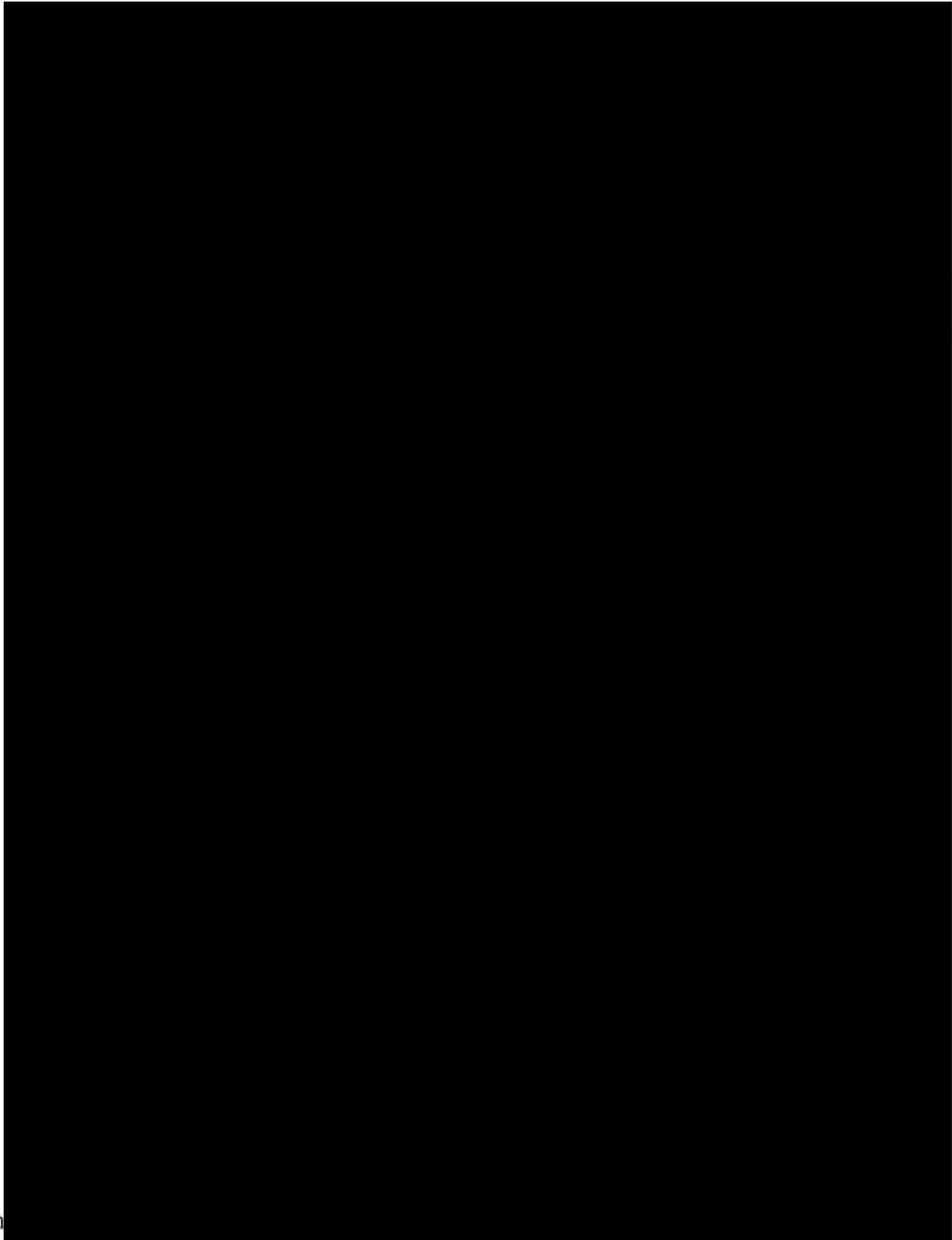

h

APPLICATION FOR MEDICAL MARIJUANA CULTIVATION FACILITY

SECTION B. Applicant, Owner, Officer, or Board Member Disclosure Statement

Identify your affiliation with the proposed cultivation facility (Applicant, Owner, Officer, Board Member?) Include your percentage of equity ownership in the facility, if any.

Affiliation: Owner, Vice President IT and Business Development, Board Member

Percentage of Equity Ownership: 4.46%

Legal Name

*In addition to the information below, you are required to provide supporting documents to prove your legal name. See Section B, Appendix 1 for acceptable forms of proof.

Last Name deBin

First Name Robert

Middle Name Wayne

Maiden Name (if applicable) _____

Alias(es) or former names _____

SSN [REDACTED]

Date of Birth

*In addition to providing your date of birth, you are required to provide supporting documents to prove your date of birth. See Section B, Appendix 2 for acceptable forms of proof.

Date of Birth [REDACTED]

Contact Information

Mailing Address PO Box 26836, Little Rock, AR 72221

Phone Number (primary contact number) [REDACTED]

Email Address robert.debin@gmail.com

Residency





Are you an Arkansas resident? Yes

If you are not an Arkansas resident, please identify your primary place of residence.

Have you been an Arkansas resident for the past seven (7) years? Yes

If you answered "yes" to the question above, in addition to providing the information requested below, you are required to provide supporting documents to prove your residency for the past seven (7) years. See Section B, Appendix 3 for acceptable forms of proof.

Provide the address of your primary residence(s) for the past seven (7) years. Identify the dates (month and year) you resided at each listed location:

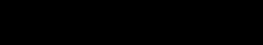
September 2009 to May 2011 : 
May 2011 to June 2013 : 
June 2013 to November 2013 : 
November 2013 to April 2014: 
April 2014 to Present : 

Tax Liability

Do you have any outstanding tax delinquencies owed to the State of Arkansas: No

If you answered "yes" to the previous question, please explain the nature of any delinquencies:

Other Financial Liabilities

Are you a party to any legal proceedings where damages, fines, or civil penalties may reasonably be expected to exceed \$500,000 above any insurance coverage available to cover the claim?

No

If the answer to the above question is “yes”, attach a statement describing the litigation, including the title and docket number of the litigation, the name and location of the court in which it is pending, the identity of all parties to the litigation, the general nature of the claims being made and the impact an unfavorable opinion may have on your ability to finance and operate the proposed cultivation facility. Any documents submitted in response to this requirement must be labeled with “Section B, Other Financial Liabilities”.

Regulatory History

Have you, or has any entity over which you exercised management or control, ever had any fines or other penalties over \$10,000 assessed by any regulatory agency? **No**

If the answer above is “yes”, attach a statement providing the details of such fines or penalties. Any documents submitted in response to this requirement must be labeled with “Section B, Regulatory History”.

Professional Licensure

Do you presently hold any type of professional license? **No**

If yes, identify the type of license and license number _____

Is the license in good standing? _____

Certification

I, Robert W. deBin, certify that the information provided in this form and its attachments is complete and accurate. I understand that any misstatement or concealment of fact may be grounds for refusal of application or revocation of license if later disclosed.

Signed this 31 day of July, 2017.

Robert W. deBin

Signature of Applicant, Owner, Officer, or Board Member

Subscribed and sworn to before me this 31st day of July, 2017.

Jennifer Cate
Notary Public

My Commission Expires: 4/6/2019

JENNIFER CATE
HOT SPRING COUNTY
NOTARY PUBLIC - ARKANSAS
My Commission Expires April 06, 2019
Commission No. 12370986

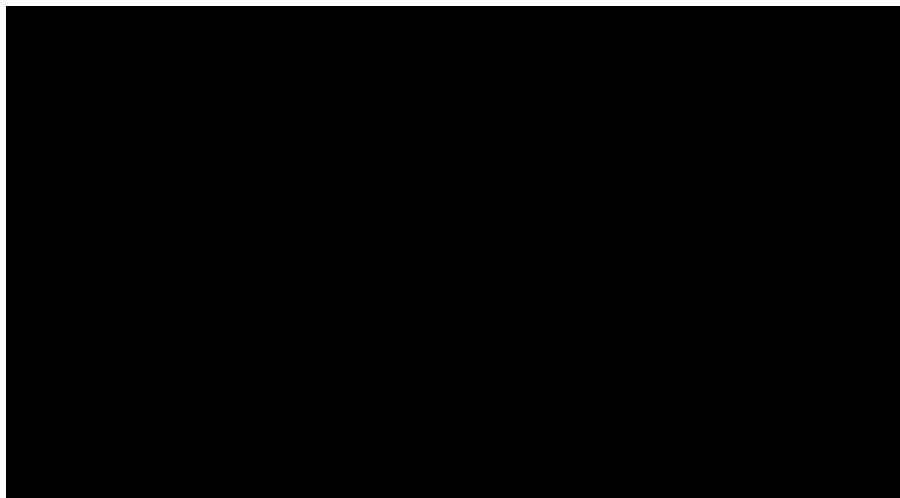
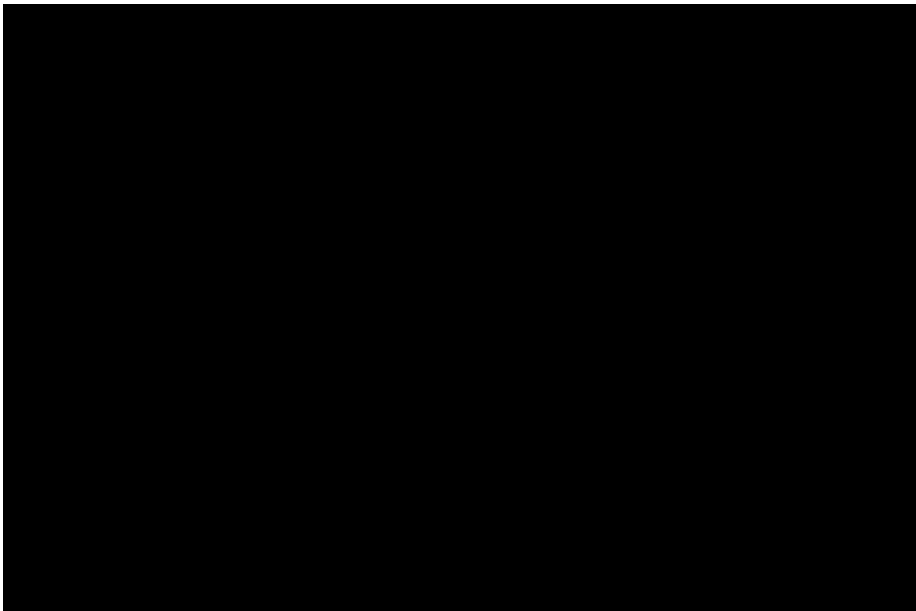

State of Arkansas }
 } *Scilicet:*
County of Pulaski }

Sworn Affidavit of
Mason Henry

Mason Henry being first duly sworn and put upon oath to tell the truth, depose and sayeth as follow:

1. My name is Mason Henry and I am an individual over the age of eighteen (18) years, competent to make this affidavit. I make this affidavit based upon my personal knowledge of the facts contained herein.
2. I own, owned, or leased property located at [REDACTED] (the "Property").
3. I am personally familiar with Robert deBin, who was a tenant at the Property from November 2013 until April 2014. To the best of my knowledge, he/she used the Property as his/her primary residence during that time.

AND FURTHER AFFIANT SAYETH NOT.

SIGNATURE:

Mason Henry
_____, Affiant

VERIFICATION

Before me personally appeared the affiant, Mason Henry to me well known or successfully proven to be the person stated above, who indicated that he/she has executed the foregoing affidavit under oath and for the purposes stated herein, this 29 day of July, 2017.

IN WITNESS WHEREOF, I have hereunder set my hand and official seal as a notary public in and for the State of Arkansas.

[Signature]
NOTARY PUBLIC

My commission expires:

5/28/2025



Certified This 2nd Day of September 2017

By Rebecca D. Lynn
Deputy Clerk



PCI Security Standards Council, LLC

acknowledges that

Robert deBin

RockIT City Solutions, Inc, dba CLU Solutions

has successfully fulfilled the requirements for

Qualified Integrators and Resellers (QIR)TM

on this date

23 October 2015



PCI QIR Code: 600-106

A handwritten signature in black ink, appearing to read "Stephen W. Orfei".

Stephen W. Orfei, General Manager
PCI SSC

This designation is subject to re-qualification every three years and suspension or revocation for failure to comply with any applicable requirement set forth in the QIR Qualification Requirements.

**Section B - Professional
Licensure**

ARKANSAS STATE POLICE

Arkansas Criminal History Report

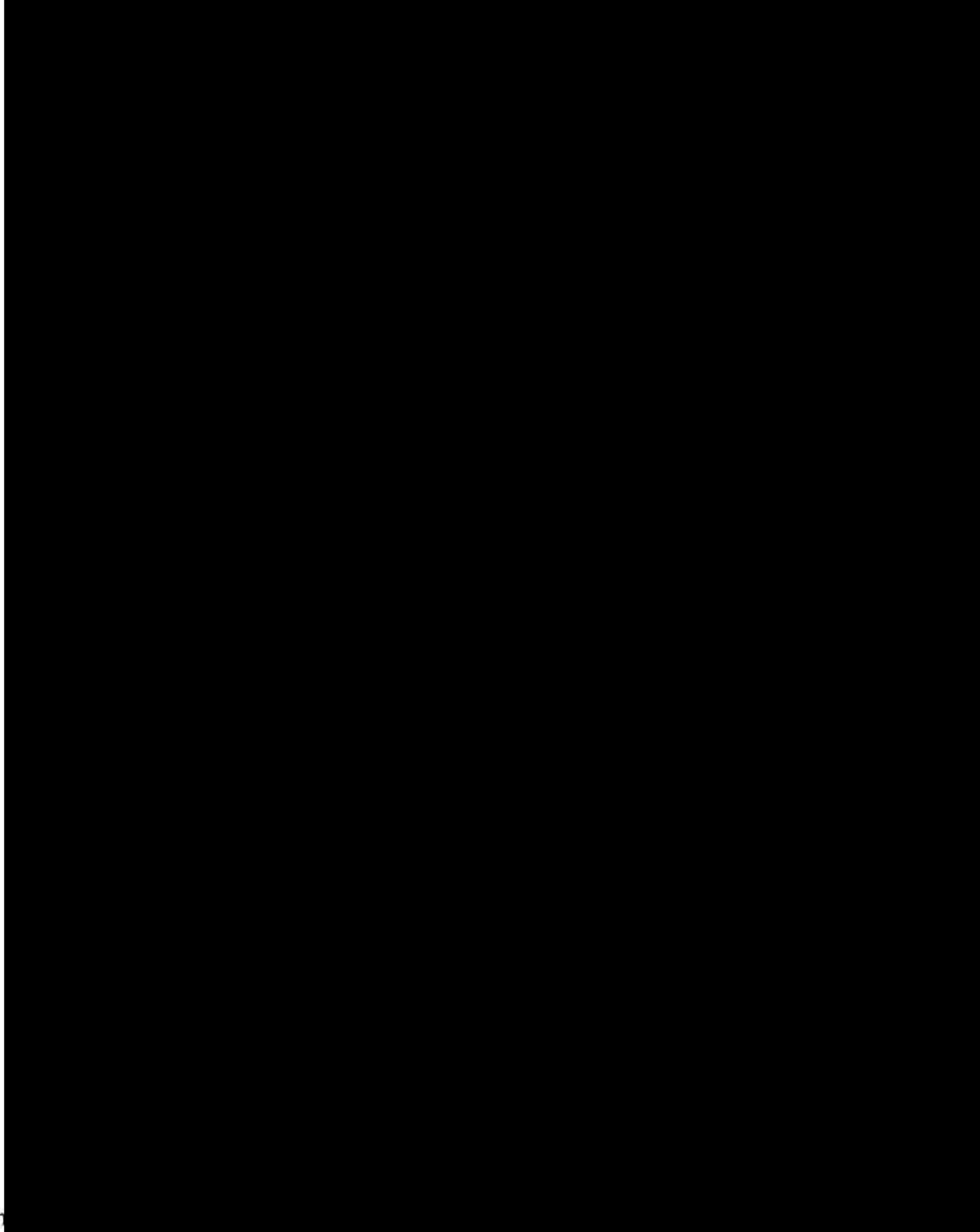

h

APPLICATION FOR MEDICAL MARIJUANA CULTIVATION FACILITY

SECTION B. Applicant, Owner, Officer, or Board Member Disclosure Statement

Identify your affiliation with the proposed cultivation facility (Applicant, Owner, Officer, Board Member?) Include your percentage of equity ownership in the facility, if any.

Affiliation: Applicant, Owner,

Percentage of Equity Ownership: 5.66%

Legal Name

*In addition to the information below, you are required to provide supporting documents to prove your legal name. See Section B, Appendix 1 for acceptable forms of proof.

Last Name Scott

First Name Schlesinger

Middle Name Michael

Maiden Name (if applicable) _____

Alias(es) or former names _____

SSN [REDACTED]

Date of Birth

*In addition to providing your date of birth, you are required to provide supporting documents to prove your date of birth. See Section B, Appendix 2 for acceptable forms of proof.

Date of Birth [REDACTED]

Contact Information

Mailing Address [REDACTED]

Phone Number (primary contact number) [REDACTED]

Email Address drs@legacyneuro.com

Residency

Are you an Arkansas resident? Yes

If you are not an Arkansas resident, please identify your primary place of residence.

Have you been an Arkansas resident for the past seven (7) years? Yes

If you answered “yes” to the question above, in addition to providing the information requested below, you are required to provide supporting documents to prove your residency for the past seven (7) years. See Section B, Appendix 3 for acceptable forms of proof.

Provide the address of your primary residence(s) for the past seven (7) years. Identify the dates (month and year) you resided at each listed location:

 Dec 1996 to Present

Tax Liability

Do you have any outstanding tax delinquencies owed to the State of Arkansas: No

If you answered “yes” to the previous question, please explain the nature of any delinquencies:

Other Financial Liabilities

Are you a party to any legal proceedings where damages, fines, or civil penalties may reasonably be expected to exceed \$500,000 above any insurance coverage available to cover the claim?

No

If the answer to the above question is “yes”, attach a statement describing the litigation, including the title and docket number of the litigation, the name and location of the court in which it is pending, the identity of all parties to the litigation, the general nature of the claims being made and the impact an unfavorable opinion may have on your ability to finance and operate the proposed cultivation facility. Any documents submitted in response to this requirement must be labeled with “Section B, Other Financial Liabilities”.

Regulatory History

Have you, or has any entity over which you exercised management or control, ever had any fines or other penalties over \$10,000 assessed by any regulatory agency? No

If the answer above is “yes”, attach a statement providing the details of such fines or penalties. Any documents submitted in response to this requirement must be labeled with “Section B, Regulatory History”.

Professional Licensure

Do you presently hold any type of professional license? Yes

If yes, identify the type of license and license number Ark Medical Lic# C-7144, DEA [REDACTED]

Is the license in good standing? Yes

Certification

I, Dr. Scott Schlesinger, certify that the information provided in this form and its attachments is complete and accurate. I understand that any misstatement or concealment of fact may be grounds for refusal of application or revocation of license if later disclosed.

Signed this 30th day of July, _____.

Scott Schlesinger
Signature of Applicant, Owner, Officer, or Board Member

Subscribed and sworn to before me this 30th day of July, 2017.

Jennifer Cate
Notary Public

My Commission Expires: 4/6/2019

JENNIFER CATE
HOT SPRING COUNTY
NOTARY PUBLIC - ARKANSAS
My Commission Expires April 06, 2019
Commission No. 12370686

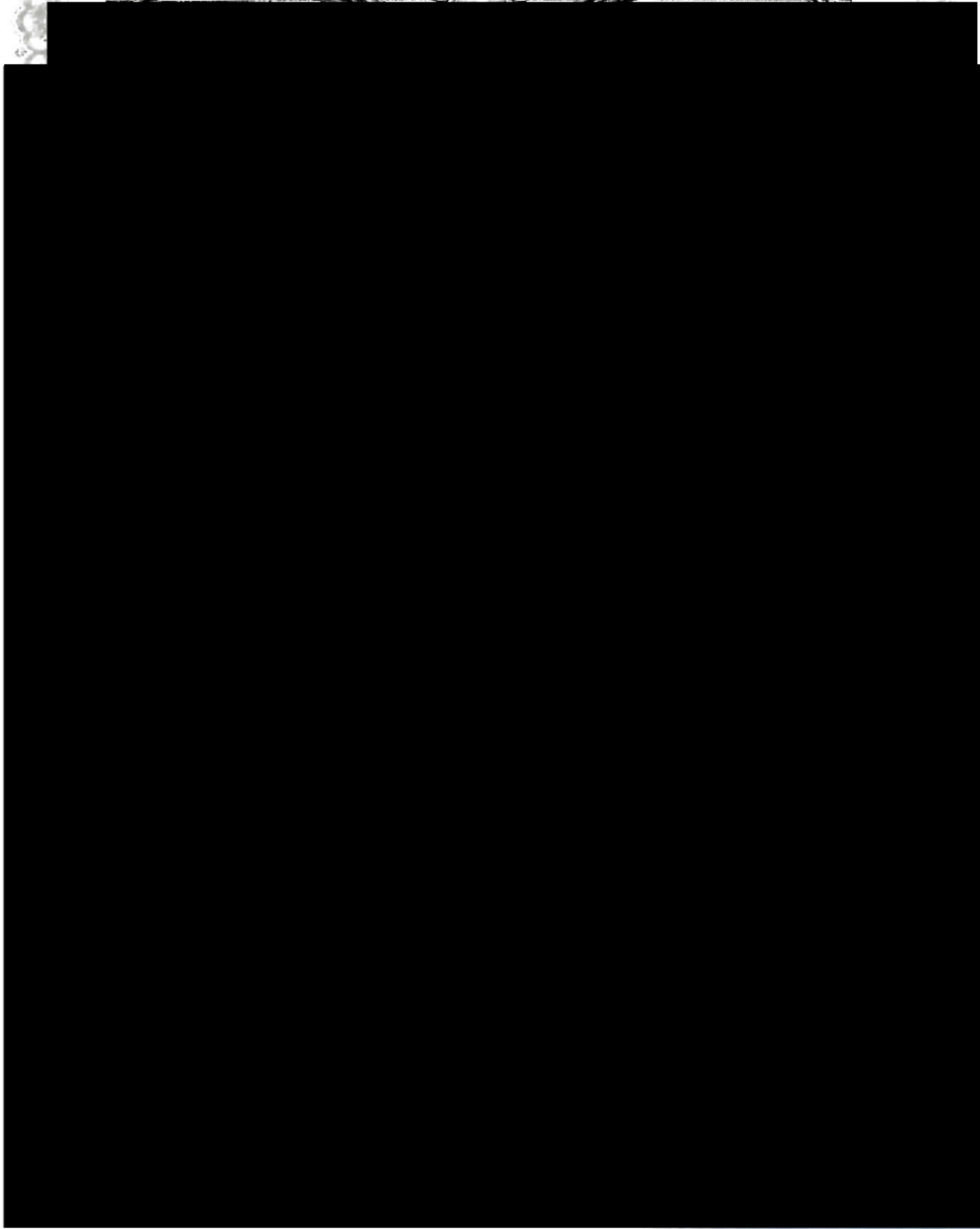

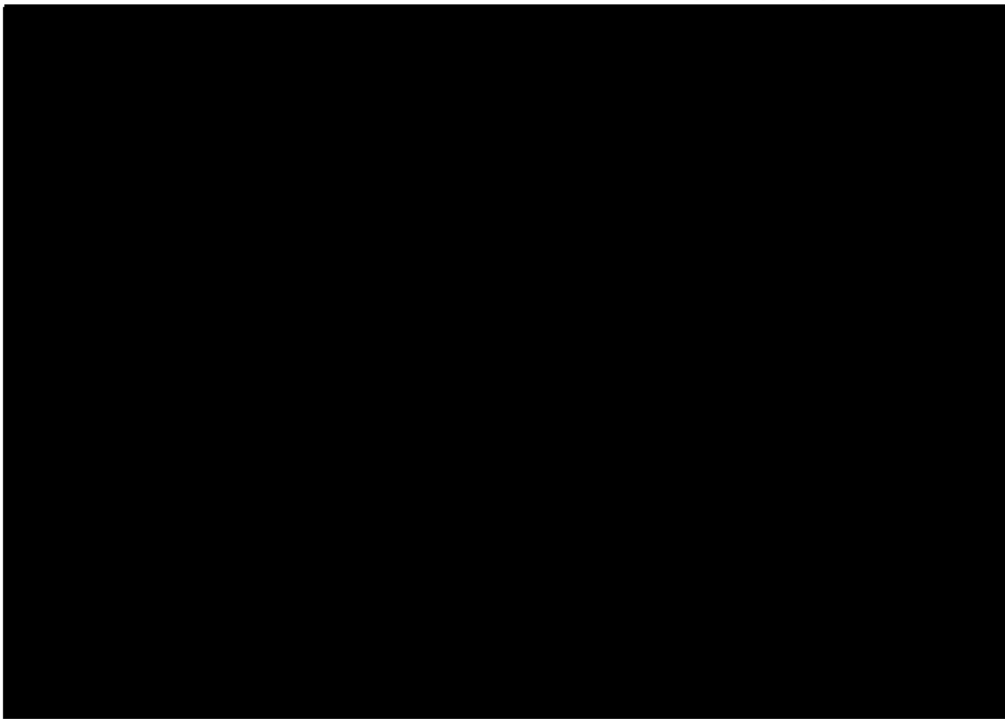

Parcel History Report

Created: 8/7/2017 11:11:59 AM

Basic Information	
Parcel Number:	53L0260150800
County Name:	Pulaski County
Owners Name:	SCHLESINGER SCOTT MICHAEL
Billing Name:	SCHLESINGER SCOTT MICHAEL
Billing Address:	[REDACTED]
City, State, Zip:	[REDACTED]

Assessment History

Year	Assessed Land	Assessed Building	Total Assessed	Taxable Value
2017	35,670	67,940	103,610	103,610
2012	27,200	88,740	115,940	115,940
2012	27,200	106,220	133,420	133,417
2011	30,000	98,177	128,177	128,177
2010	30,000	98,177	128,177	128,177
2009	30,000	98,177	128,177	121,890
2008	28,750	83,536	112,286	112,286
2007	28,750	83,536	112,286	112,286
2006	28,750	83,536	112,286	112,286
2005	23,148	82,068	105,216	105,216
2004	25,000	89,580	114,580	97,126
2002	23,196	0	23,196	23,196

Ownership History

Date	Price	Grantor	Grantee	Book	Page	Deed Type
1/1/1997	2			97	2636	DEED (Deed)
12/1/1994	124,000			94	83206	DEED (Deed)

Section B - Professional Licensure

<p align="center">CONTROLLED SUBSTANCE REGISTRATION CERTIFICATE UNITED STATES DEPARTMENT OF JUSTICE DRUG ENFORCEMENT ADMINISTRATION WASHINGTON, D.C. 20537</p>		
DEA REGISTRATION NUMBER	THIS REGISTRATION EXPIRES	FEE PAID
[REDACTED]	02-28-2019	\$731
SCHEDULES	BUSINESS ACTIVITY	DATE ISSUED
2,2N,3 3N,4,5	PRACTITIONER	01-11-2016
SCHLESINGER, SCOTT M MD ARKANSAS NEUROSURGERY CLINIC, P.A. 5800 W 10TH ST., STE 205 LITTLE ROCK, AR 72204		
Sections 304 and 1008 (21 U.S.C. 824 and 958) of the Controlled Substances Act of 1970, as amended, provide that the Attorney General may revoke or suspend a registration to manufacture, distribute, dispense, import or export a controlled substance.		
THIS CERTIFICATE IS NOT TRANSFERABLE ON CHANGE OF OWNERSHIP, CONTROL, LOCATION, OR BUSINESS ACTIVITY, AND IS NOT VALID AFTER THE EXPIRATION DATE.		

<p align="center">CONTROLLED SUBSTANCE REGISTRATION CERTIFICATE UNITED STATES DEPARTMENT OF JUSTICE DRUG ENFORCEMENT ADMINISTRATION WASHINGTON, D.C. 20537</p>		
DEA REGISTRATION NUMBER	THIS REGISTRATION EXPIRES	FEE PAID
[REDACTED]	02-28-2019	\$731
SCHEDULES	BUSINESS ACTIVITY	DATE ISSUED
2,2N,3 3N,4,5	PRACTITIONER	01-11-2016
SCHLESINGER, SCOTT M MD ARKANSAS NEUROSURGERY CLINIC, P.A. 5800 W 10TH ST., STE 205 LITTLE ROCK, AR 72204		
Sections 304 and 1008 (21 U.S.C. 824 and 958) of the Controlled Substances Act of 1970, as amended, provide that the Attorney General may revoke or suspend a registration to manufacture, distribute, dispense, import or export a controlled substance.		
THIS CERTIFICATE IS NOT TRANSFERABLE ON CHANGE OF OWNERSHIP, CONTROL, LOCATION, BUSINESS ACTIVITY, OR VALID AFTER THE EXPIRATION DATE.		

Form DEA-223 (05/04)

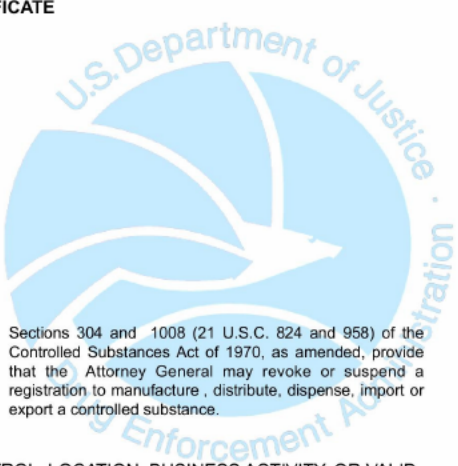



ARKANSAS STATE MEDICAL BOARD

1401 West Capitol, Suite 340, Little Rock, Arkansas 72201 (501) 296-1802 FAX: (501) 603-3555

www.armedicalboard.org

**Section B - Professional
Licensure**

Detailed License Verification

Queried on: Tuesday, August 01, 2017 at: 3:47 PM

General Information

Name: Scott Michael Schlesinger, M.D.
Specialty: Neurological Surgery

Address Information

Mailing Address: 5800 W 10th Street
Address 2: Suite 205
City/State/Zip: Little Rock, AR 72204
Phone: (501) 661-0077
Fax: (501) 664-2749

License Information

License Number: C-7144
Original Issue Date: 8/8/1986
Expiration Date: 9/30/2017
Basis: Exam
License Status: Active
License Category: Unlimited

No Information Found for: License Board History

ARKANSAS STATE POLICE

Arkansas Criminal History Report

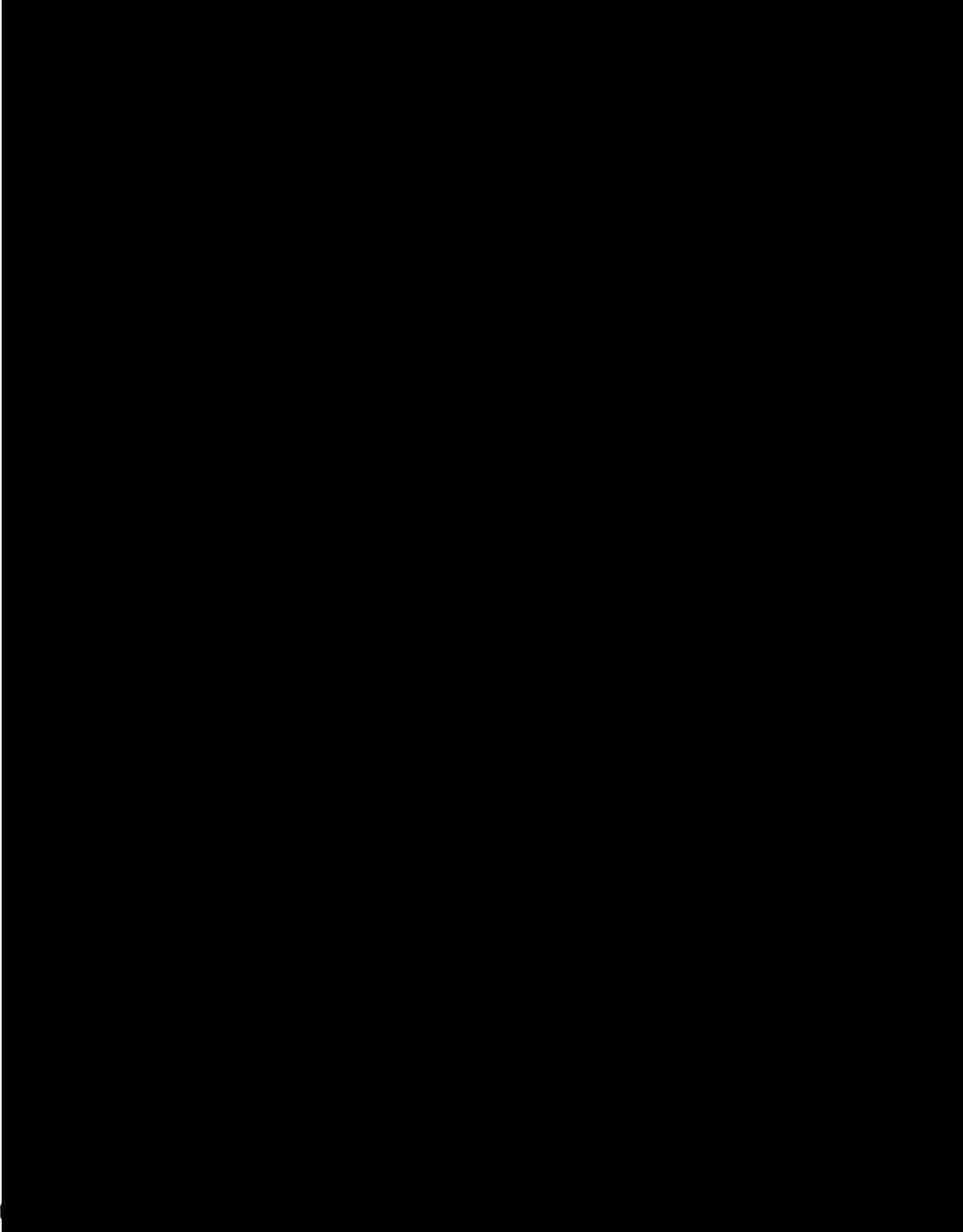

AR
POLICE

APPLICATION FOR MEDICAL MARIJUANA CULTIVATION FACILITY

SECTION B. Applicant, Owner, Officer, or Board Member Disclosure Statement

Identify your affiliation with the proposed cultivation facility (Applicant, Owner, Officer, Board Member?) Include your percentage of equity ownership in the facility, if any.

Affiliation: Owner, Board Member

Percentage of Equity Ownership: 5.66%

Legal Name

*In addition to the information below, you are required to provide supporting documents to prove your legal name. See Section B, Appendix 1 for acceptable forms of proof.

Last Name LaFrance, Jr.

First Name Stephen

Middle Name Lee

Maiden Name (if applicable) _____

Alias(es) or former names _____

SSN [REDACTED]

Date of Birth

*In addition to providing your date of birth, you are required to provide supporting documents to prove your date of birth. See Section B, Appendix 2 for acceptable forms of proof.

Date of Birth [REDACTED]

Contact Information

Mailing Address PO Box 250530

Little Rock, AR 72225

Phone Number (primary contact number) [REDACTED]

Email Address Slafrancejr@dalecp.com

Residency

Are you an Arkansas resident? Yes- entire life

If you are not an Arkansas resident, please identify your primary place of residence.

Have you been an Arkansas resident for the past seven (7) years? Yes

If you answered "yes" to the question above, in addition to providing the information requested below, you are required to provide supporting documents to prove your residency for the past seven (7) years. See Section B, Appendix 3 for acceptable forms of proof.

Provide the address of your primary residence(s) for the past seven (7) years. Identify the dates (month and year) you resided at each listed location:

 (Current)

Tax Liability

Do you have any outstanding tax delinquencies owed to the State of Arkansas: No

If you answered "yes" to the previous question, please explain the nature of any delinquencies:

Other Financial Liabilities

Are you a party to any legal proceedings where damages, fines, or civil penalties may reasonably be expected to exceed \$500,000 above any insurance coverage available to cover the claim?

No

If the answer to the above question is “yes”, attach a statement describing the litigation, including the title and docket number of the litigation, the name and location of the court in which it is pending, the identity of all parties to the litigation, the general nature of the claims being made and the impact an unfavorable opinion may have on your ability to finance and operate the proposed cultivation facility. Any documents submitted in response to this requirement must be labeled with “Section B, Other Financial Liabilities”.

Regulatory History

Have you, or has any entity over which you exercised management or control, ever had any fines or other penalties over \$10,000 assessed by any regulatory agency? NO

If the answer above is “yes”, attach a statement providing the details of such fines or penalties. Any documents submitted in response to this requirement must be labeled with “Section B, Regulatory History”.

Professional Licensure

Do you presently hold any type of professional license? No

If yes, identify the type of license and license number N/A

Is the license in good standing? N/A

Certification

I, Stephen L. LaFrance, Jr, certify that the information provided in this form and its attachments is complete and accurate. I understand that any misstatement or concealment of fact may be grounds for refusal of application or revocation of license if later disclosed.

Signed this 28th day of July, 2017.

Signature of Applicant, Owner, Officer, or Board Member

Subscribed and sworn to before me this 28th day of July,
2017.

Notary Public

My Commission Expires: 04/06/2019

JENNIFER CATE
HOT SPRING COUNTY
NOTARY PUBLIC - ARKANSAS
My Commission Expires April 06, 2019
Commission No. 12370586

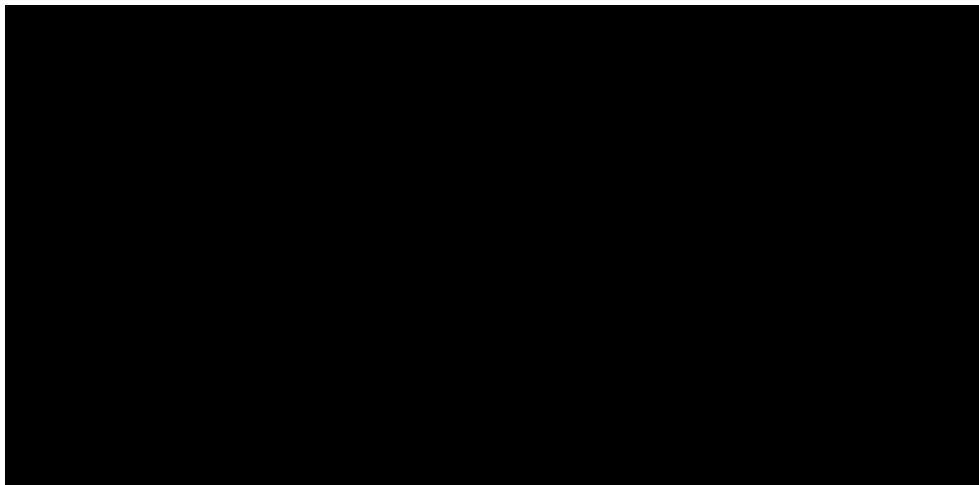
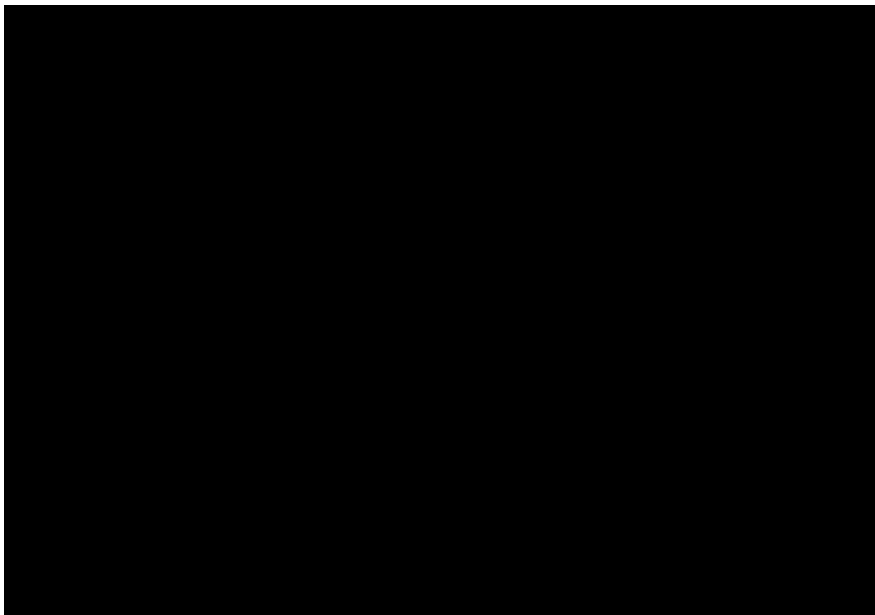

Section B, Appendix 3

Created: 7/28/2017 4:43:47 PM

Parcel History Report

Basic Information	
Parcel Number:	33L0300002000
County Name:	Pulaski County
Owners Name:	MACE PROPERTIES LLC
Billing Name:	MACE PROPERTIES LLC
Billing Address:	[REDACTED]
City, State, Zip:	[REDACTED]

Assessment History

Year	Assessed Land	Assessed Building	Total Assessed	Taxable Value
2017	200,000	288,830	488,830	488,830
2017	120,000	263,740	383,740	383,740
2014	120,000	263,740	383,740	383,740
2013	120,000	263,740	383,740	383,740
2012	120,000	263,740	383,740	371,180
2012	84,000	216,100	300,100	300,100
2012	84,000	220,270	304,270	304,270
2010	60,000	293,500	353,500	353,500
2009	60,000	293,500	353,500	353,500
2008	60,000	275,764	335,764	335,764
2007	60,000	275,764	335,764	173,578
2006	60,000	261,976	321,976	173,579
2005	50,172	123,408	173,580	173,580
2004	53,800	130,780	184,580	173,580
2003	53,800	119,780	173,580	173,580
2002	39,516	0	39,516	39,516

Ownership History

Date	Price	Grantor	Grantee	Book	Page	Deed Type
9/1/2016	2,675,000	LAFRANCE STEPHEN JR/WENDY	MACE PROPERTIES LLC	2016	058236	WD (Warranty Deed)
7/10/2007	1,940,000	MAULDEN JERRY/ SUE A	LAFRANCE STEPHEN JR/WENDY	2007	054292	WADS ()
6/24/1993	699,000	ALSTADT LAURA G	MAULDEN JERRY/SUE A	93	41972	WD (Warranty Deed)

General Addendum

The Janet Jones Company / REALTORS®
7915 Cantrell Road / Little Rock, AR 72227
www.janetjones.com
501-224-7201



Copyright
2017
Arkansas
REALTORS®
Association

Page 1 of 2

Form Serial Number: 020941-900148-7789573

Regarding the Contract/Agreement (Form Serial Number 081699-500147-1375551),
dated (month) August (day) 19, (year) 2016, between Buyer/Lessee,
Stephen Lafrance Jr Wendy Lafrance, and Seller/Lessor,
_____, covering the
real property known as _____

(the "Property"), the undersigned Buyer/Lessee and Seller/Lessor, in consideration for the covenants, agreements and promises made below and other good and valuable consideration, receipt and sufficiency being acknowledged, agree as follows:

- ***Extend closing to September 1, 2017 .***
- ***Wendy will have until September 1, 2017 to approve the condo.***
- ***You will have until September 1, 2017 to file the Master Deed amendment.***
- ***Stephen and Wendy will pay you additional rent of \$24,000 (\$4,000/mo.), to be deposited up front; if closing occurs before September 1, 2017 the rent is prorated toward the purchase price. If Stephen and Wendy terminate for any reason, you keep any unused rent.***
- ***The Deposit is non-refundable once the Master Deed amendment is filed.***
- ***Stephen and Wendy can close early if they desire.***

General Addendum



Copyright
2017
Arkansas
REALTORS®
Association

Page 2 of 2

This General Addendum, upon its execution by both parties, incorporates by reference all provisions of the above-referenced Real Estate Contract/Agreement not expressly modified herein. This General Addendum may be executed in multiple counterparts each of which shall be regarded as an original hereof but all of which together shall constitute one in the same.

EXPIRATION: This General Addendum shall not be effective unless signed by Buyer/Lessee and Seller/Lessor on or before (month) February (day) 24, (year) 2017, at _____ (a.m.) (p.m.).

THIS IS A LEGALLY BINDING AGREEMENT WHEN SIGNED BY THE PARTIES BELOW. READ IT CAREFULLY. YOU MAY EMPLOY AN ATTORNEY TO DRAFT THIS FORM FOR YOU. IF YOU DO NOT UNDERSTAND THE EFFECT OF ANY PART, CONSULT YOUR ATTORNEY BEFORE SIGNING. REAL ESTATE AGENTS CANNOT GIVE YOU LEGAL ADVICE. THE PARTIES SIGNED BELOW WAIVE THEIR RIGHT TO HAVE AN ATTORNEY DRAFT THIS FORM AND HAVE AUTHORIZED THE REAL ESTATE AGENT(S) TO FILL IN THE BLANKS ON THIS FORM.

THIS FORM IS PRODUCED AND COPYRIGHTED BY THE ARKANSAS REALTORS® ASSOCIATION. THE SERIAL NUMBER BELOW IS A UNIQUE NUMBER NOT USED ON ANY OTHER FORM. THE SERIAL NUMBER BELOW SHOULD BE AN ORIGINAL PRINTING, NOT MACHINE COPIED, OTHERWISE THE FORM MAY HAVE BEEN ALTERED. DO NOT SIGN THIS FORM IF IT WAS PREPARED AFTER DECEMBER 31, 2017.

FORM SERIAL NUMBER: 020941-900148-7789573

The above General Addendum is executed on (month) February (day) 22, (year) 2017, at _____ (a.m.) (p.m.).

Janet Jones Company

Selling Firm

Signature: _____

Signature: Stephen Lafrance

Printed Name: _____

Printed Name: Stephen Lafrance Jr.

Principal or Executive Broker

Buyer/Lessee

Signature: Casey Jones

Signature: Wendy Lafrance

Printed Name: Casey Jones

Printed Name: Wendy Lafrance

Selling Agent

Buyer/Lessee

The above General Addendum is executed on (month) _____ (day) _____, (year) _____, at _____ (a.m.) (p.m.).

Listing Firm

Signature: _____

Signature: _____

Printed Name: _____

Printed Name: _____

Principal or Executive Broker

Seller/Lessor

Signature: _____

Signature: _____

Printed Name: _____

Printed Name: _____

Listing Agent

Seller/Lessor

Page 2 of 2

Certified This 22nd Day of September 2017

By *Rebecca D. Lynn*
Deputy Clerk



ARKANSAS STATE POLICE

Arkansas Criminal History Report

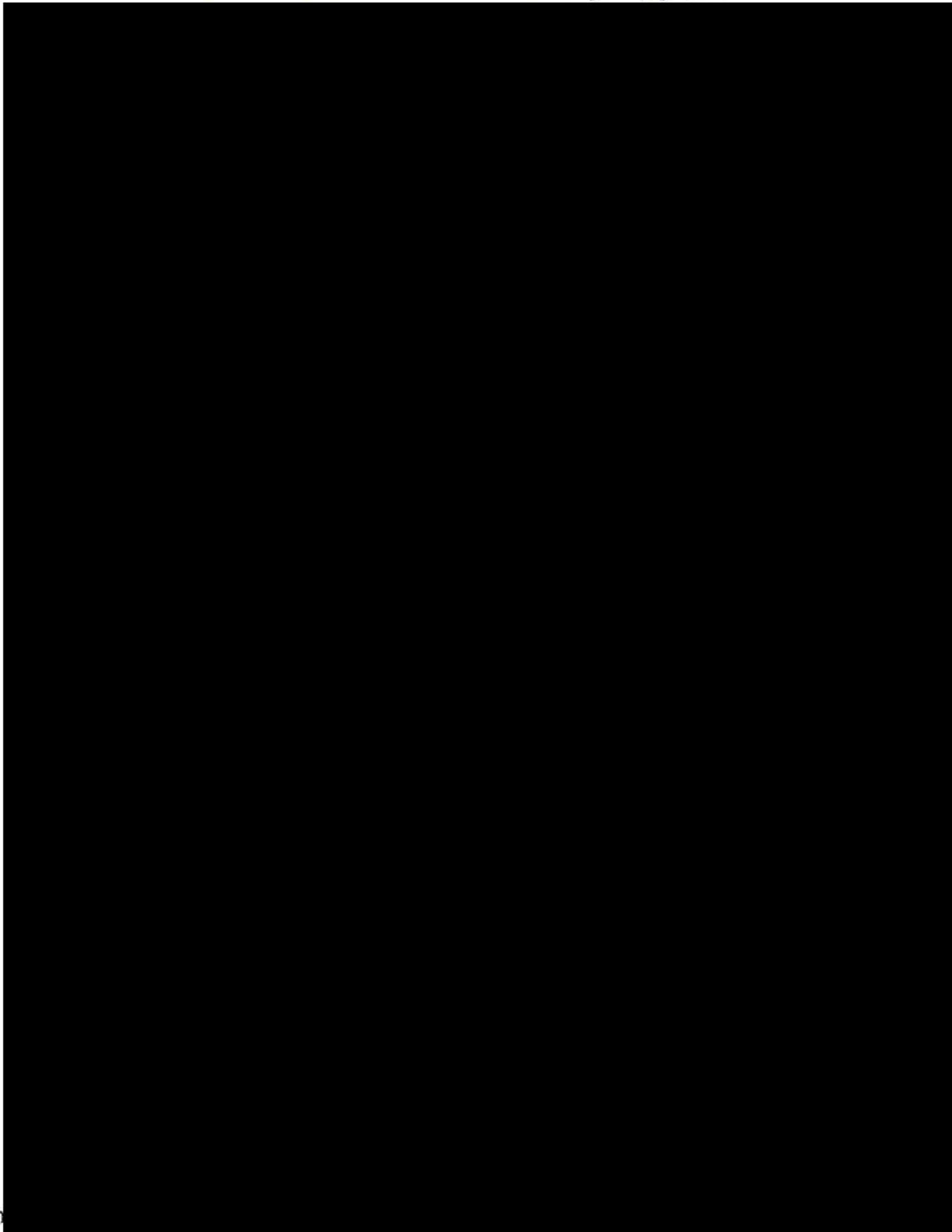

POLICE

APPLICATION FOR MEDICAL MARIJUANA CULTIVATION FACILITY

SECTION B. Applicant, Owner, Officer, or Board Member Disclosure Statement

Identify your affiliation with the proposed cultivation facility (Applicant, Owner, Officer, Board Member?) Include your percentage of equity ownership in the facility, if any.

Affiliation: Owner, Board Member

Percentage of Equity Ownership: 15.02%

Legal Name

*In addition to the information below, you are required to provide supporting documents to prove your legal name. See Section B, Appendix 1 for acceptable forms of proof.

Last Name Williams

First Name Susan

Middle Name Diane

Maiden Name (if applicable) _____

Alias(es) or former names Holley

SSN [REDACTED]

Date of Birth

*In addition to providing your date of birth, you are required to provide supporting documents to prove your date of birth. See Section B, Appendix 2 for acceptable forms of proof.

Date of Birth [REDACTED]

Contact Information

Mailing Address P.O. Box 55130

Little Rock, AR 72215

Phone Number (primary contact number) [REDACTED]

Email Address suswi59@yahoo.com

Residency

Are you an Arkansas resident? Yes

If you are not an Arkansas resident, please identify your primary place of residence.

Have you been an Arkansas resident for the past seven (7) years? Yes

If you answered "yes" to the question above, in addition to providing the information requested below, you are required to provide supporting documents to prove your residency for the past seven (7) years. See Section B, Appendix 3 for acceptable forms of proof.

Provide the address of your primary residence(s) for the past seven (7) years. Identify the dates (month and year) you resided at each listed location:

 **10/2006 - Present**

Tax Liability

Do you have any outstanding tax delinquencies owed to the State of Arkansas: No

If you answered "yes" to the previous question, please explain the nature of any delinquencies:

Other Financial Liabilities

Are you a party to any legal proceedings where damages, fines, or civil penalties may reasonably be expected to exceed \$500,000 above any insurance coverage available to cover the claim?

No

If the answer to the above question is “yes”, attach a statement describing the litigation, including the title and docket number of the litigation, the name and location of the court in which it is pending, the identity of all parties to the litigation, the general nature of the claims being made and the impact an unfavorable opinion may have on your ability to finance and operate the proposed cultivation facility. Any documents submitted in response to this requirement must be labeled with “Section B, Other Financial Liabilities”.

Regulatory History

Have you, or has any entity over which you exercised management or control, ever had any fines or other penalties over \$10,000 assessed by any regulatory agency? **Yes**

If the answer above is “yes”, attach a statement providing the details of such fines or penalties. Any documents submitted in response to this requirement must be labeled with “Section B, Regulatory History”.

Professional Licensure

Do you presently hold any type of professional license? **No**

If yes, identify the type of license and license number _____

Is the license in good standing? _____

Certification

I, Susan D. Williams, certify that the information provided in this form and its attachments is complete and accurate. I understand that any misstatement or concealment of fact may be grounds for refusal of application or revocation of license if later disclosed.

Signed this 2nd day of August, 2017.

Susan D. Williams
Signature of Applicant, Owner, Officer, or Board Member

Subscribed and sworn to before me this 2nd day of August, 2017.

Leticia Ditttrich
Notary Public

My Commission Expires: 12/19/2026



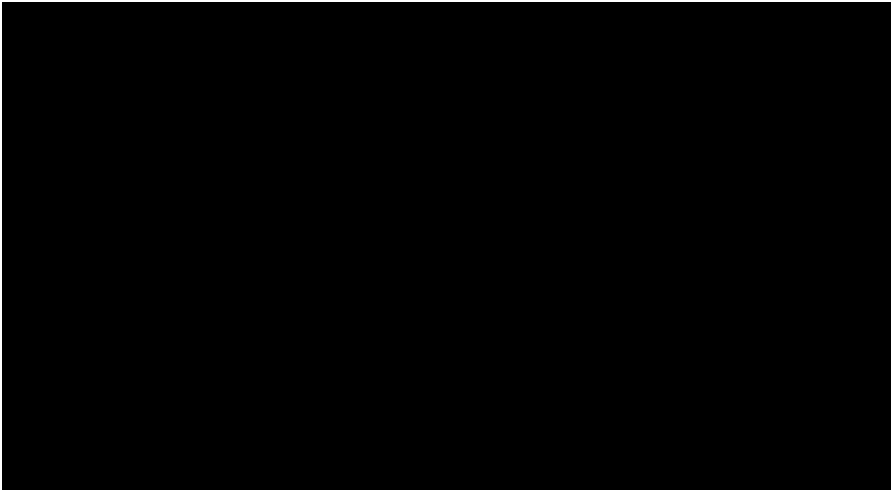
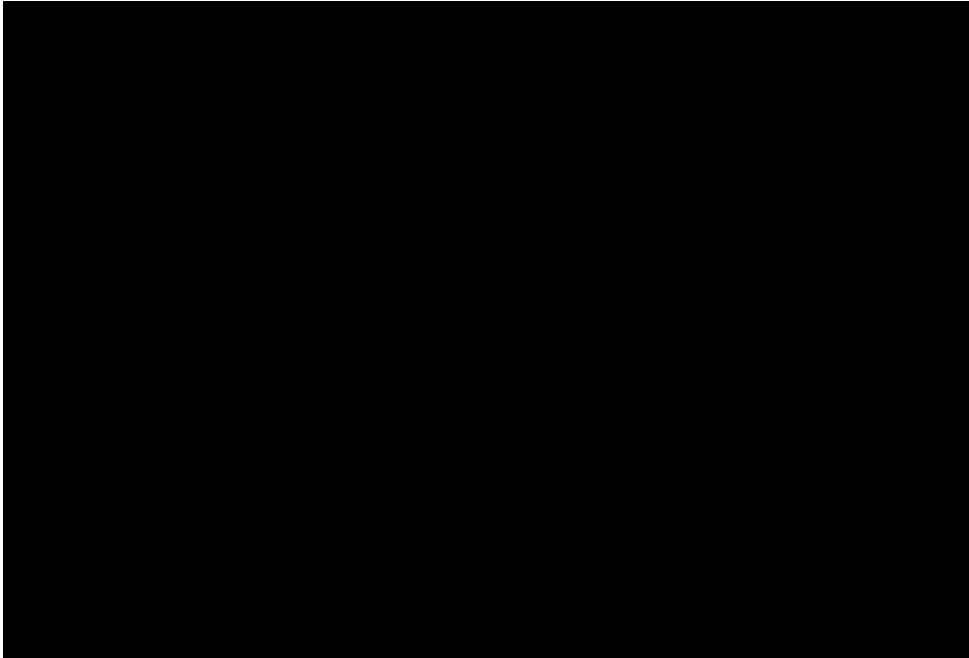

Parcel History Report

Created: 8/2/2017 9:37:10 AM

Basic Information	
Parcel Number:	53L0260145500
County Name:	Pulaski County
Owners Name:	WILLIAMS ALONZO D SR/SUSAN D
Billing Name:	WILLIAMS ALONZO D SR/SUSAN D
Billing Address:	PO BOX 55130
City, State, Zip:	LITTLE ROCK AR 72215

Assessment History

Year	Assessed Land	Assessed Building	Total Assessed	Taxable Value
2017	55,180	126,300	181,480	181,480
2013	34,000	139,220	173,220	173,220
2012	34,000	139,220	173,220	173,220
2012	34,000	198,440	232,440	196,284
2012	34,000	202,150	236,150	196,284
2012	34,000	206,360	240,360	196,284
2010	34,500	152,434	186,934	186,934
2010	34,500	152,434	186,934	186,934
2009	34,500	152,434	186,934	186,934
2008	34,500	152,434	186,934	186,934
2007	34,500	152,434	186,934	186,934
2006	34,500	152,434	186,934	186,934
2005	29,909	157,025	186,934	186,934
2004	30,000	156,934	186,934	186,934
2002	26,790	0	26,790	26,790

Ownership History

Date	Price	Grantor	Grantee	Book	Page	Deed Type
10/4/2006	0	ADC ANESTHESIA SERVICES PLC	WILLIAMS ALONZO D/SUSAN D	2006	083967	WADS ()
6/22/2002	0	PLAT G 417		2002	150897	UNKNOW ()
5/5/2000	0	ADAMETZ J R REV TRUST TO ADC A		00	030706	UNKNOW ()
4/1/1997	2	ADAMETZ TO SAME		97	23987	DEED (Deed)
3/1/1995	804,000			95	12048	DEED (Deed)
3/1/1994	159,000			94	22167	DEED (Deed)
5/5/1900	856,000	ADAMETZ TO ADC ANESTHESIA SERV		00	030707	DEED (Deed)

Individual Voting History Report

Williams, Susan Diane

[REDACTED]
[REDACTED]

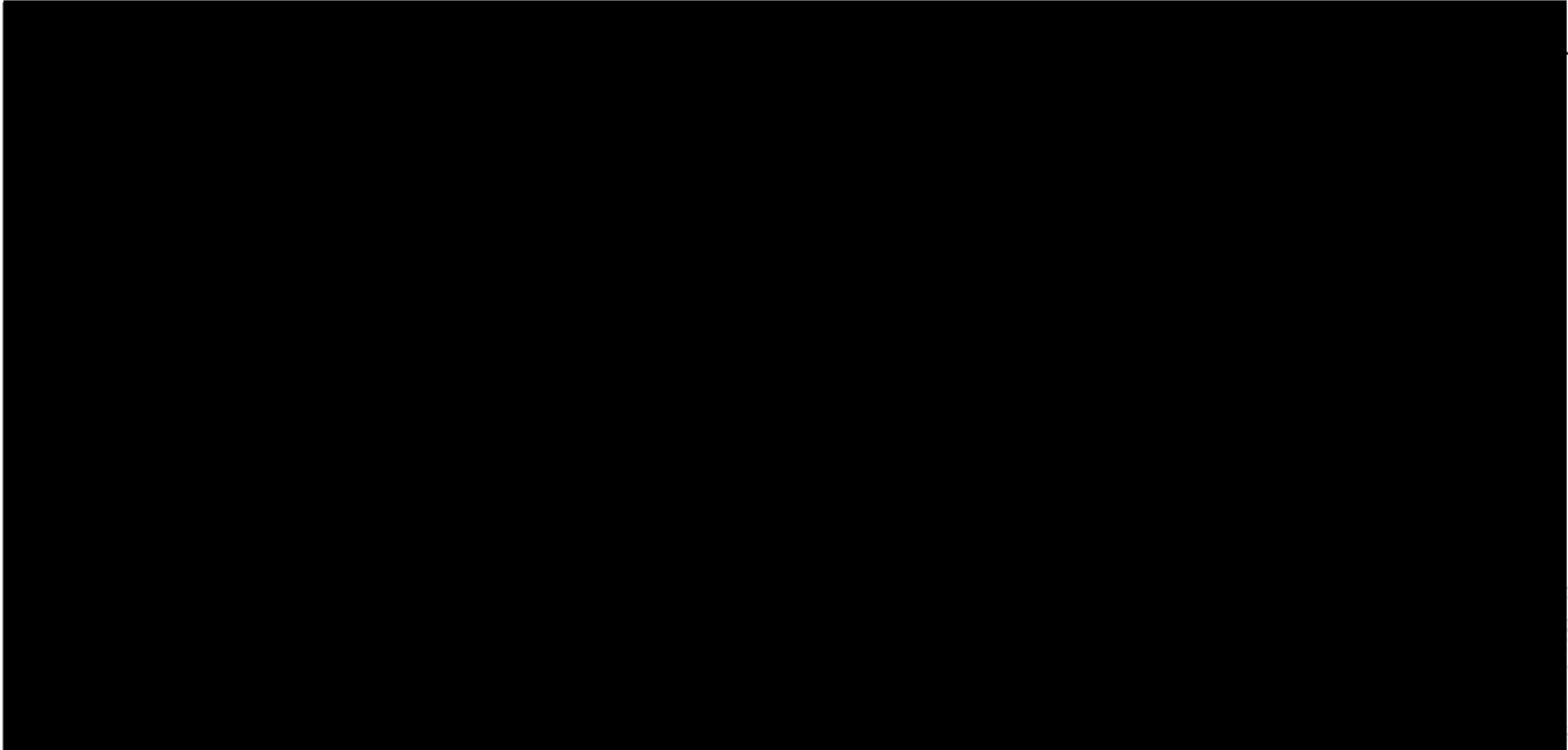

Continued from page _____ of _____

By _____ Deputy Clerk



Section B
Regulatory History



Section B - Criminal History Report

ARKANSAS STATE POLICE

Arkansas Criminal History Report

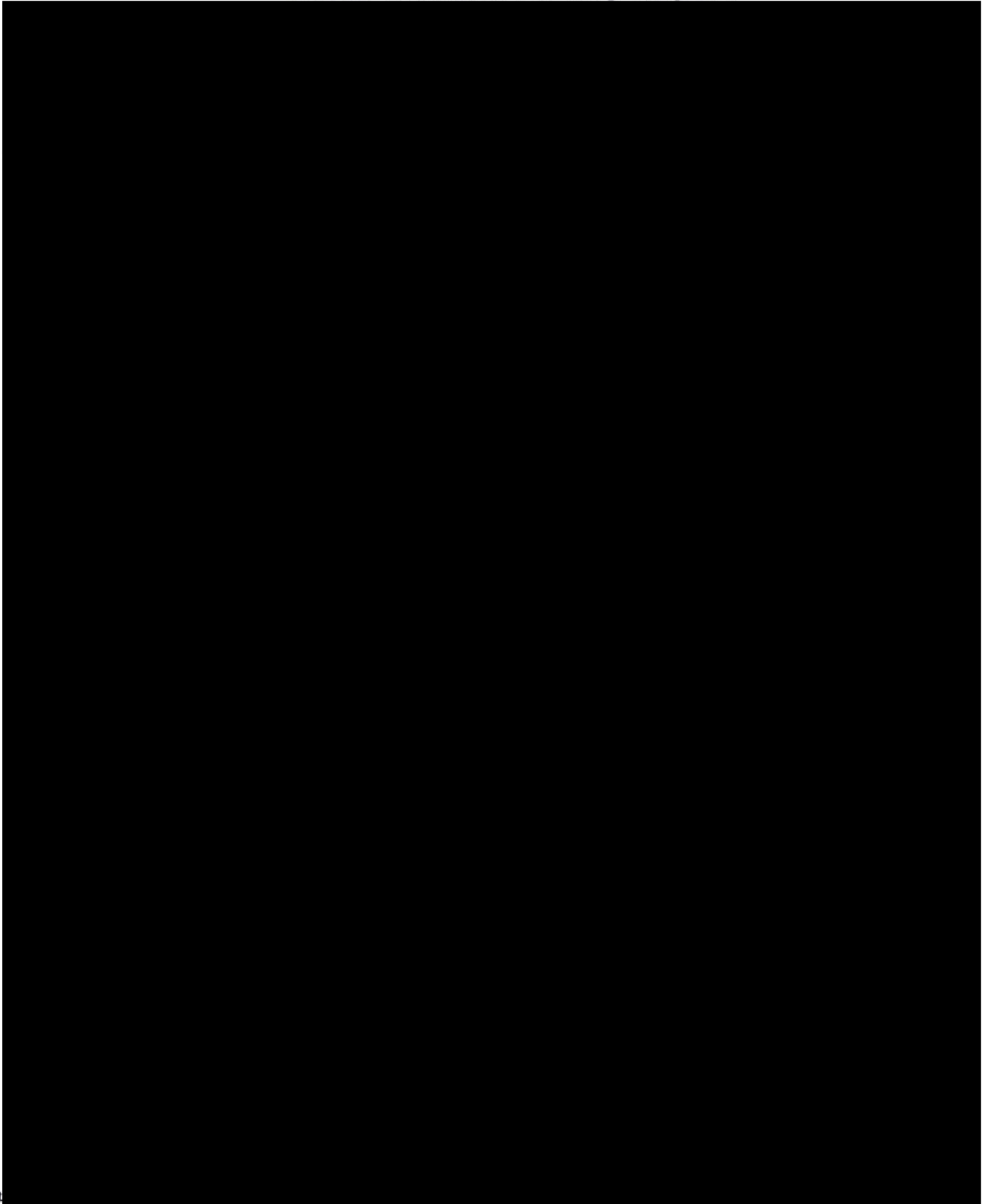

APPLICATION FOR MEDICAL MARIJUANA CULTIVATION FACILITY

SECTION B. Applicant, Owner, Officer, or Board Member Disclosure Statement

Identify your affiliation with the proposed cultivation facility (Applicant, Owner, Officer, Board Member?) Include your percentage of equity ownership in the facility, if any.

Affiliation: Owner,

Percentage of Equity Ownership: 10.07%

Legal Name

*In addition to the information below, you are required to provide supporting documents to prove your legal name. See Section B, Appendix 1 for acceptable forms of proof.

Last Name LaFrance

First Name Wendy

Middle Name Perdue

Maiden Name (if applicable) Wendolyn Carton Perdue

Alias(es) or former names Wendy Perdue

SSN [REDACTED]

Date of Birth

*In addition to providing your date of birth, you are required to provide supporting documents to prove your date of birth. See Section B, Appendix 2 for acceptable forms of proof.

Date of Birth [REDACTED]

Contact Information

Mailing Address P.O. Box 250530

Little Rock, AR 72225

Phone Number (primary contact number) [REDACTED]

Email Address wendy.lafrance@sbcglobal.net

Residency

Are you an Arkansas resident? Yes- entire life

If you are not an Arkansas resident, please identify your primary place of residence.

Have you been an Arkansas resident for the past seven (7) years? Yes

If you answered "yes" to the question above, in addition to providing the information requested below, you are required to provide supporting documents to prove your residency for the past seven (7) years. See Section B, Appendix 3 for acceptable forms of proof.

Provide the address of your primary residence(s) for the past seven (7) years. Identify the dates (month and year) you resided at each listed location:

 (Current)

Tax Liability

Do you have any outstanding tax delinquencies owed to the State of Arkansas: No

If you answered "yes" to the previous question, please explain the nature of any delinquencies:

Other Financial Liabilities

Are you a party to any legal proceedings where damages, fines, or civil penalties may reasonably be expected to exceed \$500,000 above any insurance coverage available to cover the claim?

No

If the answer to the above question is “yes”, attach a statement describing the litigation, including the title and docket number of the litigation, the name and location of the court in which it is pending, the identity of all parties to the litigation, the general nature of the claims being made and the impact an unfavorable opinion may have on your ability to finance and operate the proposed cultivation facility. Any documents submitted in response to this requirement must be labeled with “Section B, Other Financial Liabilities”.

Regulatory History

Have you, or has any entity over which you exercised management or control, ever had any fines or other penalties over \$10,000 assessed by any regulatory agency? **NO**

If the answer above is “yes”, attach a statement providing the details of such fines or penalties. Any documents submitted in response to this requirement must be labeled with “Section B, Regulatory History”.

Professional Licensure

Do you presently hold any type of professional license? **No**

If yes, identify the type of license and license number **N/A**

Is the license in good standing? **N/A**

Certification

I, Wendy LaFrance, certify that the information provided in this form and its attachments is complete and accurate. I understand that any misstatement or concealment of fact may be grounds for refusal of application or revocation of license if later disclosed.

Signed this 28th day of July, 2017.



Signature of Applicant, Owner, Officer, or Board Member

Subscribed and sworn to before me this 28th day of July,
2017.

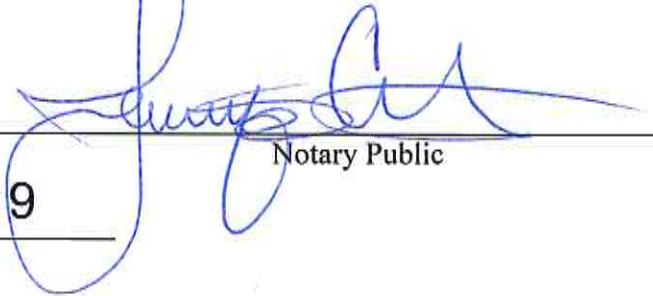

Notary Public

My Commission Expires: 04/06/2019

JENNIFER CATE
HOT SPRING COUNTY
NOTARY PUBLIC - ARKANSAS
My Commission Expires April 06, 2019
Commission No. 12370688

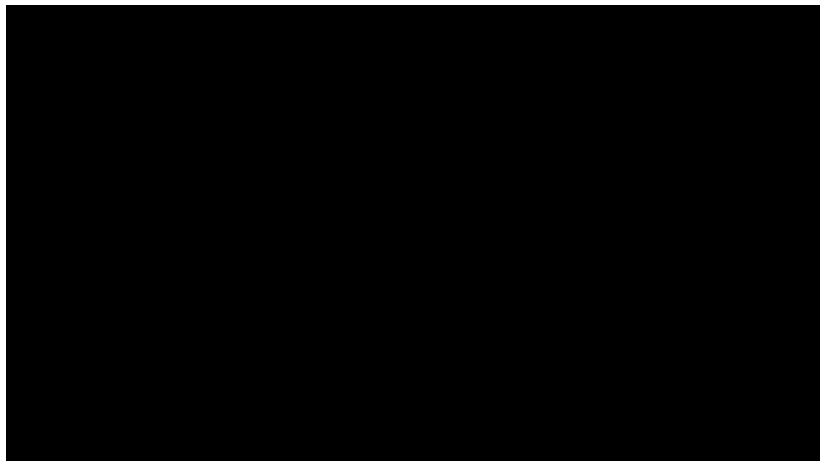
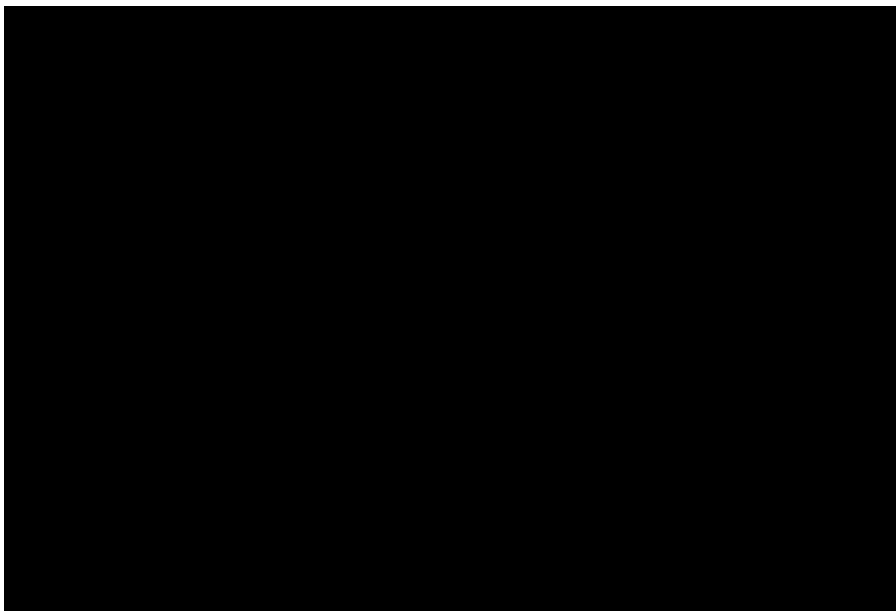

Parcel History Report

Created: 7/28/2017 4:43:47 PM

Basic Information	
Parcel Number:	33L0300002000
County Name:	Pulaski County
Owners Name:	MACE PROPERTIES LLC
Billing Name:	MACE PROPERTIES LLC
Billing Address:	[REDACTED]
City, State, Zip:	[REDACTED]

Assessment History

Year	Assessed Land	Assessed Building	Total Assessed	Taxable Value
2017	200,000	288,830	488,830	488,830
2017	120,000	263,740	383,740	383,740
2014	120,000	263,740	383,740	383,740
2013	120,000	263,740	383,740	383,740
2012	120,000	263,740	383,740	371,180
2012	84,000	216,100	300,100	300,100
2012	84,000	220,270	304,270	304,270
2010	60,000	293,500	353,500	353,500
2009	60,000	293,500	353,500	353,500
2008	60,000	275,764	335,764	335,764
2007	60,000	275,764	335,764	173,578
2006	60,000	261,976	321,976	173,579
2005	50,172	123,408	173,580	173,580
2004	53,800	130,780	184,580	173,580
2003	53,800	119,780	173,580	173,580
2002	39,516	0	39,516	39,516

Ownership History

Date	Price	Grantor	Grantee	Book	Page	Deed Type
9/1/2016	2,675,000	LAFRANCE STEPHEN JR/WENDY	MACE PROPERTIES LLC	2016	058236	WD (Warranty Deed)
7/10/2007	1,940,000	MAULDEN JERRY/ SUE A	LAFRANCE STEPHEN JR/WENDY	2007	054292	WADS ()
6/24/1993	699,000	ALSTADT LAURA G	MAULDEN JERRY/SUE A	93	41972	WD (Warranty Deed)

General Addendum

The Janet Jones Company / REALTORS®
7915 Cantrell Road / Little Rock, AR 72227
www.janetjones.com
501-224-7201



Copyright
2017
Arkansas
REALTORS®
Association

Page 1 of 2

Form Serial Number: 020941-900148-7789573

Regarding the Contract/Agreement(Form Serial Number 081699-500147-1375551),
dated (month) August (day) 19, (year) 2016, between Buyer/Lessee,
Stephen Lafrance Jr Wendy Lafrance, and Seller/Lessor,
_____, covering the
real property known as _____

(the "Property"), the undersigned Buyer/Lessee and Seller/Lessor, in consideration for the covenants, agreements and promises made below and other good and valuable consideration, receipt and sufficiency being acknowledged, agree as follows:

- ***Extend closing to September 1, 2017 .***
- ***Wendy will have until September 1, 2017 to approve the condo.***
- ***You will have until September 1, 2017to file the Master Deed amendment.***
- ***Stephen and Wendy will pay you additional rent of \$24,000 (\$4,000/mo.), to be deposited up front; if closing occurs before September 1, 2017 the rent is prorated toward the purchase price. If Stephen and Wendy terminate for any reason, you keep any unused rent.***
- ***The Deposit is non-refundable once the Master Deed amendment is filed.***
- ***Stephen and Wendy can close early if they desire.***

General Addendum



Copyright
2017
Arkansas
REALTORS®
Association

Page 2 of 2

This General Addendum, upon its execution by both parties, incorporates by reference all provisions of the above-referenced Real Estate Contract/Agreement not expressly modified herein. This General Addendum may be executed in multiple counterparts each of which shall be regarded as an original hereof but all of which together shall constitute one in the same.

EXPIRATION: This General Addendum shall not be effective unless signed by Buyer/Lessee and Seller/Lessor on or before (month) February (day) 24, (year) 2017, at _____ (a.m.) (p.m.).

THIS IS A LEGALLY BINDING AGREEMENT WHEN SIGNED BY THE PARTIES BELOW. READ IT CAREFULLY. YOU MAY EMPLOY AN ATTORNEY TO DRAFT THIS FORM FOR YOU. IF YOU DO NOT UNDERSTAND THE EFFECT OF ANY PART, CONSULT YOUR ATTORNEY BEFORE SIGNING. REAL ESTATE AGENTS CANNOT GIVE YOU LEGAL ADVICE. THE PARTIES SIGNED BELOW WAIVE THEIR RIGHT TO HAVE AN ATTORNEY DRAFT THIS FORM AND HAVE AUTHORIZED THE REAL ESTATE AGENT(S) TO FILL IN THE BLANKS ON THIS FORM.

THIS FORM IS PRODUCED AND COPYRIGHTED BY THE ARKANSAS REALTORS® ASSOCIATION. THE SERIAL NUMBER BELOW IS A UNIQUE NUMBER NOT USED ON ANY OTHER FORM. THE SERIAL NUMBER BELOW SHOULD BE AN ORIGINAL PRINTING, NOT MACHINE COPIED, OTHERWISE THE FORM MAY HAVE BEEN ALTERED. DO NOT SIGN THIS FORM IF IT WAS PREPARED AFTER DECEMBER 31, 2017.

FORM SERIAL NUMBER: 020941-900148-7789573

The above General Addendum is executed on (month) February (day) 22, (year) 2017, at _____ (a.m.) (p.m.).

Janet Jones Company

Selling Firm

Signature: _____

Signature: Stephen Lafrance

Printed Name: _____

Printed Name: Stephen Lafrance Jr.

Principal or Executive Broker

Buyer/Lessee

Signature: Casey Jones

Signature: Wendy Lafrance

Printed Name: Casey Jones

Printed Name: Wendy Lafrance

Selling Agent

Buyer/Lessee

The above General Addendum is executed on (month) _____ (day) _____, (year) _____, at _____ (a.m.) (p.m.).

Listing Firm

Signature: _____

Signature: _____

Printed Name: _____

Printed Name: _____

Principal or Executive Broker

Seller/Lessor

Signature: _____

Signature: _____

Printed Name: _____

Printed Name: _____

Listing Agent

Seller/Lessor

Page 2 of 2



Certified This 12th Day of September 2017

By Rebecca A. Lynn
Deputy Clerk

ARKANSAS STATE POLICE

Arkansas Criminal History Report

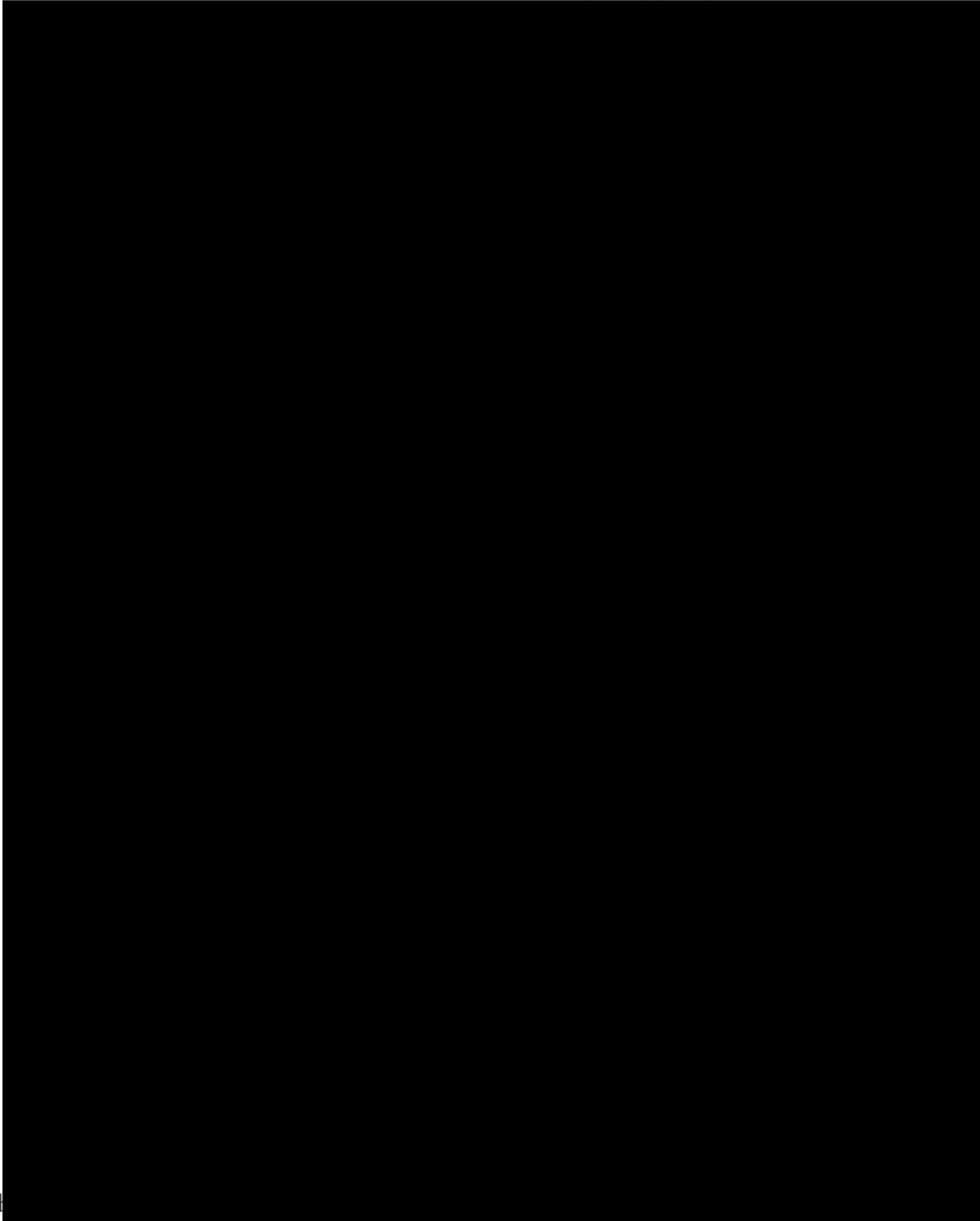

APPLICATION FOR MEDICAL MARIJUANA CULTIVATION FACILITY

SECTION B. Applicant, Owner, Officer, or Board Member Disclosure Statement

Identify your affiliation with the proposed cultivation facility (Applicant, Owner, Officer, Board Member?) Include your percentage of equity ownership in the facility, if any.

Affiliation: Cultivation Manager

Percentage of Equity Ownership: 0

Legal Name

*In addition to the information below, you are required to provide supporting documents to prove your legal name. See Section B, Appendix 1 for acceptable forms of proof.

Last Name Salini

First Name Andrew

Middle Name John

Maiden Name (if applicable) _____

Alias(es) or former names _____

SSN 

Date of Birth

*In addition to providing your date of birth, you are required to provide supporting documents to prove your date of birth. See Section B, Appendix 2 for acceptable forms of proof.

Date of Birth 

Contact Information

Mailing Address PO BOX 2968 Breckenridge CO, 80424

Phone Number (primary contact number) 

Email Address andrew@highcountryhealing.com

Residency

Are you an Arkansas resident? No

If you are not an Arkansas resident, please identify your primary place of residence.

965 North Ten Mile Drive Unit A2 Frisco, CO 80443

Have you been an Arkansas resident for the past seven (7) years? No

If you answered "yes" to the question above, in addition to providing the information requested below, you are required to provide supporting documents to prove your residency for the past seven (7) years. See Section B, Appendix 3 for acceptable forms of proof.

Provide the address of your primary residence(s) for the past seven (7) years. Identify the dates (month and year) you resided at each listed location:

[REDACTED]	4/17 - Present
[REDACTED]	11/16 - 4/17
[REDACTED]	4/16 - 11/16
[REDACTED]	1/15 - 4/16
[REDACTED]	11/14 - 11/15
[REDACTED]	7/10 - 11/14

Tax Liability

Do you have any outstanding tax delinquencies owed to the State of Arkansas: No

If you answered "yes" to the previous question, please explain the nature of any delinquencies:

Other Financial Liabilities

Are you a party to any legal proceedings where damages, fines, or civil penalties may reasonably be expected to exceed \$500,000 above any insurance coverage available to cover the claim?

No

If the answer to the above question is “yes”, attach a statement describing the litigation, including the title and docket number of the litigation, the name and location of the court in which it is pending, the identity of all parties to the litigation, the general nature of the claims being made and the impact an unfavorable opinion may have on your ability to finance and operate the proposed cultivation facility. Any documents submitted in response to this requirement must be labeled with “Section B, Other Financial Liabilities”.

Regulatory History

Have you, or has any entity over which you exercised management or control, ever had any fines or other penalties over \$10,000 assessed by any regulatory agency? **No**

If the answer above is “yes”, attach a statement providing the details of such fines or penalties. Any documents submitted in response to this requirement must be labeled with “Section B, Regulatory History”.

Professional Licensure

Do you presently hold any type of professional license? **Yes**

If yes, identify the type of license and license number CO MED Occupational Support Lic #: M23303

Is the license in good standing? **Yes**

Certification

I, ANDREW SALINI, certify that the information provided in this form and its attachments is complete and accurate. I understand that any misstatement or concealment of fact may be grounds for refusal of application or revocation of license if later disclosed.

Signed this 29th day of AUGUST, 2017.

Andrew Salini
Signature of Applicant, Owner, Officer, or Board Member

Subscribed and sworn to before me this 29 day of August, 2017.

[Signature]

Notary Public

My Commission Expires: 4/07/2020

NETRA RAJ NEUPANE
NOTARY PUBLIC
STATE OF COLORADO
NOTARY ID 20164013421
MY COMMISSION EXPIRES 04/07/2020

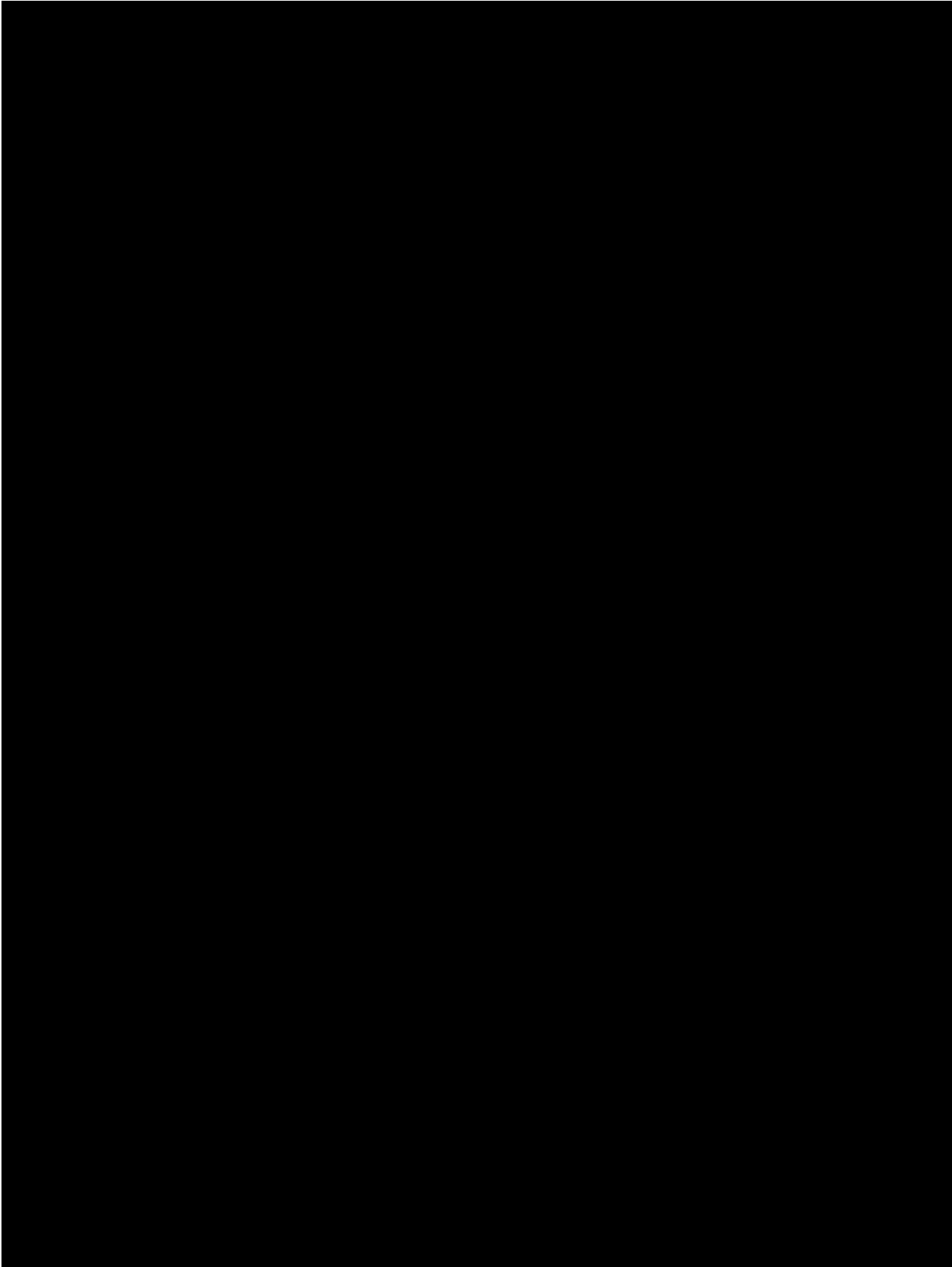

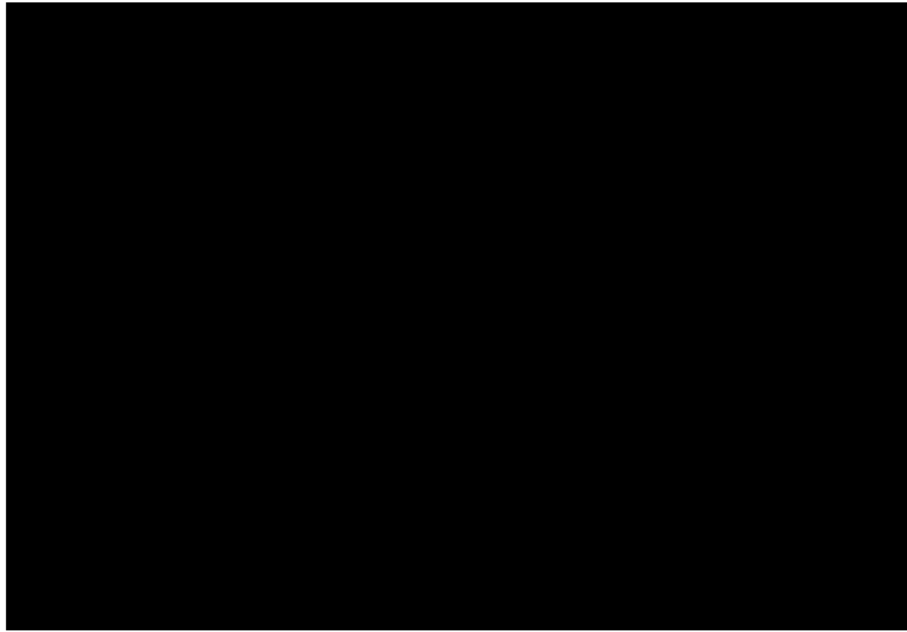

MMC-OPC-MIP
EMPLOYEE



ANDREW

Lic #: M23303

Exp: 11/20/18



S
U
P
P
O
R
T

ARKANSAS STATE POLICE

Arkansas Criminal History Report

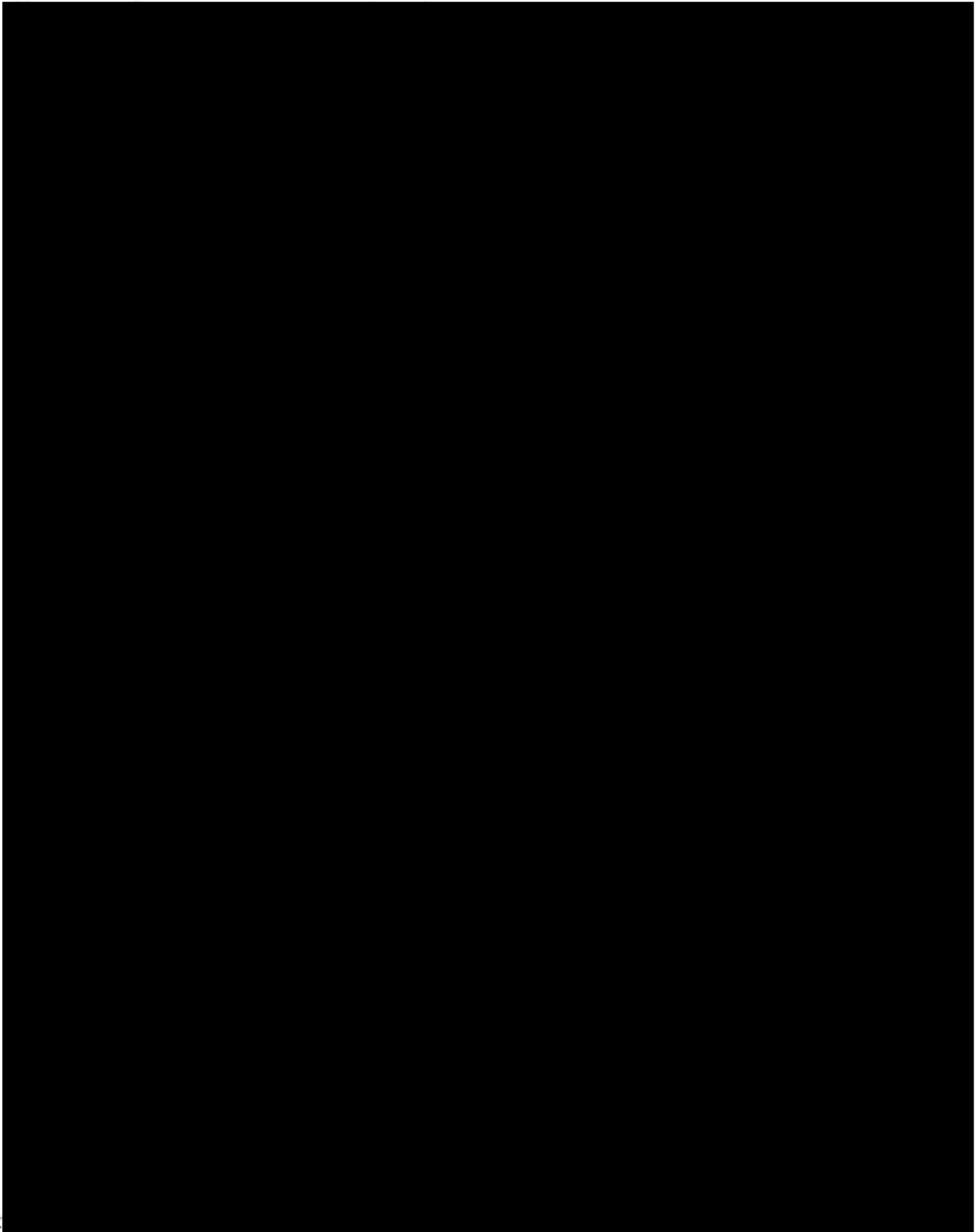

APPLICATION FOR MEDICAL MARIJUANA CULTIVATION FACILITY

SECTION B. Applicant, Owner, Officer, or Board Member Disclosure Statement

Identify your affiliation with the proposed cultivation facility (Applicant, Owner, Officer, Board Member?) Include your percentage of equity ownership in the facility, if any.

Affiliation: Third Party Compliance Officer

Percentage of Equity Ownership: 0%

Legal Name

*In addition to the information below, you are required to provide supporting documents to prove your legal name. See Section B, Appendix 1 for acceptable forms of proof.

Last Name Cummins III

First Name Harry

Middle Name Earnest

Maiden Name (if applicable) _____

Alias(es) or former names Bud Cummins

SSN [REDACTED]

Date of Birth

*In addition to providing your date of birth, you are required to provide supporting documents to prove your date of birth. See Section B, Appendix 2 for acceptable forms of proof.

Date of Birth August 6th, 1959

Contact Information

Mailing Address [REDACTED]

[REDACTED]

Phone Number (primary contact number) [REDACTED]

Email Address bud@budcumminslaw.com

Residency

Are you an Arkansas resident? Yes

If you are not an Arkansas resident, please identify your primary place of residence.

Have you been an Arkansas resident for the past seven (7) years? Yes

If you answered "yes" to the question above, in addition to providing the information requested below, you are required to provide supporting documents to prove your residency for the past seven (7) years. See Section B, Appendix 3 for acceptable forms of proof.

Provide the address of your primary residence(s) for the past seven (7) years. Identify the dates (month and year) you resided at each listed location:

 2002-Present

Tax Liability

Do you have any outstanding tax delinquencies owed to the State of Arkansas: No

If you answered "yes" to the previous question, please explain the nature of any delinquencies:

Other Financial Liabilities

Are you a party to any legal proceedings where damages, fines, or civil penalties may reasonably be expected to exceed \$500,000 above any insurance coverage available to cover the claim?

No

If the answer to the above question is “yes”, attach a statement describing the litigation, including the title and docket number of the litigation, the name and location of the court in which it is pending, the identity of all parties to the litigation, the general nature of the claims being made and the impact an unfavorable opinion may have on your ability to finance and operate the proposed cultivation facility. Any documents submitted in response to this requirement must be labeled with “Section B, Other Financial Liabilities”.

Regulatory History

Have you, or has any entity over which you exercised management or control, ever had any fines or other penalties over \$10,000 assessed by any regulatory agency? **No**

If the answer above is “yes”, attach a statement providing the details of such fines or penalties. Any documents submitted in response to this requirement must be labeled with “Section B, Regulatory History”.

Professional Licensure

Do you presently hold any type of professional license? **Yes**

If yes, identify the type of license and license number **Attorney AR 89010**

Is the license in good standing? **Yes**

Certification

I, HARRY E. CUMMINS III, certify that the information provided in this form and its attachments is complete and accurate. I understand that any misstatement or concealment of fact may be grounds for refusal of application or revocation of license if later disclosed.

Signed this 13th day of August, 2017.

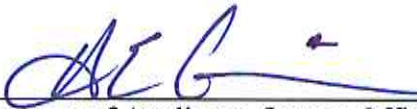

Signature of Applicant, Owner, Officer, or Board Member

Subscribed and sworn to before me this 13th day of August, 2017.

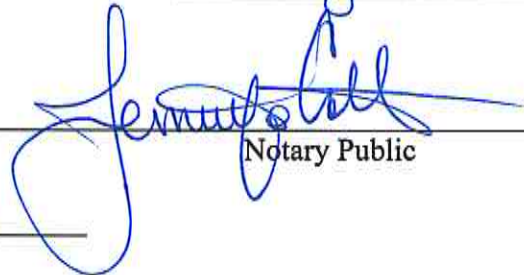

Notary Public

My Commission Expires: 4/6/2019

JENNIFER CATE
HOT SPRING COUNTY
NOTARY PUBLIC - ARKANSAS
My Commission Expires April 06, 2019
Commission No. 12370585

ARKANSAS DEPARTMENT OF HEALTH
Division of Vital Records
REPORT OF MARRIAGE

98-029255

TYPE OR PRINT ONLY

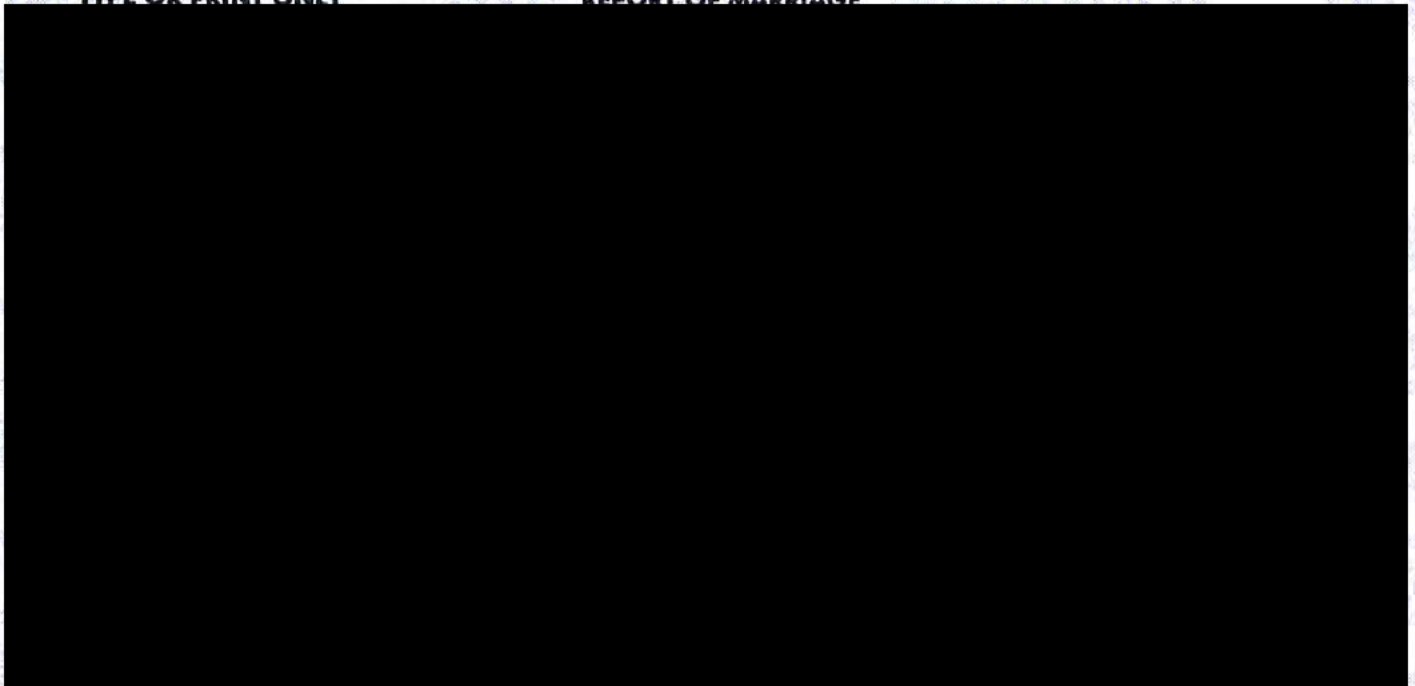

THIS IS TO CERTIFY THAT THE ABOVE IS A TRUE AND CORRECT COPY OF THE CERTIFICATE ON FILE IN THE ARKANSAS DEPARTMENT OF HEALTH.

AUG 23 2017

Shirley Louie

Shirley Louie
State Registrar

5803404

5803404



WARNING: A REPRODUCTION OF THIS DOCUMENT RENDERS IT VOID AND INVALID. DO NOT ACCEPT UNLESS EMBOSSED SEAL OF THE ARKANSAS DEPARTMENT OF HEALTH IS PRESENT. IT IS ILLEGAL TO ALTER OR COUNTERFEIT THIS DOCUMENT.

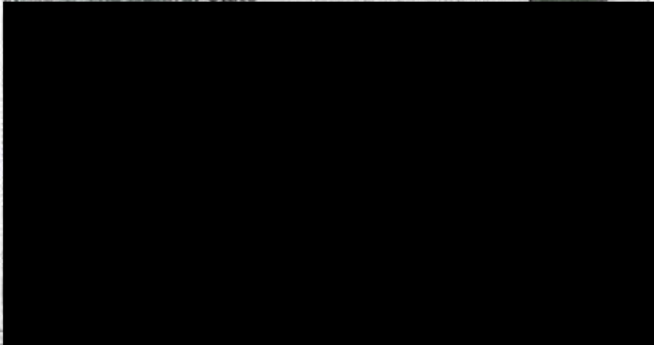

We the People

*Of the United States,
in Order to form a more perfect Union,
establish Justice, insure domestic Tranquility,
provide for the common defence,
promote the general Welfare, and secure
the Blessings of Liberty to ourselves and
our Posterity, do ordain and establish this
Constitution for the United States of America.*



[Handwritten Signature]

SIGNATURE OF BEARER / SIGNATURE DU TITULAIRE / FIRMA DEL TITULAR

3

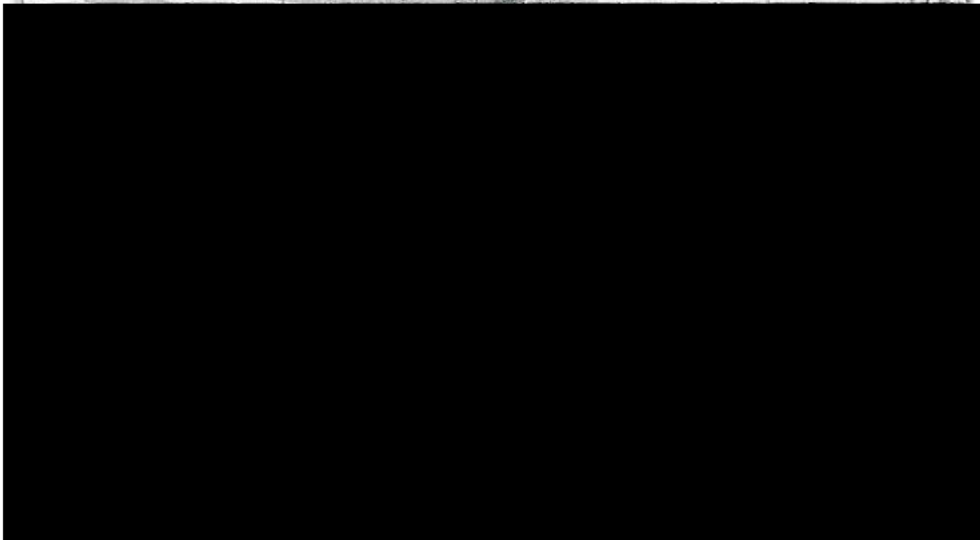

Parcel History Report

Created: 8/16/2017 12:10:36 AM

Basic Information	
Parcel Number:	33L0290002400
County Name:	Pulaski County
Owners Name:	CUMMINS H E III & JODY
Billing Name:	CUMMINS H E III & JODY
Billing Address:	██████████
City, State, Zip:	██████████

Assessment History

Year	Assessed Land	Assessed Building	Total Assessed	Taxable Value
2017	55,200	59,980	115,180	87,048
2017	55,200	42,600	97,800	87,048
2016	55,200	42,600	97,800	82,908
2015	55,200	42,600	97,800	79,588
2014	55,200	42,600	97,800	76,268
2013	55,200	42,600	97,800	72,948
2012	55,200	42,600	97,800	69,628
2012	38,000	69,060	107,060	69,628
2011	16,600	127,080	143,680	66,308
2010	16,600	127,080	143,680	63,298
2009	16,600	127,080	143,680	60,288
2008	16,600	118,459	135,059	57,417
2007	16,600	118,459	135,059	54,921
2006	16,600	118,459	135,059	52,425
2005	14,979	34,951	49,930	49,930
2004	15,000	34,930	49,930	49,930
2003	15,000	34,930	49,930	49,930
2002	13,708	0	13,708	13,708

Ownership History

Date	Price	Grantor	Grantee	Book	Page	Deed Type
3/1/2002	471,000	ORSINI to CUMMINS H E III & JO		02	120699	WADS ()
7/1/1995	267,000			95	42140	DEED (Deed)
11/1/1989	119,000			89	61796	DEED (Deed)
10/1/1985	185,000			85	55878	DEED (Deed)

Section B-Arkansas Criminal History Report ARKANSAS STATE POLICE

Arkansas Criminal History Report

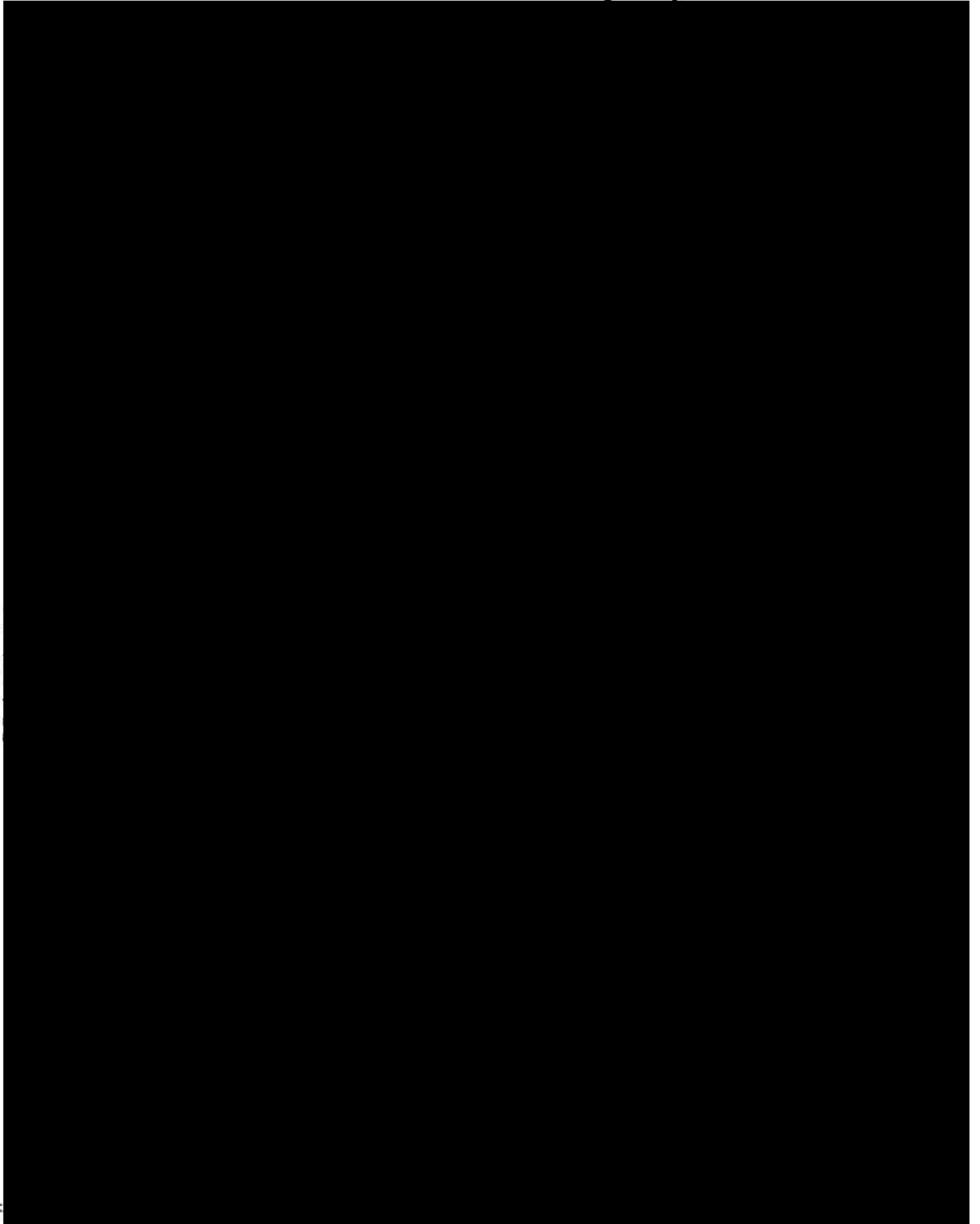

APPLICATION FOR MEDICAL MARIJUANA CULTIVATION FACILITY

SECTION B. Applicant, Owner, Officer, or Board Member Disclosure Statement

Identify your affiliation with the proposed cultivation facility (Applicant, Owner, Officer, Board Member?) Include your percentage of equity ownership in the facility, if any.

Affiliation: Director of Agriculture and Genetics

Percentage of Equity Ownership: 0%

Legal Name

*In addition to the information below, you are required to provide supporting documents to prove your legal name. See Section B, Appendix 1 for acceptable forms of proof.

Last Name Groves

First Name Frank

Middle Name Edward

Maiden Name (if applicable) _____

Alias(es) or former names _____

SSN  _____

Date of Birth

*In addition to providing your date of birth, you are required to provide supporting documents to prove your date of birth. See Section B, Appendix 2 for acceptable forms of proof.

Date of Birth  _____

Contact Information

Mailing Address  _____

 _____

Phone Number (primary contact number)  _____

Email Address groves88@yahoo.com

Residency

Are you an Arkansas resident? Yes

If you are not an Arkansas resident, please identify your primary place of residence.

Have you been an Arkansas resident for the past seven (7) years? No

If you answered “yes” to the question above, in addition to providing the information requested below, you are required to provide supporting documents to prove your residency for the past seven (7) years. See Section B, Appendix 3 for acceptable forms of proof.

Provide the address of your primary residence(s) for the past seven (7) years. Identify the dates (month and year) you resided at each listed location:

[REDACTED]	(5-1-16 to Present)
[REDACTED]	(8-1-15 to 4-30-16)
[REDACTED]	(10-1-14 to 7-31-15)
[REDACTED]	(2-1-04 to 9-30-14)

Tax Liability

Do you have any outstanding tax delinquencies owed to the State of Arkansas: No

If you answered “yes” to the previous question, please explain the nature of any delinquencies:

Other Financial Liabilities

Are you a party to any legal proceedings where damages, fines, or civil penalties may reasonably be expected to exceed \$500,000 above any insurance coverage available to cover the claim?

No

If the answer to the above question is “yes”, attach a statement describing the litigation, including the title and docket number of the litigation, the name and location of the court in which it is pending, the identity of all parties to the litigation, the general nature of the claims being made and the impact an unfavorable opinion may have on your ability to finance and operate the proposed cultivation facility. Any documents submitted in response to this requirement must be labeled with “Section B, Other Financial Liabilities”.

Regulatory History

Have you, or has any entity over which you exercised management or control, ever had any fines or other penalties over \$10,000 assessed by any regulatory agency? **No**_____.

If the answer above is “yes”, attach a statement providing the details of such fines or penalties. Any documents submitted in response to this requirement must be labeled with “Section B, Regulatory History”.

Professional Licensure

Do you presently hold any type of professional license? **No**_____

If yes, identify the type of license and license number_____

Is the license in good standing? _____

Certification

I, FRANK E GROVES, certify that the information provided in this form and its attachments is complete and accurate. I understand that any misstatement or concealment of fact may be grounds for refusal of application or revocation of license if later disclosed.

Signed this 17 day of AUGUST 2017.



Signature of Applicant, Owner, Officer, or Board Member

Subscribed and sworn to before me this 17th day of August, 2017.

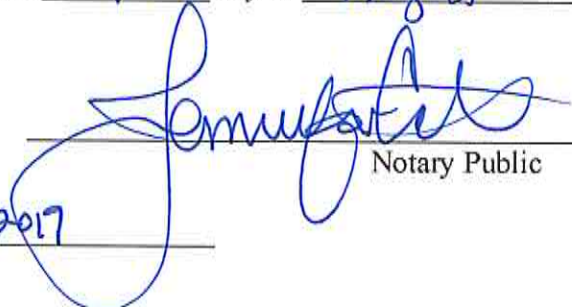

Notary Public

My Commission Expires: 4/6/2017

JENNIFER CATE
HOT SPRING COUNTY
NOTARY PUBLIC - ARKANSAS
My Commission Expires April 06, 2019
Commission No. 12370686

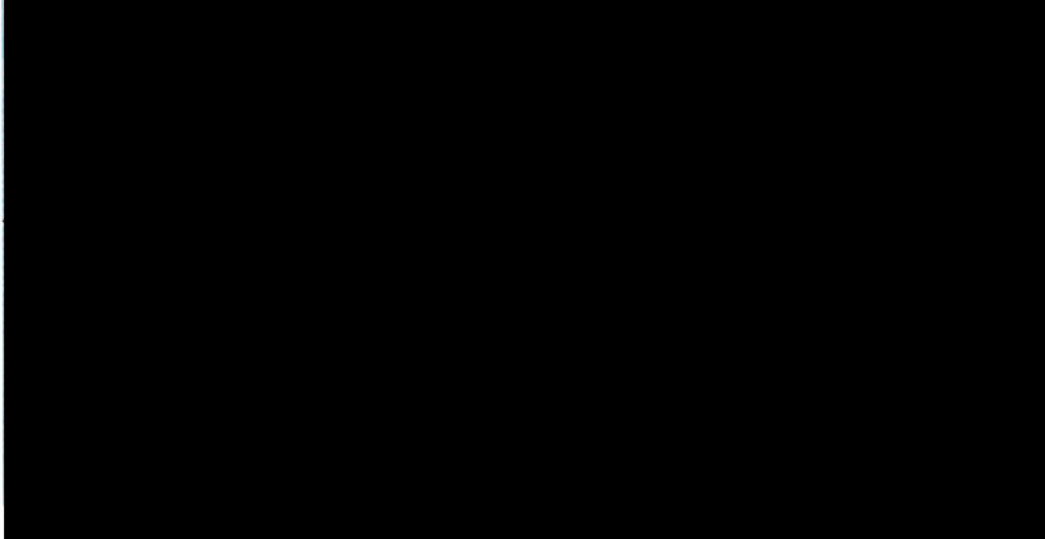
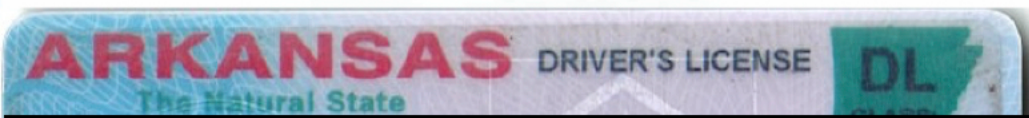
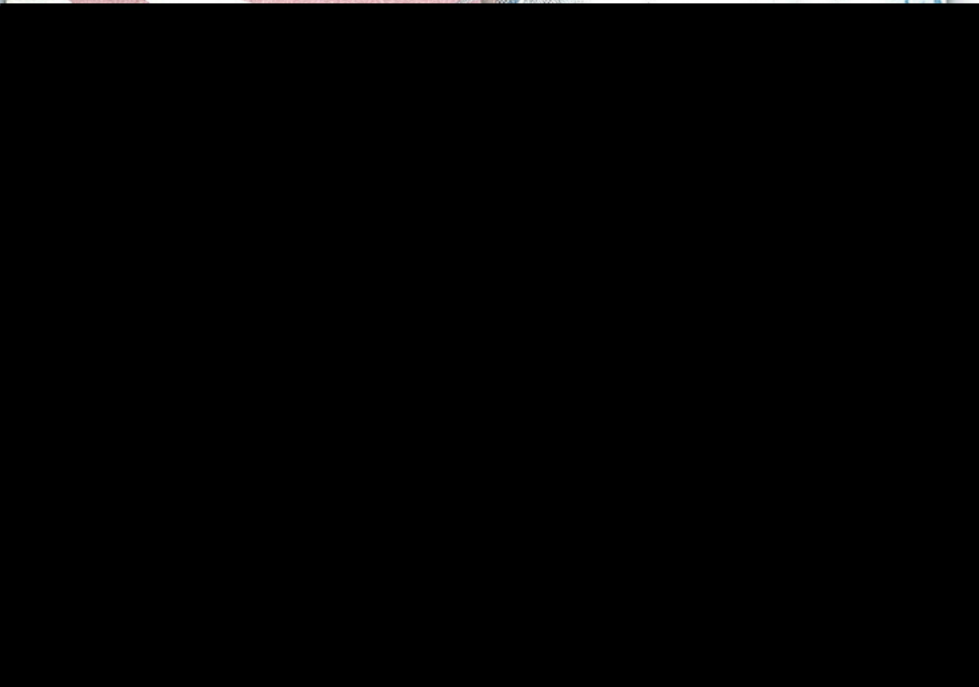

**Section B-Criminal History
Report**

ARKANSAS STATE POLICE

Arkansas Criminal History Report

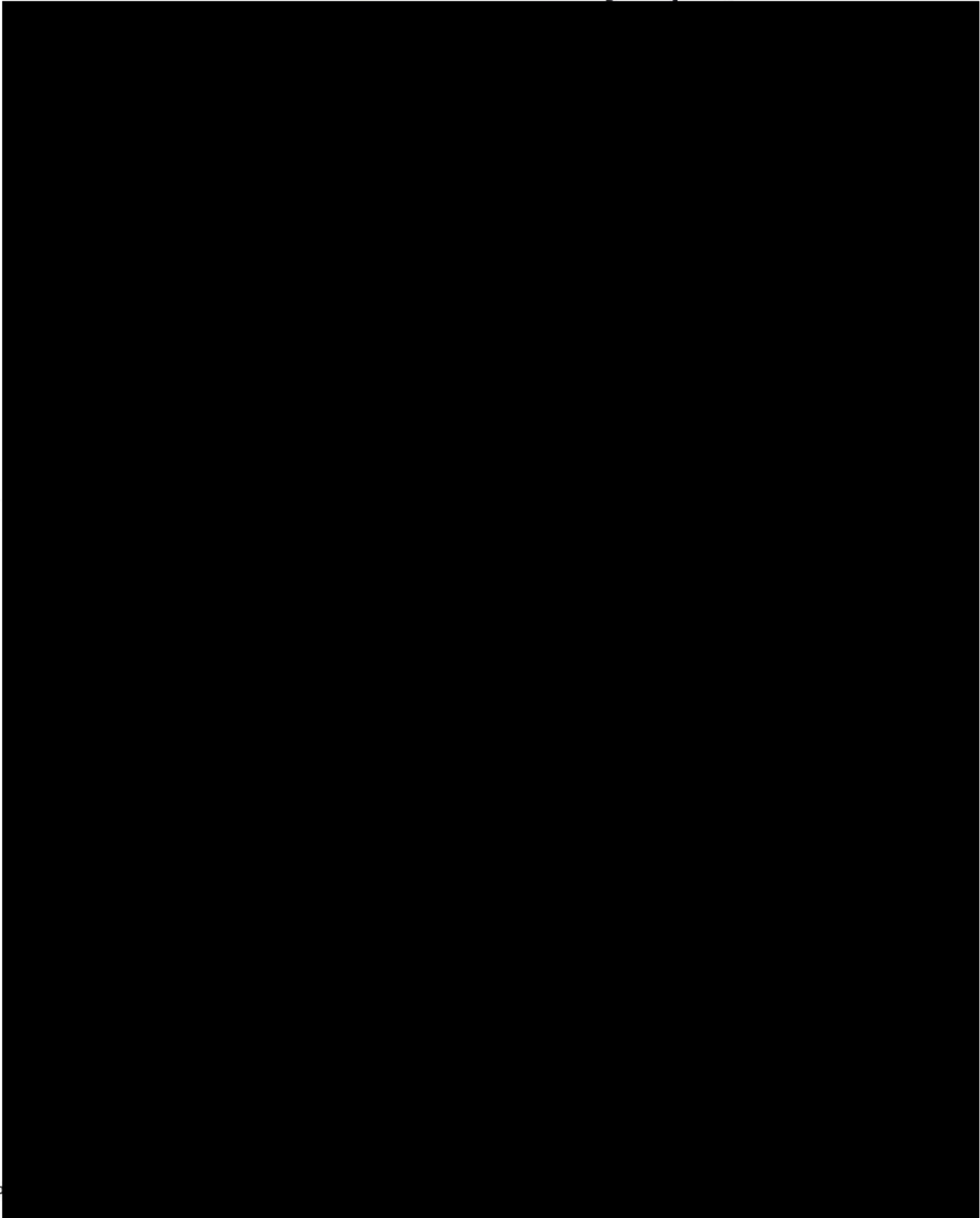

Email Address joshlriley@icloud.com

Residency

Are you an Arkansas resident? No

If you are not an Arkansas resident, please identify your primary place of residence.

[REDACTED]

Have you been an Arkansas resident for the past seven (7) years? No

If you answered “yes” to the question above, in addition to providing the information requested below, you are required to provide supporting documents to prove your residency for the past seven (7) years. See Section B, Appendix 3 for acceptable forms of proof.

Provide the address of your primary residence(s) for the past seven (7) years. Identify the dates (month and year) you resided at each listed location:

[REDACTED] 7/1/2014 - Present

[REDACTED] 1/1/2010 - 7/1/2014

Tax Liability

Do you have any outstanding tax delinquencies owed to the State of Arkansas: No

If you answered “yes” to the previous question, please explain the nature of any delinquencies:

Other Financial Liabilities

Are you a party to any legal proceedings where damages, fines, or civil penalties may reasonably be expected to exceed \$500,000 above any insurance coverage available to cover the claim?

No

If the answer to the above question is “yes”, attach a statement describing the litigation, including the title and docket number of the litigation, the name and location of the court in which it is pending, the identity of all parties to the litigation, the general nature of the claims being made and the impact an unfavorable opinion may have on your ability to finance and operate the proposed cultivation facility. Any documents submitted in response to this requirement must be labeled with “Section B, Other Financial Liabilities”.

Regulatory History

Have you, or has any entity over which you exercised management or control, ever had any fines or other penalties over \$10,000 assessed by any regulatory agency? No.

If the answer above is “yes”, attach a statement providing the details of such fines or penalties. Any documents submitted in response to this requirement must be labeled with “Section B, Regulatory History”.

Professional Licensure

Do you presently hold any type of professional license? Colorado Medical Enforcement Division

If yes, identify the type of license and license number M31279

Is the license in good standing? Yes

Certification

I, Joshua Risley, certify that the information provided in this form and its attachments is complete and accurate. I understand that any misstatement or concealment of fact may be grounds for refusal of application or revocation of license if later disclosed.

Signed this 1st day of September, 2017.

Joshua Risley

Signature of Applicant, Owner, Officer, or Board Member

Subscribed and sworn to before me this 1st day of September, 2017.

Janet L. Broadway
Notary Public

My Commission Expires: 9-1-21



We the People

*Of the United States,
in Order to form a more perfect Union,
establish Justice, insure domestic Tranquility,
provide for the common defence,
promote the general Welfare, and secure
the Blessings of Liberty to ourselves and
our Posterity, do ordain and establish this
Constitution for the United States of America.*



A handwritten signature in black ink, written over a horizontal line.

SIGNATURE OF BEARER / SIGNATURE DU TITULAIRE / FIRMA DEL TITULAR

3

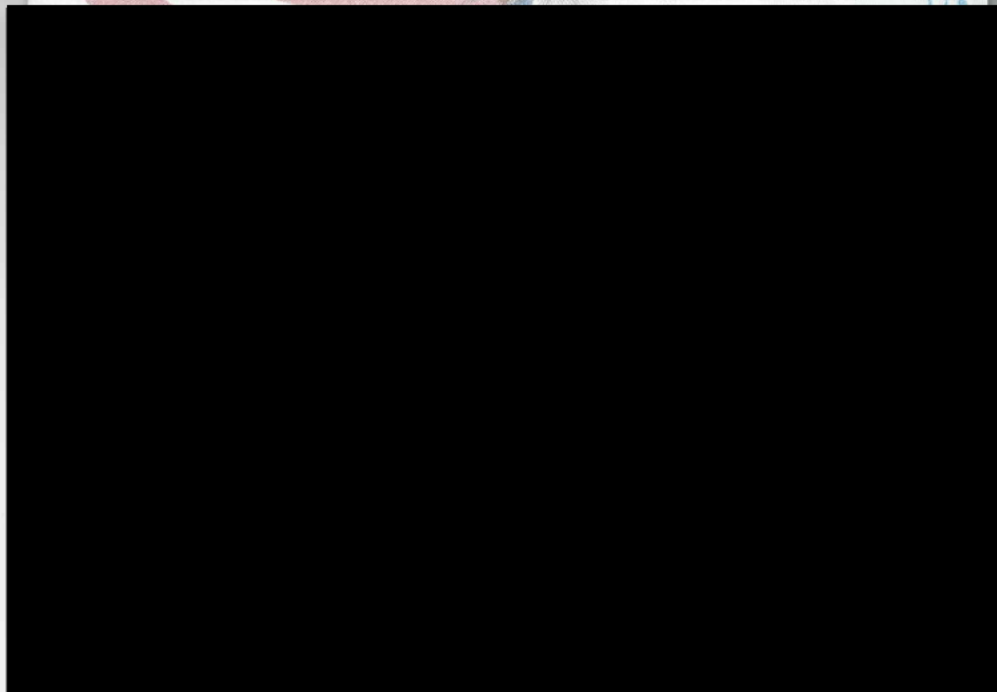

Section B - Professional License

ARKANSAS STATE POLICE

Arkansas Criminal History Report

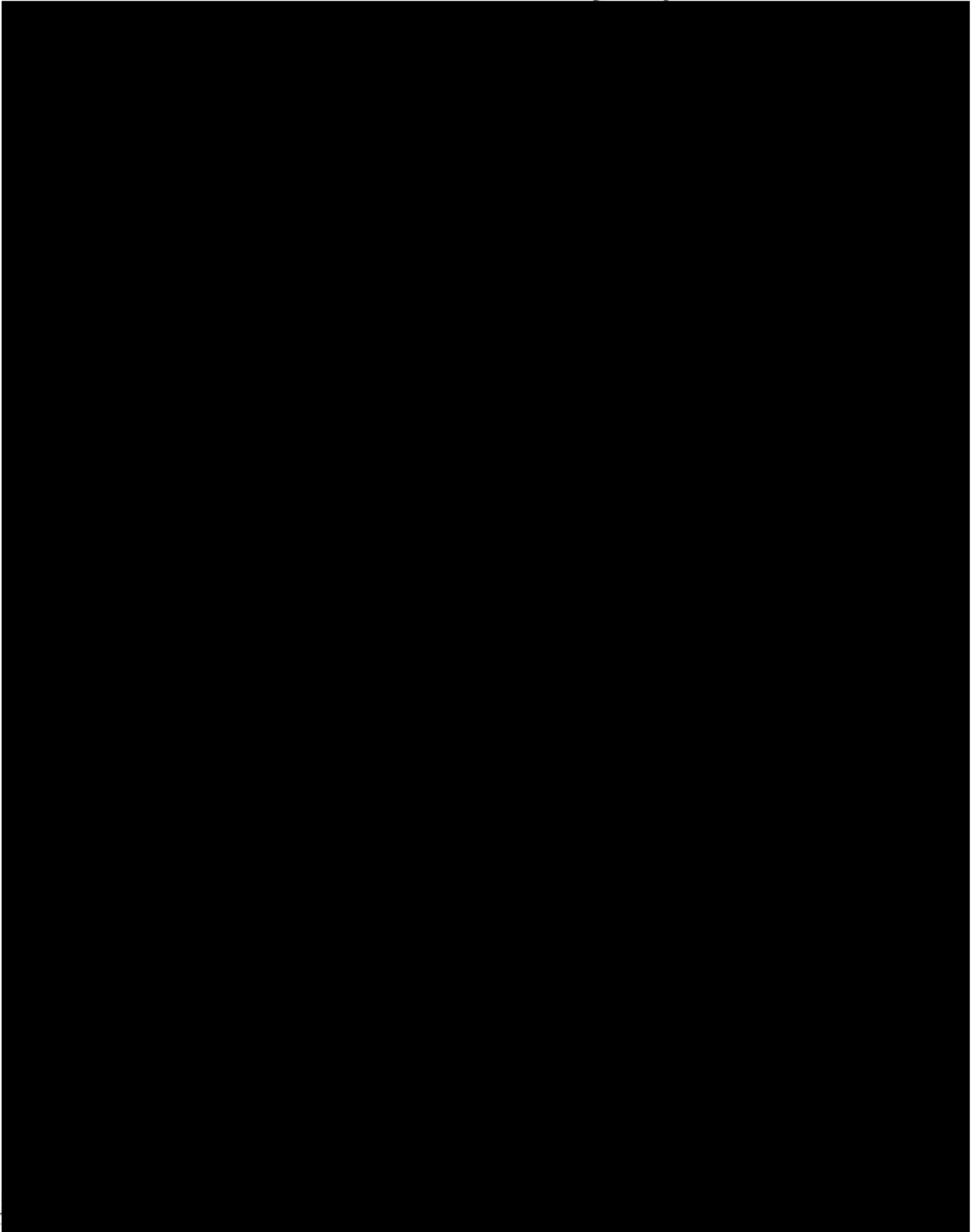

APPLICATION FOR MEDICAL MARIJUANA CULTIVATION FACILITY

SECTION B. Applicant, Owner, Officer, or Board Member Disclosure Statement

Identify your affiliation with the proposed cultivation facility (Applicant, Owner, Officer, Board Member?) Include your percentage of equity ownership in the facility, if any.

Affiliation: Director of Security

Percentage of Equity Ownership: 0

Legal Name

*In addition to the information below, you are required to provide supporting documents to prove your legal name. See Section B, Appendix 1 for acceptable forms of proof.

Last Name Huey

First Name Lance

Middle Name Tyler

Maiden Name (if applicable) _____

Alias(es) or former names _____

SSN [REDACTED]

Date of Birth

*In addition to providing your date of birth, you are required to provide supporting documents to prove your date of birth. See Section B, Appendix 2 for acceptable forms of proof.

Date of Birth [REDACTED]

Contact Information

Mailing Address Lance Huey

PO Box 583, Sheridan, AR 72150-0583

Phone Number (primary contact number) [REDACTED]

Email Address lancehuey1@gmail.com

Residency

Are you an Arkansas resident? Yes

If you are not an Arkansas resident, please identify your primary place of residence.

Have you been an Arkansas resident for the past seven (7) years? Yes

If you answered "yes" to the question above, in addition to providing the information requested below, you are required to provide supporting documents to prove your residency for the past seven (7) years. See Section B, Appendix 3 for acceptable forms of proof.

Provide the address of your primary residence(s) for the past seven (7) years. Identify the dates (month and year) you resided at each listed location:

11-1-16 to Present [REDACTED]
2-19-99 to 11-1-16 [REDACTED]

Tax Liability

Do you have any outstanding tax delinquencies owed to the State of Arkansas: No

If you answered "yes" to the previous question, please explain the nature of any delinquencies:

Other Financial Liabilities

Are you a party to any legal proceedings where damages, fines, or civil penalties may reasonably be expected to exceed \$500,000 above any insurance coverage available to cover the claim?

No

If the answer to the above question is “yes”, attach a statement describing the litigation, including the title and docket number of the litigation, the name and location of the court in which it is pending, the identity of all parties to the litigation, the general nature of the claims being made and the impact an unfavorable opinion may have on your ability to finance and operate the proposed cultivation facility. Any documents submitted in response to this requirement must be labeled with “Section B, Other Financial Liabilities”.

Regulatory History

Have you, or has any entity over which you exercised management or control, ever had any fines or other penalties over \$10,000 assessed by any regulatory agency? No

If the answer above is “yes”, attach a statement providing the details of such fines or penalties. Any documents submitted in response to this requirement must be labeled with “Section B, Regulatory History”.

Professional Licensure

Do you presently hold any type of professional license? NO

If yes, identify the type of license and license number _____

Is the license in good standing? N/A

Certification

I, LAURE HUEY, certify that the information provided in this form and its attachments is complete and accurate. I understand that any misstatement or concealment of fact may be grounds for refusal of application or revocation of license if later disclosed.

Signed this 13 day of August, 2017.

[Signature]
Signature of Applicant, Owner, Officer, or Board Member

Subscribed and sworn to before me this 18th day of August, 2017.

[Signature]
Notary Public

My Commission Expires: 9-1-21

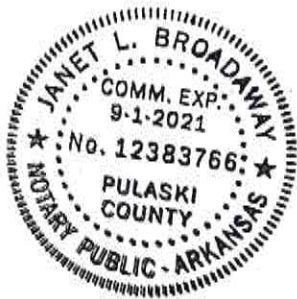

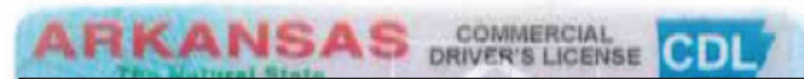

OWNERSHIP RECORD AND DESCRIPTION

Owner Name **HUEY, LANCE & ANNETTE**
 Property Address [REDACTED]
 Taxpayer Name **HUEY, LANCE & ANNETTE**
 Address [REDACTED]
 SHERIDAN AR 72150
 Exemption Status **Non-Exempt**
LEGAL DESCRIPTION

APPRAISAL SUMMARY

Land	22,500	Improvements	116,700	Total Appraised	139,200
Assessed Land	4,500	Assessed Improvements	23,340	Total Assessed	27,840

ASSESSMENT HISTORY

Year	Land	Improvements	Full Value	Effective Value	Homestead?	Comments
2016	4,500	23,340	27,840	27,840	Yes	AMENDMENT 79-REAPP Mass Updat
2013	4,500	23,520	28,020	28,020	Yes	ADV AMEND 79 Mass Update - Ad
2012	4,500	23,520	28,020	28,020	Yes	2012 ADV ASSESSMENT HIST/ ADV
2011	4,500	23,520	28,020	27,330	Yes	AMENDMENT 79 Mass Update - Pa
2010	4,500	23,980	28,480	26,190	Yes	AMEND 79 UPDATE Mass Update - Pa
2009	4,500	23,980	28,480	25,050	Yes	AMENDMENT 79 Mass Update - Ad

OWNERSHIP RECORD

Stamps	Price	Grantor / Grantee	Sale Date	Book/Page	Type	Remarks
0.00	88,000	APPLE TO HUEY	02/19/1999	212/509	WD	WD
0.00	11,000	APPLE	08/27/1998	211/307	WD	WD
0.00	74,000	BROWN TO BROWN & BOATRIGHT	06/01/1996	205/241	WD	WD INC

BUILDING PERMIT RECORD

Date	Amount	Purpose	District	Amount	Comment

IMPROVEMENT DISTRICTS

Date	Amount	Purpose	District	Amount	Comment

LAND RECORD

Use Code	Soil Code	Chr Sec	Front	Rear	Depth	Depth %	Size	Rate	Adjustment	Value
RESRS	M		0	0		1	1.00 Lc	22,500.00	1.00	22,500

COMMENTS

2016 REAPP AGE
 2011 REAPP AGE
 2008 REAPP AGE, GRADE +OPISLAND
 2003 REAPP GRADE/AGE. FOR 2002 ADD ROOMMWD
 2003 MAINT. PCA.

REVIEW RECORD

Action	Date	By	RES	USE CODES
PRINTED	08/16/17	GDE		
ENTERED	06/02/15	DCT		
INSPECTED	10/21/14	MWD		
ENTERED	09/06/10	MWD		
INSPECTED	03/19/10	MWD		
NOTICE	07/18/08	KDP		
NOTICE	06/30/08	MEL		
PRICED	06/29/07	MU		
APPRAISED	10/30/06	MB		

TOTALS										
							Acres	0.00		22,500

OCCUPANCY		STORY HEIGHT			GRADE		AGE		LIVING AREA		BASEMENT		BUILDING COMPUTATION					
Single Multi	Mobile	One	SL	One+	Two	Basic Grade	3	Built	1st Floor	2nd Floor	Unfinished	0	Base Price	33.69				
Family	Family Other Home					Adj %	0	Age	Future		Fin w/o Part	0	Grade Adj Factor	1.000				
X		X				Future Grade		REL	Future		Fin with Part	0	Grade +/- Factor	1.000				
						Future Adj %					Area	0	Story Height Factor	1.000				
EXTERIOR WALLS		HEAT & AC											ADJUSTMENTS TO BASE					
Masonry Veneer		Central			X								Foundation	1,950	0.00	0		
Comb Mas/Frame		Hot Air Forced											Floor Structure	1,950	0.00	0		
Standard Frame	X	Floor/Wall Furnace											Floor Insulation	1,950	0.00	0		
Lowcost Frame		Elec Base/Ceiling											Wall Insulation	1,950	0.00	0		
		Hot Water/Steam											Ceiling Insulation	1,950	0.00	0		
													Roof Cover	2,330	0.00	0		
		None											Plumbing Fixtures	0	532.00	0		
FOUNDATION		FLOOR COVER											Fireplaces	0	0.00	0		
Slab	X	Carpet/Vinyl		1950									Heat and A/C	1,950	3.07	5,987		
Closed Piers		Hard W/D/SHT		0									Floor Cover	1,950	1.78	3,471		
Open Piers		Hardd W/D/PQT		0														
FLOOR STRUCTURE		Linoleum		0														
Elevated Slab	X	Ceramic		0														
Wood Subfloor		Stone		0														
Slab On Grade		Softwood		0														
ROOF TYPE		None		0														
Hip		Gable	X	Area	1950													
Mansard		Flat		PLUMBING														
Gambrel		Dormer		Full Bath (3F)	2													
Arch		Shed		Half Bath (2F)	0													
ROOF COVER		Extra Charges			0													
Asphalt	X	Fiberglass		Rough-ins	0													
Wd Shng		Shakes		None														
Tile		Roll/Nil																
Other		Galvalume		FIREPLACE														
Area				Sq-1'S		Dbl-1'S												
INSULATION		Sq-1'S		Dbl-1'S														
Floor		Sq-1'S		Dbl-1'S														
Wall	X	Sq-1'S		Dbl-1'S														
Ceiling	X	Sq-1'S		Dbl-1'S														

YARD AND OTHER IMPROVEMENTS									
Item	Qty	Grade	Age	Rate	REL %	Loc Fact	HS	Value	
PCA FLAT	1				1.000	Y		200	
Total of all OBYI Items									200

ADDITIVE ITEMS				
Item	Qty	Rate	Factor	Total
CDW 16x40	640	2.00	1.000	1,280
CDW 16x25	400	2.00	1.000	800
CLPX4	80	5.21	1.000	417
CS 3x16	48	1.94	1.000	93
CS 3x20	60	1.94	1.000	116
FFAG	360	15.54	1.000	5,594
OP 4x5	20	14.28	1.000	286
PS	120	2.05	1.000	246
WD 11x20	220	6.71	1.000	1,476
WFX6	100	9.36	1.000	936

CALCULATION SUMMARY	
Replacement Cost New	86,398
Remaining Life %	87
RCNLD	75,166
Location Factor	1.550
Adjusted Value	116,507
Total OBYI	200
Total Value	116,707
Adjustment Factor	1.000
Final Value	116,707

Section B-Criminal History Report

ARKANSAS STATE POLICE

Arkansas Criminal History Report

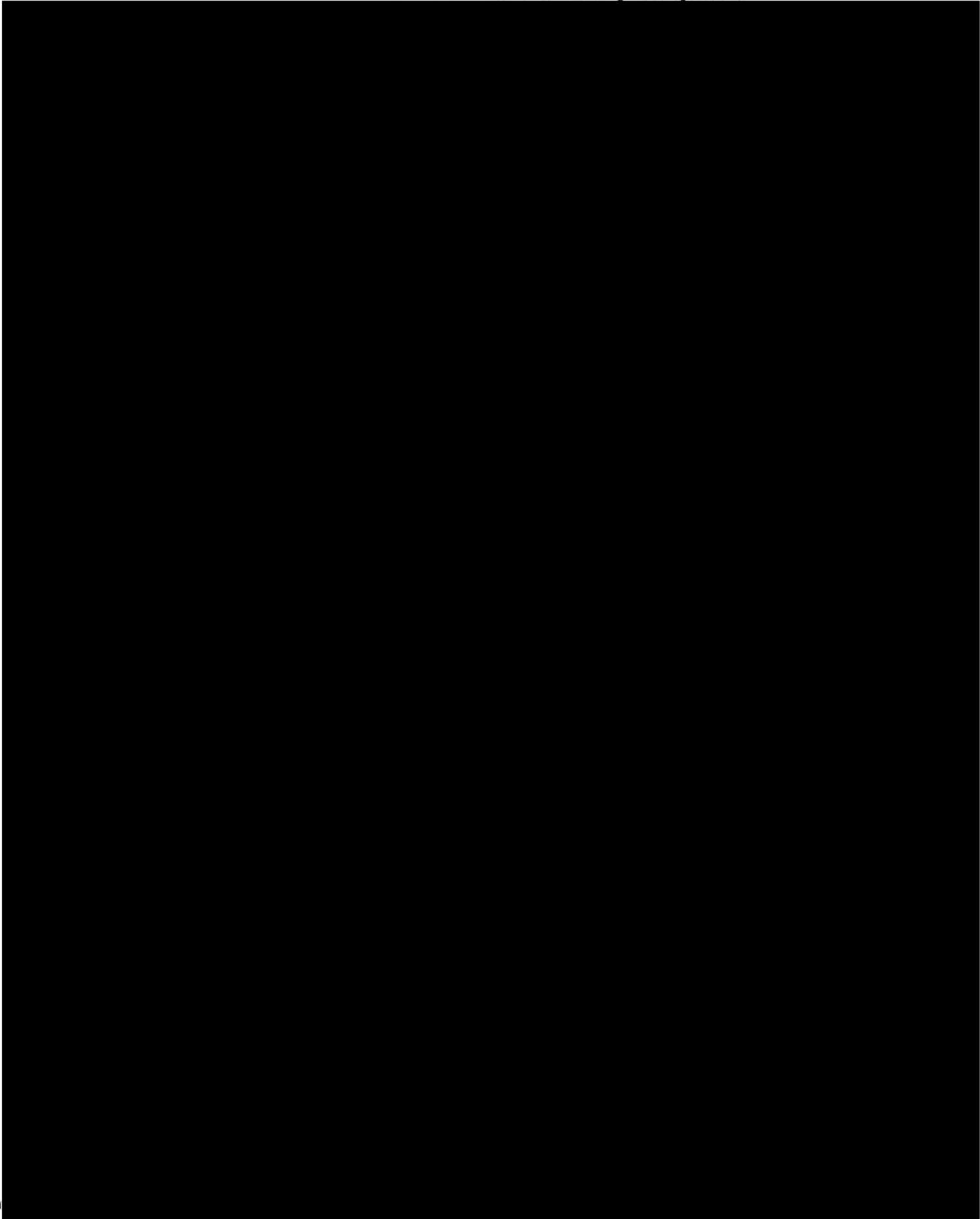

APPLICATION FOR MEDICAL MARIJUANA CULTIVATION FACILITY

SECTION B. Applicant, Owner, Officer, or Board Member Disclosure Statement

Identify your affiliation with the proposed cultivation facility (Applicant, Owner, Officer, Board Member?) Include your percentage of equity ownership in the facility, if any.

Affiliation: General Manager

Percentage of Equity Ownership: 0%

Legal Name

*In addition to the information below, you are required to provide supporting documents to prove your legal name. See Section B, Appendix 1 for acceptable forms of proof.

Last Name Fitch

First Name Terrence

Middle Name Anthony

Maiden Name (if applicable) _____

Alias(es) or former names _____

SSN [REDACTED]

Date of Birth

*In addition to providing your date of birth, you are required to provide supporting documents to prove your date of birth. See Section B, Appendix 2 for acceptable forms of proof.

Date of Birth [REDACTED]

Contact Information

Mailing Address [REDACTED]

[REDACTED]

Phone Number (primary contact number) [REDACTED]

Email Address taafitch@me.com

Residency

Are you an Arkansas resident? No

If you are not an Arkansas resident, please identify your primary place of residence.

Have you been an Arkansas resident for the past seven (7) years? _____

If you answered "yes" to the question above, in addition to providing the information requested below, you are required to provide supporting documents to prove your residency for the past seven (7) years. See Section B, Appendix 3 for acceptable forms of proof.

Provide the address of your primary residence(s) for the past seven (7) years. Identify the dates (month and year) you resided at each listed location:

 June 1997 to Present

Tax Liability

Do you have any outstanding tax delinquencies owed to the State of Arkansas: No

If you answered "yes" to the previous question, please explain the nature of any delinquencies:

Other Financial Liabilities

Are you a party to any legal proceedings where damages, fines, or civil penalties may reasonably be expected to exceed \$500,000 above any insurance coverage available to cover the claim?

No

If the answer to the above question is “yes”, attach a statement describing the litigation, including the title and docket number of the litigation, the name and location of the court in which it is pending, the identity of all parties to the litigation, the general nature of the claims being made and the impact an unfavorable opinion may have on your ability to finance and operate the proposed cultivation facility. Any documents submitted in response to this requirement must be labeled with “Section B, Other Financial Liabilities”.

Regulatory History

Have you, or has any entity over which you exercised management or control, ever had any fines or other penalties over \$10,000 assessed by any regulatory agency? **No**

If the answer above is “yes”, attach a statement providing the details of such fines or penalties. Any documents submitted in response to this requirement must be labeled with “Section B, Regulatory History”.

Professional Licensure

Do you presently hold any type of professional license? **No**

If yes, identify the type of license and license number _____

Is the license in good standing? _____

Certification

I, Terence A Fith, certify that the information provided in this form and its attachments is complete and accurate. I understand that any misstatement or concealment of fact may be grounds for refusal of application or revocation of license if later disclosed.

Signed this 25th day of August, 2017.

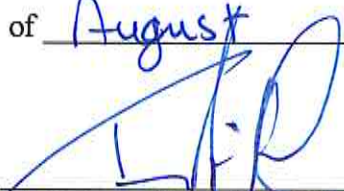

Signature of Applicant, Owner, Officer, or Board Member

Subscribed and sworn to before me this 25th day of August, 2017.

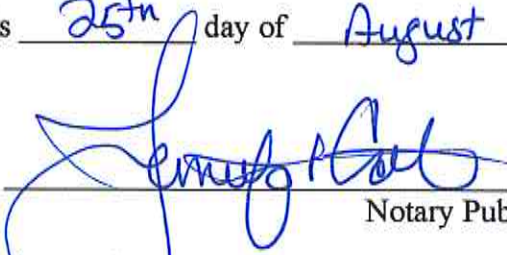

Notary Public

My Commission Expires: 4/6/2019

JENNIFER CATE
HOT SPRING COUNTY
NOTARY PUBLIC - ARKANSAS
My Commission Expires April 06, 2019
Commission No. 12370888

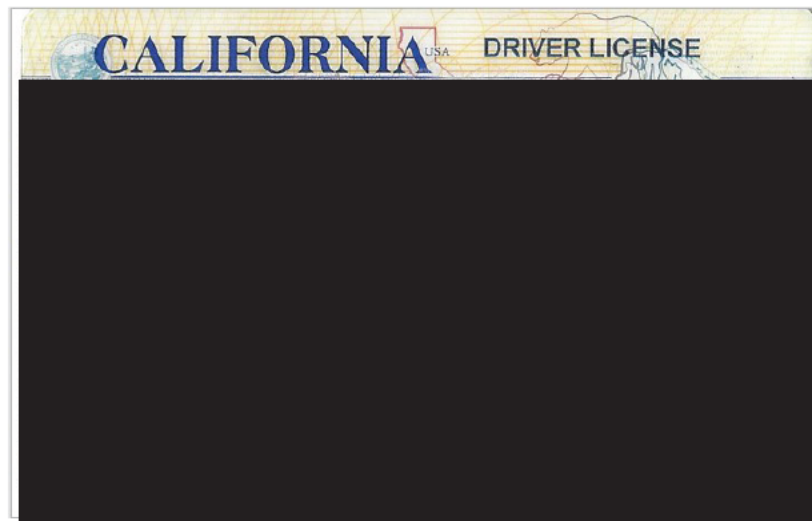

ARKANSAS STATE POLICE
Arkansas Criminal History Report

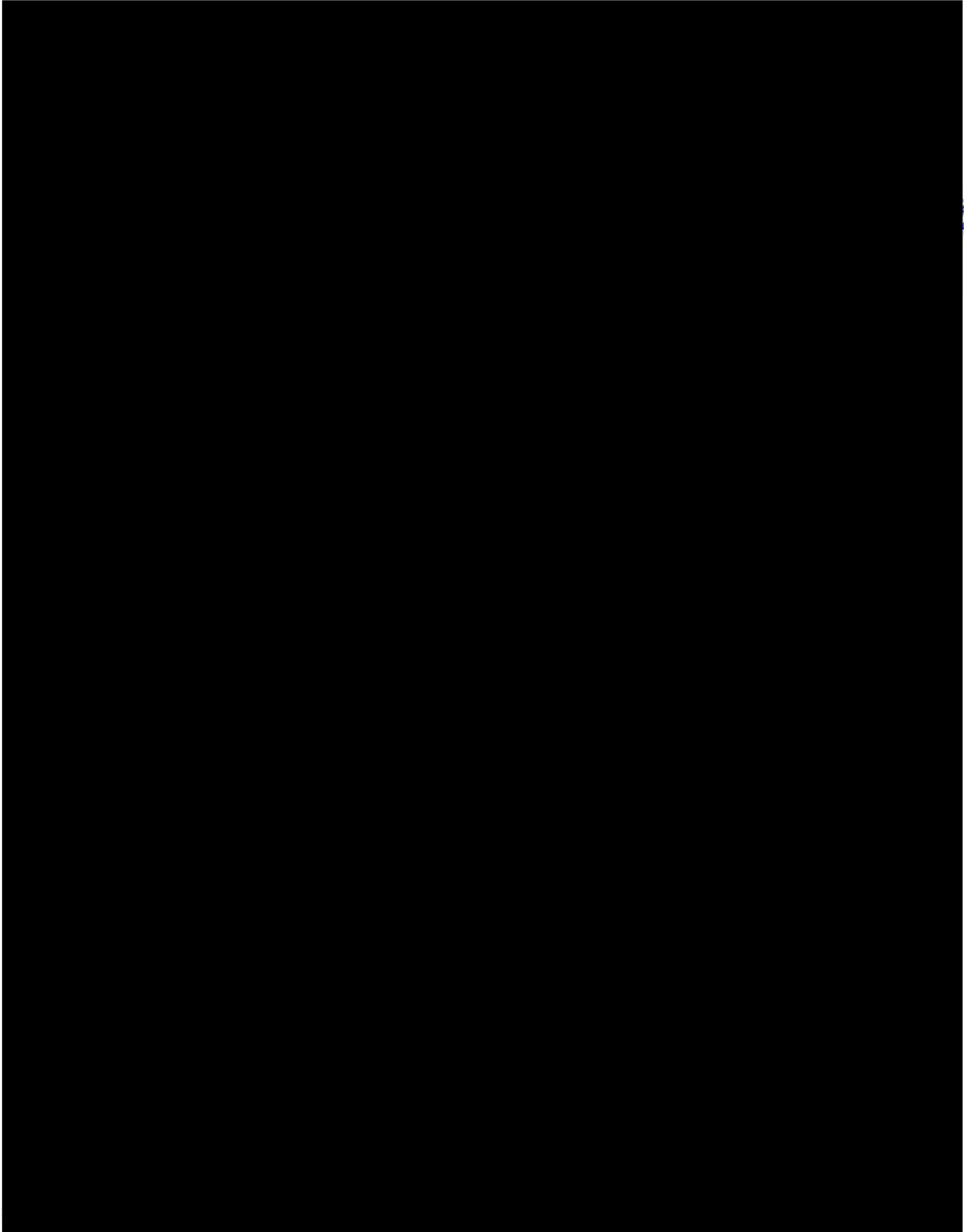

ARKANSAS

APPLICATION FOR MEDICAL MARIJUANA CULTIVATION FACILITY
SECTION C. PROPERTY INFORMATION

Part 1. PROOF OF AUTHORIZATION TO OCCUPY PROPERTY

NSMC-OPCO, LLC has chosen the third path of real estate compliance within Section C. Part 1. Attached beneath this document is a written statement from the owner certifying consent for NSMC-OPCO, LLC to purchase the property in Jefferson County for the purpose of operating a medical cannabis cultivation facility.

After a title search was performed, there was found to be zero lienholders or mortgagees.

EXHIBIT B
ACKNOWLEDGMENT OF INTENDED USE

[DATE] 9-6-17

Arkansas Medical Marijuana Commission
c/o Arkansas Alcoholic Beverage Control
1515 West 7th Street, Suite 503
Little Rock, AR 72201

RE: *Acknowledgment of Intended Use for 12.42 acres of Property Located Near the Intersection of Interstate 530 and Gravel Pit Road, Jefferson County, Arkansas, as More Particularly Described in Exhibit A (the "Property")*

Dear Sir or Madam:

I am the [Manager/Managing Member] of Sortay Investments, LLC ("Owner"), the current owner of the Property described above. The Owner recently contracted to sell the Property to NSMC-OPCO, LLC ("Buyer") upon terms and conditions contained in a Real Estate Purchase Agreement of even date herewith.

Owner understands and acknowledges that Buyer may, after acquisition of the Property, utilize the Property for the purpose of cultivation of medicinal cannabis sativa (or its derivatives), or related business, in accordance with licenses to be issued by state regulatory authorities established pursuant to Arkansas Constitutional Amendment 98.

Owner and/or affiliates of Owner continue own real property surrounding or adjacent to the Property. Owner has no objection to Buyer's intended use of the Property to grow or cultivate cannabis sativa (or its derivatives), or related business, in accordance with Arkansas law.

Sincerely yours,



[Manager/Managing Member]
Sortay Investments, LLC

140 Grant 167077
Sheridan, AR 72150

Part 2. PROOF THAT PROPOSED LOCATION IS AT LEAST 3000 FEET FROM THE NEAREST PUBLIC OR PRIVATE SCHOOL, CHURCH, OR DAYCARE.

NSMC-OPCO, LLC has attached below a survey of the property with a formal report proving that it is 3,000 feet from the nearest public or private school, church, or daycare.



Designing our client's success

GarNat Engineering, LLC

August 4, 2017

P.O. Box 116 (72018)
2909 Military Road
Benton, Arkansas 72015
PH: (501) 408-4650
FX: (888) 900-3068
garnatengineering@gmail.com

Joe Courtright
NSMC-OPCO, LLC
Dba Natural State Medicinals
One Allied Drive, Suite 1720
Little Rock, AR 72202

Re: Certification for School, Daycare and Church Setbacks
Natural State Medicinals
Jefferson County, Arkansas

Dear Mr. Courtright:

Please allow this letter to serve as my certification that the referenced project will not be located within 3,000 feet of any public or private schools, daycare centers, or churches.

To make this certification, employees of my firm drove the roads shown on the enclosed figure on July 27, 2017. We noted no schools or daycares along any of these roads. We did locate one church, which is also shown on the figure.

To certify the distance from the referenced property to the church, we surveyed the proposed southeast property corner of the referenced property and the northwest building corner of the church. The locations of those two points in state plain coordinates and the distance between them are listed in the following table.

Location	Northing	Easting
Southeast Property Corner Natural State Medicinals	N 1923644	E 1261682
Church of Living God 3120 Gravel Pit Road	N 1923242	E 1268355
Distance Between Points	6285 feet	

Section B, Part 2

If you have questions regarding our work or this certification, please do not hesitate to contact me.

Sincerely,

GarNat Engineering, LLC

Kelly Vanlandingham, P.E., P.S.

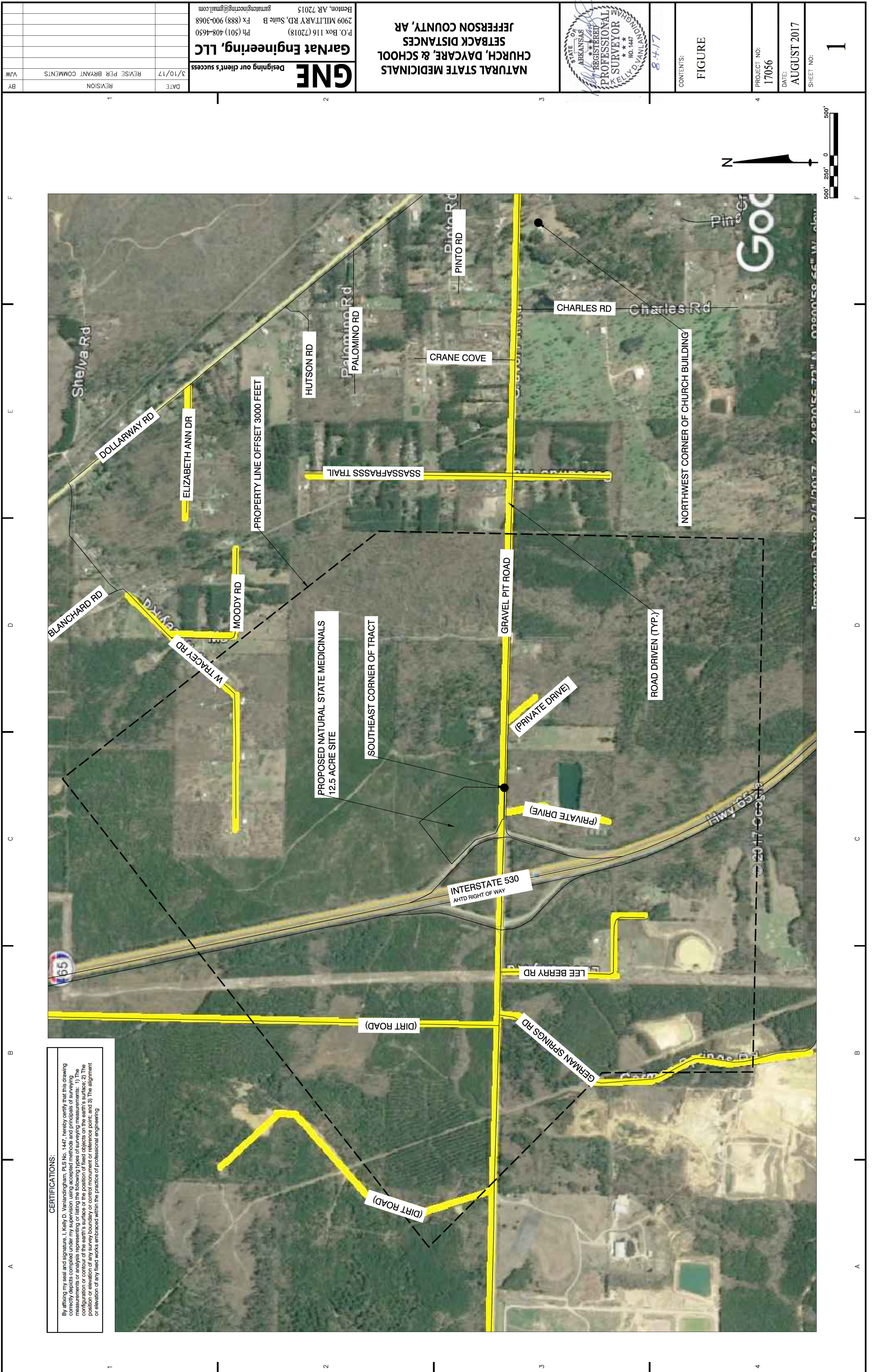

CERTIFICATIONS:
 By affixing my seal and signature, I, Kelly D. Vandenberg, PLS No. 1447, hereby certify that this drawing or sketch as indicated on this drawing was prepared using accepted methods and principles of surveying and that the measurements or analysis representing or listing the following types of surveying measurements: 1) The configuration or contour of the earth's surface or the position of fixed objects on the earth's surface; 2) The position or elevation of any survey boundary or control monument or reference point; and 3) The alignment or elevation of any fixed works embraced within the practice of professional engineering.

DATE	3/10/17	REVISION	REVISION PER BRYANT COMMENTS
BY			

GarNat Engineering, LLC
 Designing our client's success
 P.O. Box 116 (72018)
 2909 MILITARY RD, Suite B
 Benton, AR 72015
 Ph (501) 408-4650
 Fx (888) 900-3068
 gmatenginc@gmail.com

NATURAL STATE MEDICINALS
SETBACK DISTANCES
CHURCH, DAYCARE, & SCHOOL
JEFFERSON COUNTY, AR

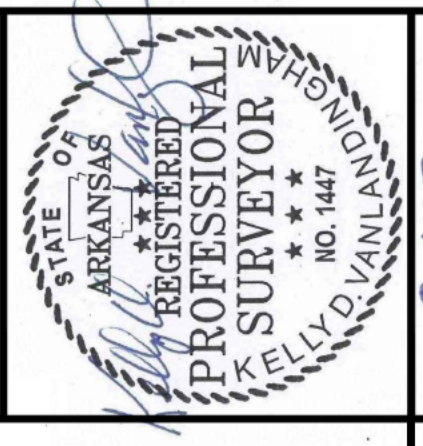

CONTENTS:	FIGURE
PROJECT NO:	17056
DATE:	AUGUST 2017
SHEET NO:	1

APPLICATION FOR MEDICAL MARIJUANA CULTIVATION FACILITY

SECTION D. COMPLIANCE WITH LOCAL ZONING RESTRICTIONS

Applicants for cultivation facilities must certify that the proposed cultivation facility will comply with any zoning restrictions enacted by the city, town, or county in which the facility is located.

Has the city, town, or county where the proposed cultivation facility is to be located enacted any zoning restrictions for medical marijuana cultivation facilities?

No

If you answered, “yes” to the question above, identify all restrictions and list the corresponding ordinance.

Certification

I, Joseph Charles Courtright, certify that if a license is awarded by the Medical Marijuana Commission, the cultivation facility to be located at: 1530 & Gravel Pit Road, Jefferson County, AR, will be operated in compliance with the zoning restrictions listed on Page 1 of this form.

Signed this 29th day of August, 2017.

Joseph Charles Courtright
Signature of Applicant

Subscribed and sworn to before me this 29th day of August, 2017.



Lindsey Forbes
Notary Public

My Commission Expires: November 26th, 2026



**Section C3 - Verification No
Zoning Required**

9-12-2017

Larry Reynolds
Executive Director
Southeast Arkansas Regional Planning Commission
1300 Ohio Street, Suite B
Pine Bluff, AR 71601

To whom it may concern,

Southeast Arkansas Regional Planning Commission serves as the planning agency for Jefferson County and the cities the county encompasses. Currently only three cities (Pine Bluff, White Hall and Redfield) have zoning ordinances in effect. Therefore, the property located near the unincorporated community of Jefferson, Arkansas at the northeast corner of the interchange between Gravel Pit Road and I-530, more specifically described as follows:

A PART OF THE SOUTHWEST QUARTER OF SECTION 23, TOWNSHIP 4 SOUTH, RANGE 11 WEST, JEFFERSON COUNTY, ARKANSAS, BEING MORE PARTICULARLY DESCRIBED AS FOLLOWS:

COMMENCING AT THE NORTHEAST CORNER OF SAID SOUTHWEST QUARTER; THENCE S 00° 26' 56" W A DISTANCE OF 1327.44 FEET TO A POINT; THENCE S 00°26'56" W A DISTANCE OF 1327.44 FEET TO A POINT ON THE SOUTH LINE OF SAID SECTION 23; THENCE N 88°51'13"W ALONG SAID SOUTH LINE OF SECTION 23 A DISTANCE OF 422.64 FEET TO THE POINT OF BEGINNING; THENCE S88°51'13"E A DISTANCE OF 371.38 FEET TO A POINT ON THE EAST RIGHT OF WAY LINE OF INTERSTATE 530; THENCE ALONG SAID RIGHT OF WAY LINE N00°17'15"W A DISTANCE OF 16.55 FEET TO FOUND ANGLE IRON; THENCE CONTINUING ALONG SAID RIGHT OF WAY LINE N64°52'25"W A DISTANCE OF 181.11 FEET TO A POINT; THENCE CONTINUING ALONG SAID RIGHT OF WAY LINE N18°32'00"W A DISTANCE OF 252.86 FEET TO A POINT; THENCE CONTINUING ALONG SAID RIGHT OF WAY LINE N45°07'56"W A DISTANCE OF 256.69 FEET TO A POINT; THENCE LEAVING SAID RIGHT OF WAY LINE N51°58'40"E A DISTANCE OF 623.67 FEET TO A REBAR AND CAP; THENCE S38°01'20"E A DISTANCE OF 677.74 FEET TO A REBAR AND CAP; THENCE S01°08'47"W A DISTANCE OF 473.24 FEET TO THE POINT OF BEGINNING, BEING A REBAR AND CAP; CONTAINING 12.42 ACRES, MORE OR LESS.

which the corporation JCNSM Properties, LLC or assigns is planning to use for a medical marijuana cultivation facility as defined in Arkansas Medical Marijuana Amendment of 2016, is under no zoning requirements within this area of Jefferson County, Arkansas.

Thereby, JCNSM Properties, LLC is legally allowed to conduct business at that location as a medical cannabis business as long as it meets all State requirements.

Sincerely,

Larry Reynolds
Executive Director
SARPC

Table Of Contents

Section E: Merit Criteria: Application for Marijuana Cultivation Facility

Chairman’s Introduction	1
Schedule 1: Qualifications of Applicant	5
Schedule 2: Ability to Operate a Cultivation Facility in Compliance with Applicable Law, Rules, and Regulations	
Schedule 2a: Plant Numbers, Strains, Marijuana Products	10
Schedule 2b: Construction Specifications	13
Schedule 2c: Security & Storage	16
Schedule 2d: Packaging, Labeling, & Preparation for Transport	18
Schedule 2e: Transportation	19
Schedule 3: Operations Plan	
Business Plan	20
Capital Breakdown and Debt Requirements	21
Daily Operations Schedules	22
Operational Timeline	22
Schedule 4: Financial Disclosure	22
Legal Sources of Finances Immediately Available to Begin Operating A Cultivation Facility	22
Disclosure of Bankruptcy Filings	22
Credit Histories of Owners	23
Summary of Owner’s Business’ Financial Statements	23
Schedule 5: Affiliation with a Medical Doctor, Doctor of Osteopathy, or Pharmacist	
Schedule 6: Economic Impact and Diversity	23
Schedule 7: Community Benefit	23

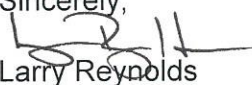
APPLICATION FOR MEDICAL MARIJUANA CULTIVATION FACILITY

SECTION E. MERIT CRITERIA

:

Section E Narrative to be added once final 25 pages have been created along with all relevant Section E attachments.

Section E Merit Criteria: Application for Medical Marijuana Cultivation Facility Natural State Medicinals Cultivation

SECTION E THE CHAIRMAN'S INTRODUCTION

As the Chairman and applicant for Natural State Medicinals Cultivation (NSM), I want to personally introduce you to our company by explaining our vision and story. Our group is formed entirely of medical and business professionals from the State of Arkansas. We are 100% locally owned with no plans of divesting. NSM is in no way a hidden partnership with outside investors subletting our professional accomplishments and Arkansas statehood. Our focus is on the cultivation and extraction of medical cannabis with zero members from our team applying for a dispensary license.

My background consists of 28 years in retail pharmacy. I was the President and CEO of the largest privately held pharmacy chain in the United States and headquartered in Pine Bluff, Arkansas. As President and CEO, I oversaw 157 pharmacies, over 500 pharmacists and 4,000 employees. Our company also owned and operated the largest wholesale pharmaceutical business in Arkansas, being licensed to distribute controlled substances in 32 states. The Committee has asked applicants to demonstrate experience in regulated industries and I have included a list of 1,302 licenses from my previous company, please see Exhibit 1 for this list. These range from DEA, pharmaceutical distribution, alcohol, tobacco, lottery and medical equipment across multiple states. I have never had a license suspended or revoked.

NSM's promise will be to provide our patients with the highest quality medical grade products specific for their medical condition in the most controlled, secure, and regulated manner possible. I have spent my entire professional career doing such. In addition, I am an owner and member of the Board of Directors of two steel building manufacturing companies.

Our Owners: I would like to provide you a snapshot of our team of owners and advisors. As stated earlier, we are all Arkansans having a combined 562 years of residency. Our ownership is 52% female and 25% minority. I also want to note that all equity is from invested capital on equal terms. No equity has been exchanged for services or products; only for invested capital. Our combined balance sheet represents a net worth of \$195m.

Owners from the medical community include a leading urologist and adjunct professor at the University of Arkansas for Medical Science with a focus on cancer, a renowned neurosurgeon, a neurologist specializing in epilepsy and ALS, a gastroenterologist with 24 years of service on the Arkansas State Medical Board, a dietitian, a PhD biomedical engineer and a veterinarian. NSM's six-member Medical Advisory Board owns 43% of the company. Furthermore, one of our owners has been working with software developers specializing in the cannabis industry for two years. He is licensed by Colorado to work in the spent great amounts of time working with Colorado's seed-to-sale platform and has been licensed by the state to do such.

From a business perspective our owners include the senior leadership of USA Drug, the previously mentioned retail pharmacy chain I headed, as well as the founder of the generic pharmaceutical distribution business. Collectively, we are the owners of a neurosurgery center, MRI imaging center, multiple medically focused IT businesses, a point-of-sale and security business, endoscopy center, outpatient surgery center, a specialty pharmacy, as well as a non-profit focused on aiding cancer survivors. From an agriculture perspective, our group owns an Arkansas produce wholesale distribution business and multiple farms totaling well over 1,000

Section E Merit Criteria: Application for Medical Marijuana Cultivation Facility Natural State Medicinals Cultivation

acres and includes multiple owners of timberlands and wetlands. When objectively evaluating the ownership and leadership goals of the MMC, our team should meet and exceed the highest of expectations.

Our Advisors: A major focus for the successful implementation of Arkansas, Medical Marijuana program will be to establish both compliance and security. For compliance, we have retained the services of both a leading Arkansas attorney and a former U.S. Attorney as our third-party Director of Compliance. There will be ongoing, arms-length, quarterly compliance reviews. The only way to establish superior compliance and security is to engage an independent firm with no ownership or stake in the company.

Our Director of Security, a Marine Corps veteran, has an extensive career in both Arkansas law enforcement as well as a highly regulated business. He spent over 20 years as an Arkansas State Trooper prior to being elected as Sheriff of Grant County where he served two terms. At that time, the Arkansas Lottery Commission was newly formed and had a task very similar to that of the Arkansas Medical Marijuana Commission; the task being to run a highly regulated new business where security is paramount. He was the inaugural Director of Security for the Arkansas Scholarship Lottery. He was tasked with hiring and screening staff as well as the secure transportation of tickets, security, and maintaining the integrity of the program. Lance's long-time experience will be invaluable in establishing good working relationships with law enforcement officials on all levels throughout the state. We clearly have someone that has done this before. NSM is committed to ensure both the safety of our supply chain I headed as well as the safety of our employees. This has been clearly outlined in our security sections.

We aim to establish NSM as the leading producer and manufacturer of high grade, medical cannabis products ensuring the utmost in consistency and outcomes with our product mix. We are fully committed to ensuring that our business has the most proven and best practices for the medical cannabis industry, including but limited to: cutting-edge cultivation processes, pharmaceutically formulated manufactured products, and control measures, and best in class security protocols. We will be relying on three key individuals each with a specialized focus on the procedures, production, and research of medical cannabis in Arkansas.

Our general manager is a former Arkansas resident who became a 20-year senior executive at a Fortune 100, highly regulated beverage manufacturer. His vast experience in creating standard operating procedures (SOPs) has further translated into the cannabis cultivation vertical of the cannabis industry. He owns three best-in-class cultivation facilities in Denver while simultaneously holding positions on various cannabis industry boards.

Our cultivation manager will be relocating to Arkansas to supervise all aspects of the production of our product. His experience includes years of founding and operating legal cannabis cultivation facilities in Colorado. He has proven effective expertise in the execution of light spectrum, temperature, CO2, water levels, humidity, root development, and nutrient deployment for optimal cannabis production, quality control, and quality assurance. That is explained throughout our application and in detail in NSM's Exhibits. Every potential cultivator in Arkansas is seeking an out of state, experienced production and cultivation expert. I firmly believe we are importing the best one.

Section E Merit Criteria: Application for Medical Marijuana Cultivation Facility Natural State Medicinals Cultivation

In regards to plant research and genetics, our Director of Agriculture and Genetics is a native Arkansan, with a Ph.D. from the University of Arkansas in plant breeding and genetics. After graduation, he had a lengthy career with Monsanto overseeing the development of a global cotton-breeding pipeline between the U.S., India, and Brazil. He currently owns and operates a 400-acre produce farm in Arkansas.

Our process of growing is very “high touch.” We choose to manually complete key tasks that could be automated. The reason for this is we want to visually observe for the early stages of disease, pests, or underperforming strains. Moreover, our group uses a process of manual “schwazzing,” a process and term created by our Colorado advisors. In layman's terms, this is a highly detailed, proprietary defoliation process, similar to pinching back your tomato plants. It requires additional labor, but it is proven to increase key medicinal compounds, quality, and yields just like all of our cultivation and extraction processes. A beneficial side effect of this is the creation of more jobs for local Arkansans with our ultimate goal being the creation of the highest grade product.

State-of-the-Art Facility Design: Now I would like to briefly discuss the location, architecture, and design of our facility. We retained the services of [REDACTED], a nationwide architectural firm with extensive experience designing manufacturing facilities including those in the pharmaceutical industry. Our engineering firm from Colorado has extensive experience with designing superior cannabis production facilities.

We initially considered purchasing existing warehouse space to retrofit as a cultivation facility. However, we quickly decided against this, to construct a fully process- engineered, and expandable facility. Designing and building a cultivation facility from the ground-up is the only way to achieve a high-quality yield, maintain pristine growing conditions, and ensure the integrity and consistency of our cannabis genetics. While this choice does greatly increase the upfront costs of starting this business, we have found it to be absolutely necessary to achieve our internal goal of consistently manufacturing pharmaceutical-grade medical cannabis products within Arkansas.

Our design consists of smaller-sized cultivation rooms. Our advisors have developed this approach over the years and determined a smaller, [REDACTED] ft² room greatly increases the biochemical consistency as well as the individual quality of each plant. We are not taking a “sea of green” approach that leads to biological contamination, but rather a much more controlled method that lowers the price patients will pay for our product, increases the amount of pharmaceutical-grade cannabis produced, and eliminates any form of biological contamination.

We also believe it is critical to design not just for the short-term, but also have a plan in place for smart, future expansion. As will be illustrated later, our Phase I facility will be [REDACTED] ft². We have designed three phases with a potential growing capacity of [REDACTED] ft². I know as commissioners you have read of supply issues in other states. We want our facility to be well positioned to meet the growing demands of the State of Arkansas.

We understand that location is important in its effect on other Arkansans. It is safe to say that no individual or business would be excited about having a cultivation facility next door due to economic, political, social, sensory, or religious reasons. We are designing our building with the highest grade filtration system available, however, it would be impossible not to detect some

**Section E Merit Criteria: Application for Medical Marijuana Cultivation Facility
Natural State Medicinals Cultivation**

scent during a harvest. In order to have positive community relations, we have therefore chosen this remote location. This location is miles from almost any existing business, other than a waste management plant, which is nearly one mile away, and there are scarcely any residences within miles of our location. We chose to prevent any issues with neighbors up front, respecting the local communities of Arkansas rather than battling with them.

Research and Data Analysis: Another unique aspect to NSM is that to truly achieve our health care goal, we needed to develop a mechanism to address some of the unknowns in medical cannabis. There is not currently an efficient manner to track strain-specific outcomes nor is there a time-tested method to cross-check drug interactions with medical cannabis. Lastly, we are all keenly aware of the opiate addiction crisis occurring in the United States as well as in our home of Arkansas.



Community Impact and Sustainability: NSM is dedicated to benefiting the local community in which it operates as well as the state of Arkansas as a whole. Because of this core value to have a positive community impact, we will be locating our new facility in Jefferson County. We are all aware of the declining economy of Jefferson County and we are delighted to bring new, well-paying jobs and new revenue to such an underserved area. We are committed to providing not only well-paid positions, but long-term careers to the citizens of Jefferson County.

We will not be hiring anyone from outside of Arkansas to run or operate this facility other than our initial two medical cannabis advisors who will train everyone below them. When we sold our corporate headquarters in Pine Bluff, seeing the loss of jobs was excruciating. It will be very rewarding to help bring them back.

Furthermore, NSM has done extensive research on the qualifying conditions that are present in Jefferson County. Even though NSM will only be cultivating, extracting, and selling medical

Section E Merit Criteria: Application for Medical Marijuana Cultivation Facility Natural State Medicinals Cultivation

cannabis to licensed dispensaries in the state of Arkansas, NSM feels responsible for the well-being of the residents of Jefferson County. NSM discovered that Jefferson has higher rates of epilepsy within the state. NSM has chosen to allocate resources to ensure that several of the strains produced and manufactured products will specifically be for epileptic patients of Jefferson County.

NSM understands that the future is in sustainable cannabis production and business practices. As such, our company is preparing for the acquisition of a LEED certification. NSM wants to minimize negative impact on the local community and environment along with enhancing its positive impact. As a result, NSM will be employing USDA-certified-organic inputs and methodologies including innovative integrated pest management techniques that enhance plant immunology through environmental management, soil microbes, and symbiotic insects.

NSM wants to keep the Natural State, natural. We believe this starts with sustainable agriculture, environmentally smart building processes, and a philosophy that is dedicated to providing the highest quality medicine without any impurities to any immunologically compromised patients of Arkansas.

A Personal Note: I want to close with a testimonial from one of our owners and our Director of Communications. She lost her daughter to a lengthy battle with colon cancer. Like any parent, she left no stone unturned to try to bring her daughter comfort and relief. It was recommended that she try medical cannabis, something she previously would not allow in her household. Eventually, she decided to try it. It did not save her daughter's life, but it was unquestionably effective as an antiemetic and the increased appetite her daughter experienced greatly improved her quality of life. In closing, that is what we hope to do. We want to improve the quality of life for Arkansans with qualifying conditions for medical cannabis. Your service as a commissioner may seem like a thankless job, but you are definitely bettering the health of our state. Our team greatly appreciates your service and will certainly respect the tough decisions you are tasked to make.

SCHEDULE 1 - QUALIFICATIONS OF APPLICANT

Joe Courtright, P.D., R.Ph, Owner, Board of Directors Chairman: Joe has experience working in a *regulated field* - he began his pharmacy career in 1989 as a pharmacist for May's Drug Stores, Inc., ascending to Senior Vice President of Pharmacy and Information Technology. Joe most recently served as President and CEO of USA Drug, the largest privately-held pharmacy chain in the U.S. During his tenure, he oversaw 153 pharmacies, over 500 pharmacists, and 4,000 employees. USA Drug also owned and operated the largest wholesale pharmaceutical business in Arkansas with controlled substance distribution capability in 32 states. See Exhibit 1 for a list of 1,302 licenses from Joe's previous companies, ranging from DEA, pharmaceutical distribution, alcohol, tobacco, underground gas, eggs, Western Union, EBF, Class VII Liquefied Petroleum, lottery, to medical equipment across multiple states. Additionally the controlled substance distribution business and a subset of pharmacies required both *24/7 monitoring and armed security*.

In 2003, Joe designed and developed the first multi-location, multi-state, online *secure inventory tracking system* for pseudoephedrine and methamphetamine precursor products. Joe also implemented sound *financial and business planning* through the generation of 71 retail pharmacy acquisitions. He orchestrated the sale of the Memphis, TN market of USA Drug and

Section E Merit Criteria: Application for Medical Marijuana Cultivation Facility Natural State Medicinals Cultivation

Ike's Deep Discount to Walgreens. In 2010, Joe oversaw the redemption of certain shares of USA Drug which made USA Drug the largest privately-held pharmacy chain in the U.S. with a total valuation at purchase of \$214 million. In 2012, Joe orchestrated the sale of USA Drug and seven subsidiary companies to Walgreens with a total purchase price in excess of \$550 million, which represented a gain of approximately \$453 million and an IRR of 30.3%.

Joe is on the Board of Directors for KPH Healthcare, a national provider of pharmaceutical and health care services with complementary businesses in retail and commercial segments of these industries. The company is comprised of Kinney Drugs, with 100 full-service drug stores, Health Direct Institutional Pharmacy Services for long-term care needs, ProAct, Inc., a national pharmacy-benefit management company and mail order pharmacy, and Noble Health Services, a specialty pharmacy dispensing complex and chronic disease medications. KPH has annual revenue over \$1 billion and 3,000 employees.

Joe was on the Board of Directors of the National Association of Chain Drug Stores, representing drug stores totaling 40,000 pharmacies, 3.2 million employees including 178,000 pharmacists. Joe was also on the Board of Directors of Data-Rx, which provides pharmacy technology services in the United States. Joe is also a board member and owner of Associated Steel Group, which is a steel building *manufacturing* company with annual revenues of \$125 million. In 2017, Joe became the fifth recipient of the University of Kansas, School of Pharmacy Distinguished Service Award.

Terence Fitch, General Manager: Terence is a previous Arkansas resident and Fortune 100 company senior executive. While working as the President of the Western United States for Coca-Cola Enterprises, he managed and was responsible for 75 *manufacturing plants* and sales centers with over 7 million ft² of manufacturing space. Under his direction, his plants consistently scored at the top of the industry for efficiency, bottling over 6,000 Coca-Cola bottles per minute and manufacturing over 1,500,000 cases of Coca-Cola a day. He personally oversaw the distribution of each of those cases whereby he managed over 5,000 semi-trucks in 16 states.

As a senior executive, Terence also developed and executed numerous *business plans*. Under his leadership, annual sales grew to over \$4.2 billion, with seven regional vice-presidents directly reporting to him. These plans encompassed but were not limited to: go-to-market strategies, competition analysis, *regulatory compliance*, resource allocation, distribution, marketing, sales, and the annual budget with emphasis on examining returns on investment for repairs, maintenance, and expansion of new manufacturing plants, employees, and distribution pathways.

Additionally, Terence has experience in the *highly regulated cannabis cultivation industry* where he managed the operations of 3 cultivation facilities in Colorado with a combined annual production of 12,000 pounds of cannabis and over 65 employees. His experience in creating SOPs, managing sophisticated operations, and navigating complicated regulatory environments translates well into the cannabis cultivation industry. Terence has served on the Board of Directors of MassRoots since 2015, the premier publicly-traded social network for cannabis. Through this expansive experience, Terence also has experience with *secure Inventory Tracking and Control* and *operating a business with 24-7 security*.

Stephen LaFrance, Owner, Board of Directors: Stephen has experience in the highly *regulated industry* of pharmaceuticals. He joined USA Drug as owner and operator of 6 drug

Section E Merit Criteria: Application for Medical Marijuana Cultivation Facility Natural State Medicinals Cultivation

stores in 1993. Stephen developed the company's acquisition strategy to purchase and consolidate independent drug stores and small chains into the USA Drug family of companies. Prior to its sale to Walgreens in September 2012, USA Drug was the 6th largest drugstore chain in the United States as well as the largest privately owned pharmacy chain with 157 pharmacies.

Stephen founded the generic pharmaceutical distribution arm of SAJ distribution. That company owned and operated the largest wholesale distribution business in Arkansas with controlled substance distribution in 32 states. This *required DEA mandated 24-7 security, inventory tracking and control.*

In addition, Stephen was the founder, President, and CEO of six corporations which owned and operated 32 drug stores in five states, all separate from USA Drug. These stores produced over \$200 million in annual revenue. While orchestrating USA Drug's rapid growth, Stephen formed LAF Brothers Properties, LLC to manage commercial real estate investments. LAF Bros owns over 30 properties in seven different states. After the sale of the family business to Walgreens, Stephen formed a private wealth management office, Dale Capital Partners, Inc., with Stephen as a main Principal officer and owner. Having had P&L responsibility, Stephen has ample experience *creating and implementing sound business plans and financial plans.*

Stephen also has extensive experience in the field of *agriculture and horticulture.* He is the former owner and manager of Diantha West Farm which cultivated rice and soybeans on a 653 acre farm and AG Resource, LLC which cultivated wheat, rice, and soybeans. Stephen currently owns AG Resources II, LLC, which cultivates soybeans and wheat, and Yo Eleven Enterprises, LLC, which owns an investment in a company that grows trees in Sheridan, Arkansas.

Robert DeBin, Owner, VP IT and Business Development: Robert is an Arkansas native and cannabis industry IT expert. He graduated from the Walton College of Business with a degree in Entrepreneurship and Information Systems, also receiving a graduate certificate in SAP Enterprise Resource Planning. After graduating, he founded RockIT City Solutions, an IT services & consulting firm, specializing in payment processing and tablet *point of sale* systems for restaurants and retail stores, as well as networking, and security services. Robert is licensed with the Payment Card Industry Security Standards Council as a Qualified Integrator & Reseller.

After the passing of Colorado (CO) Amendment 64 his business pivoted, offering IT consulting services to the growing *cannabis industry* in CO. Robert holds CO's Marijuana Enforcement Division's Occupational Support License to legally work with cannabis manufacturers and retailers. He has worked with medical marijuana point-of-sale providers as well as advised dispensary operators and *cannabis cultivators* to help streamline their IT practices. While working in Colorado, Robert completed training in METRC, the first *all-regulatory*, seed-to-sale solution for cannabis. Over the past year, Robert has been working directly with our *cultivation* and *extraction* advisors in CO receiving hands-on training in their *cultivation, production, sales, security, and compliance* procedures. His experience and understanding of *point of sale* and *inventory tracking* with experience and training in *seed-to-sale tracking software* will help NSM establish best practices for compliance. Through this work he has also gained ample experience *creating and implementing sound business plans and financial plans.* Robert is a member of the Board of Directors for the Arkansas Cannabis Industry Association, a cannabis trade

Section E Merit Criteria: Application for Medical Marijuana Cultivation Facility Natural State Medicinals Cultivation

association advocating for laws, regulations and public policies that foster a healthy, professional and accountable medical cannabis industry in our state.

Andrew Salini, Cultivation Manager: Andrew is a Princeton University graduate with a strong background in creating *financial plans* as he was a strategist and portfolio manager from 2011-2014 at EMF, a fixed income hedge fund with \$500 million AUM. Andrew also worked for 5 years as an investment banker at Deutsche Bank and later Credit Suisse. He has experience with *developing and implementing business plans, secure inventory and tracking systems,* and *operating a business that requires 24-7 security and monitoring* as he oversees the operations of three *cannabis cultivation* facilities and four dispensaries in Colorado for High Country Healing, an industry leader both in Colorado and in the United States. High Country Healing has won numerous awards for its cultivated artisan cannabis using proven USDA organic methodologies. High Country Healing has consolidated annual revenues of \$10+ million. High Country Healing prides itself on being socially responsible and forward thinking with patient-friendly branding. More specifically, High Country Healing has created a color labeling program for specific chemotypes which will be used by NSM to further develop its own medicinal identification and classification program for patients in Arkansas. Andrew will be relocating to Arkansas to supervise all aspects of the production of our product. His experience includes years of founding and operating legal cannabis cultivation facilities in Colorado.

Dr. Scott Schlesinger, Owner, Medical Advisory Board of Directors: Dr. Scott Schlesinger has extensive experience working in a heavily *regulated industry* as he has practiced neurosurgery in Little Rock for over 25 years. He has experience *implementing sound business plans* and *financial plans* through his practice and surgery center, which employ 50 full-time employees managed in compliance with the Center of Medicare Services (CMS) highly-regulated federal “Conditions of Coverage” rules, and which treats 3,000 patients annually. He is responsible for extensive compliance programs including state and federal reviews and credentialing from the Department of Health and CMS every 2-4 years. He was actively involved with the 2017 Legislative Act 820 regarding the prescription drug-monitoring program. As CEO and CMO of the surgery center, he provides full-time oversight of management, *24-7 security,* and *secure inventory tracking and control* of medical supplies and medications including controlled substances. Scott has hands-on experience with *commercial manufacturing* as his family owned and operated a successful aluminum alloy manufacturing and recycling business, Arkansas Aluminum Alloys.

Josh Risley, Laboratory Manager: In 2015, Josh partnered to open Cannabis Maximus, a profitable, *well-regarded,* and licensed *cannabis concentrate manufacturing company, which requires 24-7 security.* The laboratory Josh and his team designed and built meets FDA clinical standards along with achieving OSHA safety compliance (Class I Division I) to ensure it will withstand the ever-tightening *regulations* around light hydrocarbon cannabis extractions. Cannabis Maximus pioneered the process for true Class I Division I cannabis extraction processing globally and locally. Eight months after opening, Cannabis Maximus grosses between \$100,000 - \$120,000 per month, has 20 employees, and its products are sold in over 40 Colorado retail dispensary locations. Cannabis Maximus is recognized as one of the premier concentrate brands in Colorado.

Section E Merit Criteria: Application for Medical Marijuana Cultivation Facility Natural State Medicinals Cultivation

Dr. Alonzo Dean Williams, Sr., MD, Owner, Medical Advisory Board of Directors - Dr. Williams Sr., has experience in the *highly regulated industry* of healthcare and pharmaceuticals as a gastroenterologist of thirty years and medical director for Arkansas Diagnostic Center and Kanis Endoscopy Center, a fully accredited outpatient surgery center in Little Rock, Arkansas. He is a 24-year member of the AR State Medical Board. Dr. Williams also owns D&D Specialty Pharmacy in Little Rock, and serves as CEO of Pacific Coast Management, which owns and manages over 25,000 f² of healthcare real estate and provides management for several private practices. He oversees all these facilities, which require *24-7 monitoring and security*.

Dr. Donna M. Mooney, Ph.D., Owner, Medical Advisory Board of Directors: Has a B.S. in Chemistry and Computer Science, an M.S. in Computer Science and a Ph.D. in Electronics and Instrumentation. Dr. Mooney has experience working in a *highly regulated industry*, and she conducted her Post Doctorate in the Department of Pediatrics where she designed, programmed and implemented a non-invasive human fetal heart rate monitor. Many of today's monitors employ her algorithms. Donna develops integrated solutions for patients' Electronic Health Records (EHRs), and has written complex certified medication prescription modules for Surescripts, the national prescription drug repository. She is a partner in Bespoke Health Media, LLC, and has developed a patient education application "MDspoke" for targeted guidelines-based patient education and patient medical records. She also has experience in *agriculture* as she owns a produce company in Little Rock and Hot Springs. She has extensive knowledge in the areas of food safety and Good Agricultural Practices. Her produce companies supports "Arkansas Grown" and has a statewide distribution network.

Dr. Keith Mooney, Owner, Medical Advisory Board of Directors: Dr. Mooney is a Board Certified Urologist who has extensive experience in the *highly regulated* field of healthcare. He has been President of Arkansas Urology for over 12 years and Adjunct Professor of Medical Sciences, Urology at the University of Arkansas. He has been recognized by the Arkansas Times for Best Doctors--Urology (18 years), Best Doctors-Urology for the Decade and by Arkansas Business for Best Urologist (18 years), and Most Compassionate Doctor (3 years).

Frank Groves, Ph.D., Director of Agriculture and Genetics, Advisory Board: Dr. Groves has his Ph.D. in plant breeding and genetics and an *M.S. in Agriculture* with a focus on *Weed Science*. He brings 20 years of experience in the field. He had a lengthy career with Monsanto overseeing development of a global cotton-breeding pipeline among the U.S., India, and Brazil. He has experience *creating and implementing a business plan* in 2016. Specifically, having launched an 80-acre startup farm focused on the development of sustainable and innovative *produce farming* practices in the Arkansas Delta. Later, Frank formed Benson Creek Produce, LLC. *Benson Creek Produce is a 400-acre operation* that has earned regional recognition as a premium brand in the market.

E. ("Bud") Cummins, Third-Party Compliance Officer: Has experience working in a *regulated industry* as an attorney licensed in good standing in Arkansas since 1989. His law firm is Law Offices of Bud Cummins, PLC. Mr. Cummins served as a federal law clerk to a U.S. Magistrate Judge and to the Chief U.S. District Judge for the Eastern District of Arkansas. He was Chief Legal Counsel to Governor Mike Huckabee and was a presidentially appointed U.S. Attorney for the Eastern District of Arkansas from 2001 to 2006. Mr. Cummins' private law

**Section E Merit Criteria: Application for Medical Marijuana Cultivation Facility
Natural State Medicinals Cultivation**

practice specializes in compliance, internal investigations, litigation, and federal criminal defense.

Dr. Kelli Schlesinger, Owner, Medical Director: Dr. Schlesinger has experience in the *highly regulated* industry of healthcare as a neurologist who diagnoses, treats, and manages brain and nervous system disorders with an emphasis on patient comfort and care. She holds honors such as Excellence in Patient Care and Chief Resident in Neurology. She is currently a member of the American Medical Association, American Academy of Neurology, American Association of Neuromuscular and Electrodiagnostic Medicine, and the American Headache Society.

Lance Huey, Director of Security: Lance enlisted in the United States Marine Corps in 1983 and served for seven years. He attained the rank of Sergeant (E-5) and was honorably discharged in 1990. Lance has an extensive career in Arkansas law enforcement and highly regulated business. Lance spent over 20 years as an Arkansas State Trooper prior to being elected as Sheriff of Grant County for two terms. At that time, the *Arkansas Lottery Commission was newly formed and had a task very similar to that of the Arkansas Medical Marijuana Commission*. Lance was the inaugural Director of *Security* for the Arkansas Scholarship Lottery. He was tasked with hiring and screening staff as well as securing the transportation of tickets. Sheriff Gerald Robinson of Jefferson County trusts in Mr. Huey’s abilities to ensure the safety of Jefferson County, abide by the state law, as well as the rules of the medical marijuana commission. His letter of endorsement is included as Exhibit 1.99.

Detailed biographies of our ownership and advisory teams, which are organized alphabetically, can be reviewed by referring to Exhibits 1.1. (Ownership Team) and 1.2 (Advisory Team), and the overall organizational structure can be reviewed in Exhibit 1.3 (Organizational Chart).

SCHEDULE 2a

Plant Numbers, Strains, Marijuana Products:

[REDACTED]

[REDACTED]	[REDACTED]	[REDACTED]	[REDACTED]	[REDACTED]
[REDACTED]	[REDACTED]	[REDACTED]	[REDACTED]	[REDACTED]
[REDACTED]	[REDACTED]	[REDACTED]	[REDACTED]	[REDACTED]

[REDACTED]

Cultivation Procedures:

[REDACTED]

**Section E Merit Criteria: Application for Medical Marijuana Cultivation Facility
Natural State Medicinals Cultivation**



Grow Mediums:

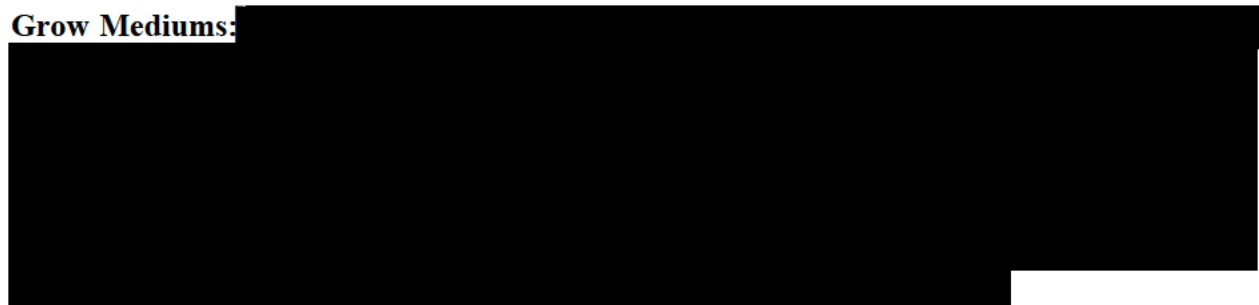

Pesticides and Integrated Pest Management:



**Section E Merit Criteria: Application for Medical Marijuana Cultivation Facility
Natural State Medicinals Cultivation**

[Redacted]

Types of Areas to be Used in the Cultivation of Plants at Various Stages of Growth:

[Redacted]

Product Manufacturing:

[Redacted]

[Redacted]

Detailed Testing plan:

[Redacted]

**Section E Merit Criteria: Application for Medical Marijuana Cultivation Facility
Natural State Medicinals Cultivation**

[REDACTED]

Prevention of cross contamination of plants:

[REDACTED]

Waste disposal:

[REDACTED]

[Exhibit 2.7](#) for NSM's full process diagram. See [Exhibit 2.23](#) for Disposal of Waste Products.

SCHEDULE 2b - CONSTRUCTION SPECIFICATIONS

Material used in Construction:













[REDACTED]

[REDACTED]

**Section E Merit Criteria: Application for Medical Marijuana Cultivation Facility
Natural State Medicinals Cultivation**



SECURITY LEGEND

-  ACCESS CONTROLLED DOOR (PROX, REED, DPS, STYRE)
-  ACCESS CONTROL BIOMETRIC READER
-  INTRUSION DETECTION SYSTEM MONITORED DOOR (DOOR POSITION SWITCH)
-  INTRUSION DETECTION SYSTEM KEYPAD
-  INTRUSION DETECTION SYSTEM MOTION DETECTOR
-  SILENT DURESS BUTTON
-  PANIC (ALARM) BUTTON
-  ALARM STROBE/SPIN
-  CALL VIDEO INTERCOM STATION
-  MASTER VIDEO INTERCOM STATION
-  CAMERA (POLE MOUNT)
-  CAMERA (WALL MOUNT)
-  CAMERA (CEILING MOUNT)

Phase 1



TREANORHL

SCHEDULE 2c - SECURITY & STORAGE



Alarm System:



Surveillance System:

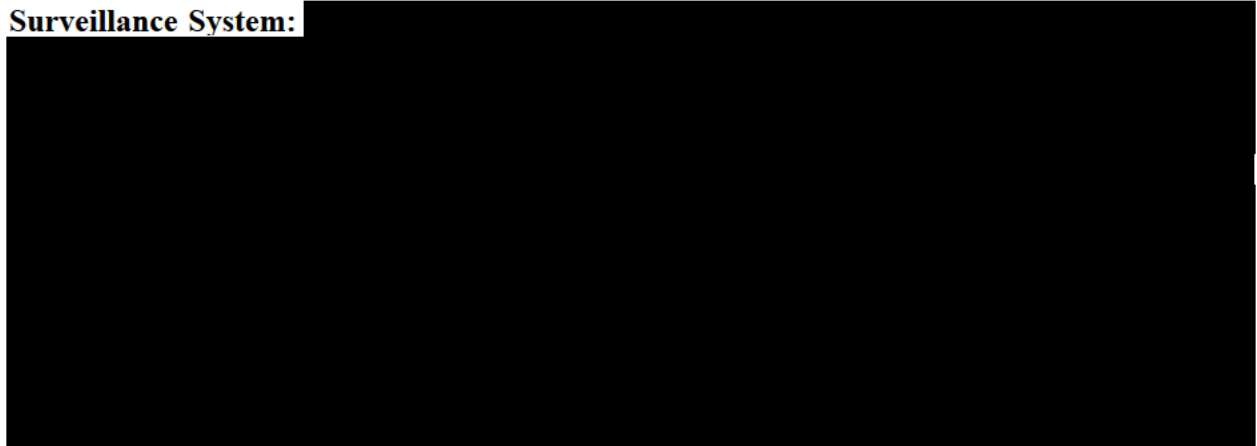

**Section E Merit Criteria: Application for Medical Marijuana Cultivation Facility
Natural State Medicinals Cultivation**



Perimeter:



Retention Plan:



Additional Plans or Methods for Security: For details on how NSM will implement additional security measures including locks and latches, monitoring of different access areas, access permissions and credentials, daily inspections, employee criminal disqualifiers, and employee training, please see the 7-page [Exhibit 2.28](#).

Storage of medical cannabis:

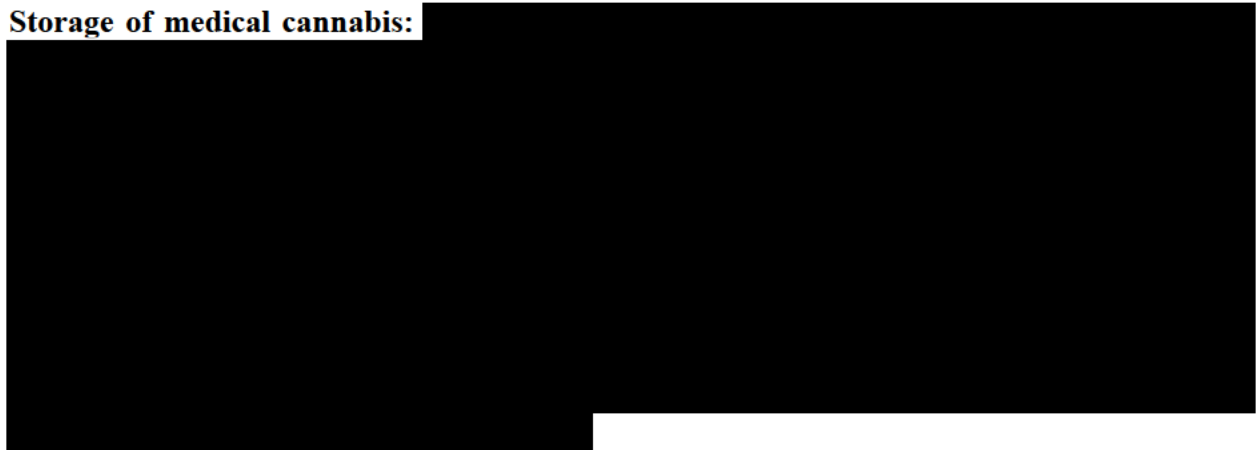

SCHEDULE 2d - PACKAGING, LABELING, & PREPARATION FOR TRANSPORT

NSM will ensure that its medical cannabis products are packaged and sealed in containers that fully comply with RR.13 and the Arkansas State Board of Health Department of Health Section V. A summary of NSM's Labeling, Packaging and Preparation for Transport processes can be

**Section E Merit Criteria: Application for Medical Marijuana Cultivation Facility
Natural State Medicinals Cultivation**

reviewed below. But, first we will describe a vital part of tracking our products--our Inventory Tracking System.

Inventory Tracking Solution:



Packaging of Medical Cannabis Products:

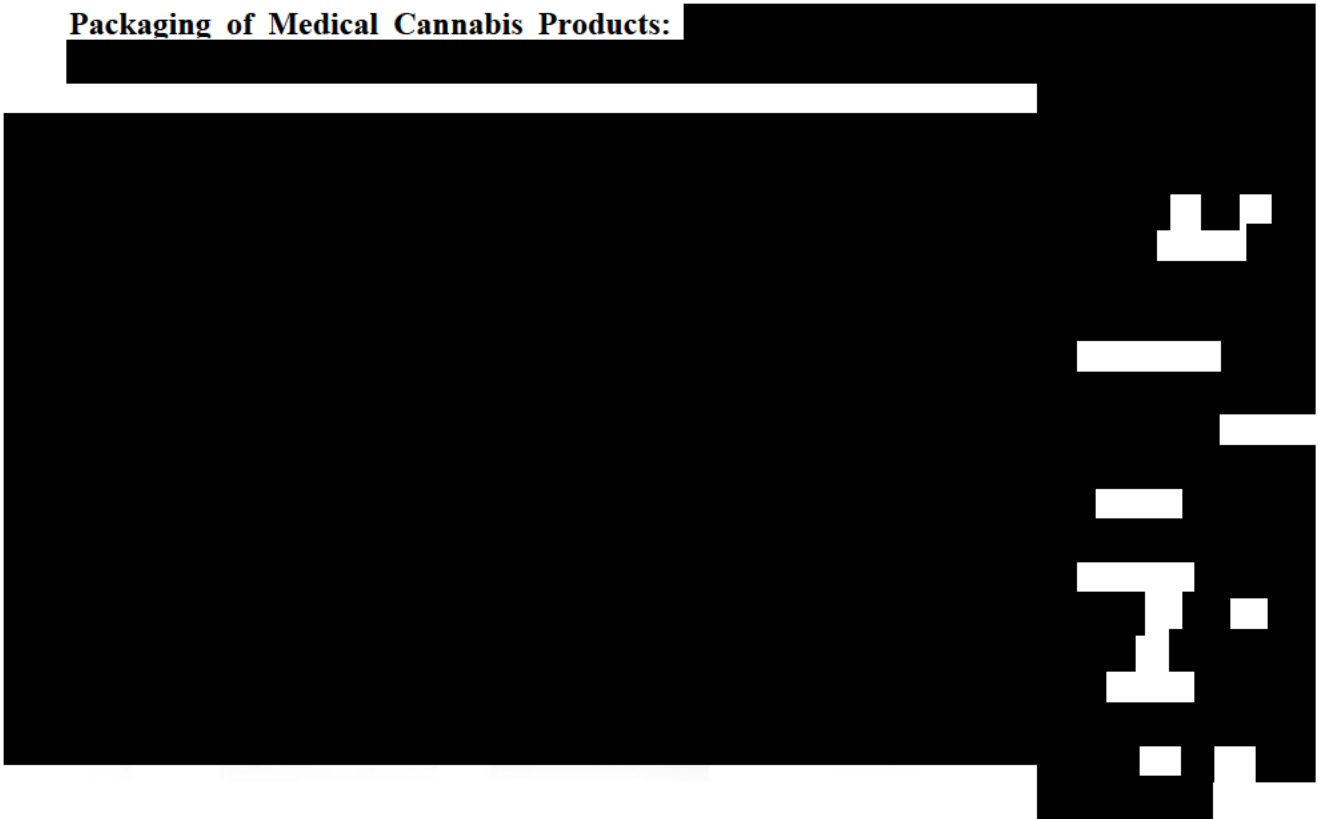

Packaging Images: Photos/Diagrams of NSM's packaging and containers are in Exhibit 2.46.

Labeling of Medical Cannabis Products: NSM will exceed Arkansas's Department of Health Rules and Regulations, Section V. labeling guidelines, and our product labels will be printed in both English and Spanish. None of the packaging will be attractive to children, or show any insignia or brand that could mislead the customer. Labels will contain the required information

**Section E Merit Criteria: Application for Medical Marijuana Cultivation Facility
Natural State Medicinals Cultivation**

for each product, with data furnished by the ERP. NSM will use a combination of printing labeling information directly on the packaging, well as printing labels to be applied to packaging and informational leaflets to be included with the products. Because patient health and safety is of the utmost importance to our company, NSM will adhere to, and exceed, the Department's rules and regulations governing medical cannabis labeling. Images of our labels, along with corresponding policies and procedures regarding labeling are inclusive of all state requirements and can be reviewed in Exhibit 2.33.

**Process for Weighing,
Packaging, and Preparing
Medical Cannabis for
Transport:**

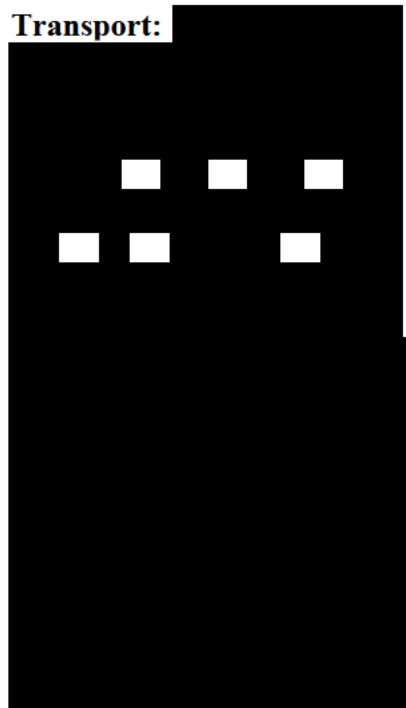

2e - TRANSPORTATION



**Section E Merit Criteria: Application for Medical Marijuana Cultivation Facility
Natural State Medicinals Cultivation**



SCHEDULE 3 - OPERATIONS PLAN

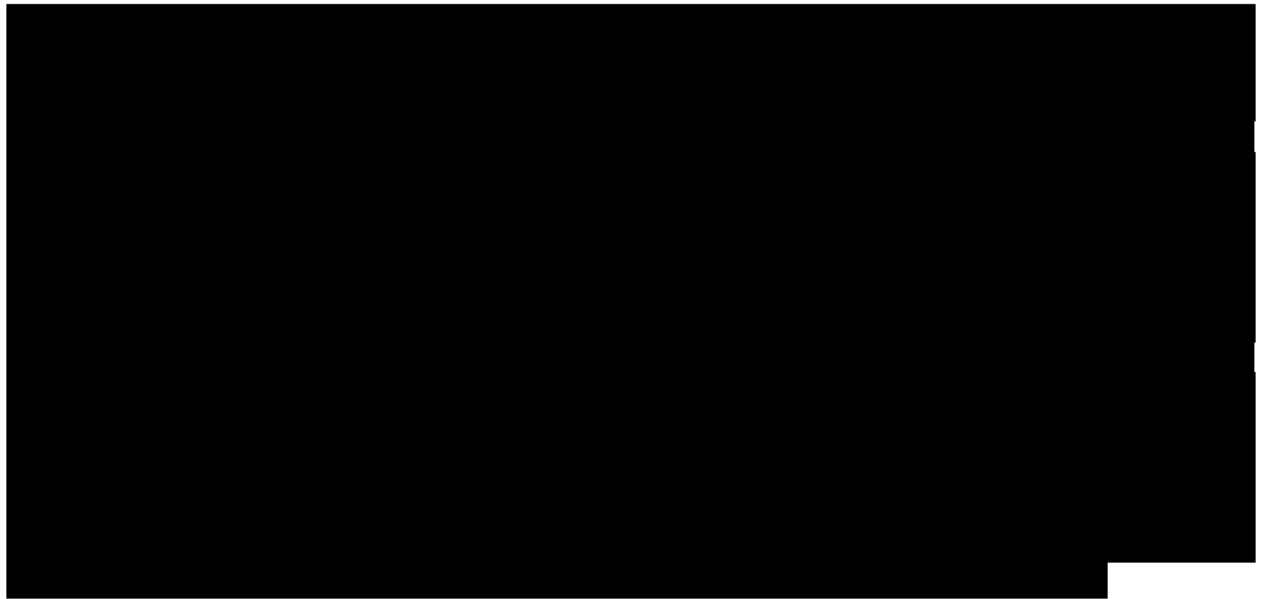

Business Plan for Operating a Cultivation Facility:

Executive Summary: NSM’s powerhouse team includes “on-the-ground” knowledge and experience in the cannabis industry. Our management contains Fortune 500 business, medical cannabis cultivation, extraction, pharmacy, entrepreneurship, and knowledgeable medical professionals. Collective distribution, compliance, security, and business scaling experience will allow them to thrive in the cannabis industry. NSM believes in patient wellness via quality of life, and wishes to create economic development throughout Arkansas by generating tax revenue, jobs and careers for its residents. NSM’s business plan is based on the American Herbal Pharmacopoeia’s practices for cultivating cannabis and the pharmacy, agricultural, cannabis, business, and medical experience in its team. By implementing compliance, successful cultivation strategies, a seed-to-sale tracking system, outstanding SOPs, customer-centered care, security, and sustainable processes, NSM will create, regulate, and through its licensed dispensary customers, deliver compliant pharmaceutical-grade cannabis and products to licensed

**Section E Merit Criteria: Application for Medical Marijuana Cultivation Facility
Natural State Medicinals Cultivation**

dispensaries supporting Arkansas’s medical patients in need. Responsible processes will ensure that the medicine is consistently of the highest quality. NSM will build its cultivation facility from the ground up, ensuring hyper-compliance, safety, community satisfaction, and superb cannabis quality; it will be environmentally-monitored with worker safety and compliance to OSHA and WPS standards, efficiency, Arkansas Department of Health and Alcoholic Beverage Control Division regulations, and state and local laws. NSM vows to create a positive effect on the community, including economic development, jobs, and active law enforcement and community dialogues.

Market Analysis:

[REDACTED]

Organization and Management: The individuals, their titles, experience, skills, and considerable qualifications are described extensively in Schedule 1. Staffing requirements and hiring criteria are described below. See Exhibit 3.4 for NSM’s organizational chart.

Marketing and Sales: NSM will have a direct sales force initially consisting of a sales manager and two sales representatives to help educate and maintain good working relationships with NSM’s customers. In conjunction, NSM will develop an online distribution ecosystem to connect with dispensaries. This will enable dispensaries to see real-time inventory and pricing of all of NSM’s products. This platform will integrate with our [REDACTED] and the state’s seed-to-sale platform providing for online wholesale ordering for dispensaries with the option for real-time oversight by the state.

Capital Breakdown & Debt Commitment:

[REDACTED]

Staffing & Hiring Criteria: Hiring quality, qualified staff will be key to NSM providing the safest, most compliant medical cannabis in Arkansas. NSM will first focus on recruiting veterans from the community. The executive team will hire vetted cultivation facility managers and employees who can be properly trained to uphold high standards and carry out operations in

**Section E Merit Criteria: Application for Medical Marijuana Cultivation Facility
Natural State Medicinals Cultivation**

strict accordance with NSM’s comprehensive operations model and quality assurance processes. NSM’s Phase 1 buildout will employ 75 Arkansans including cultivators, support staff, and managers. NSM’s explicit *hiring policies* will be compliant with all Arkansas regulations as detailed in Exhibit 3.9. Exhibit 3.10 describes our Staffing Structure/Requirements.

Daily Operations Schedules: NSM will adapt and implement existing comprehensive SOPs from advisors in Colorado that will extend to all its daily operations. These procedures will hold NSM management and employees accountable for daily operations and identify individual and collective responsibilities. NSM’s SOPs include best cannabis business practices defined by American Herbal Products Association’s recommended cannabis business practices, USDA Organic Standards, American Herbal Pharmacopoeia Quality Standards, USDA Good Agricultural Practices and Good Handling Practices, FDA Good Manufacturing and Good Laboratory Practices, and the World Health Organization's Good Dispensing Practices. In addition, procedures will include Medical Advisory Board practices. Standard daily operating procedures will be kept in all operations areas. Directors and managers will ensure employees follow procedures and are held accountable for compliance, revisions, or improvements. See Exhibit 3.8 for detailed cultivation and extraction daily operations schedules.

Operational Timeline:



SCHEDULE 4 – FINANCIAL DISCLOSURE

Legal Sources of Finances Immediately Available to Begin Operating a Cultivation Facility:

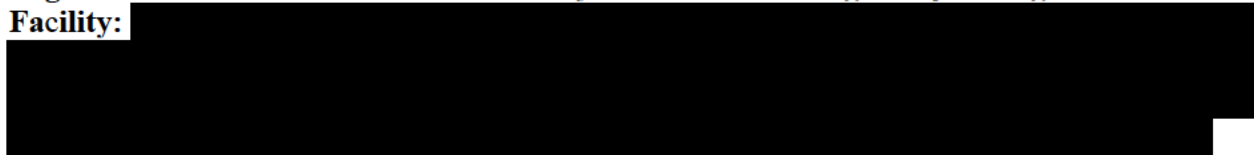

Disclosure of Bankruptcy Filings by the Applicant or Entities Owned or Operated by the Applicants: Neither NSM nor any of its equity holders or entities owned or operated by them have had any bankruptcy filings in the past 8 years (Exhibit 4.4).

Credit Histories for the Applicant and Owners of the Entity: The average credit score of NSM’s equity holders is approximately [redacted]. Exhibit 4.1.

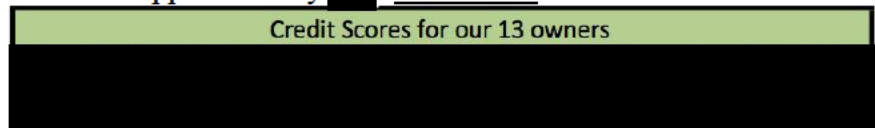

**Section E Merit Criteria: Application for Medical Marijuana Cultivation Facility
Natural State Medicinals Cultivation**

Summary of Financial Statements for Applicant Owners' Businesses:

Any Other Information That May Be Necessary to Prove Financial Stability: To conclude, NSM is extensively well financed through its equity holders. NSM does not expect to ever seek outside financial resources. NSM is well equipped, considering the financial responsibility of its equity holders, to handle this endeavor, and all owners of NSM are ready to execute this opportunity and eager to make it successful for the State of Arkansas and its patients.

SCHEDULE 5 – AFFILIATION WITH AN MD, DO, OR PHARMACIST

1. Kelli Schlesinger, M.D., Neurologist, Natural State Medicinals - Equity Holder
2. Scott Schlesinger, M.D., Neurosurgeon, Natural State Medicinals - Equity Holder
3. Donald Mooney, M.D., Urologist, Natural State Medicinals - Equity Holder
4. Alonzo Williams, M.D., Gastroenterologist, Natural State Medicinals - Equity Holder
5. Joe Courtright, P.D., R.Ph, Pharmacist, Natural State Medicinals - Equity Holder

SCHEDULE 6 – ECONOMIC IMPACT AND DIVERSITY

Schedule 6a: NSM is located in Jefferson County, Arkansas. See Exhibit 6.1 for the Property Description Tracks 1 & 2 and the Survey of Location.

Schedule 6b: NSM is 51.6% women-owned and 24.9% minority-owned. Under the new Arkansas Minority Business Enterprise Certification Program NSM is 60% minority-owned. See Exhibit 6.2.

SCHEDULE 7 - COMMUNITY BENEFIT

Schedule 7a (Substance Abuse Plan) and 7c (Research Plan): Our Country and State are in the midst of an undeniable opiate crisis. Arkansas is frequently rated in the top 10 states for opiate utilization. Amazingly, the US represents 4.5% of the world's population, yet we consume 80% of global opiate supply and a shocking 99% of the global hydrocodone supply. With the majority of our owners being medical professionals or researchers, NSM is uniquely qualified to identify a mechanism to help battle **substance abuse** and facilitate development of a clinical data repository for cannabis **research**. This effort was spearheaded by two owners. Dr. Donna Mooney Ph.D. is a biomedical researcher specializing in developing complex medical prescription modules. In addition to degrees in both Chemistry and Computer Science, she also has a Ph.D. in Electronics and Instrumentation. Dr. Frank Groves Ph.D. has over 20 years' experience as a plant researcher at Monsanto. His education includes an M.S. Degree in Agriculture as well as a Ph.D. in plant breeding and genetics.

The strength of our ownership team has positioned us to internally develop a **research** tool that is both highly unique and focused on producing measurable and impactful outcomes.

**Section E Merit Criteria: Application for Medical Marijuana Cultivation Facility
Natural State Medicinals Cultivation**



**Section E Merit Criteria: Application for Medical Marijuana Cultivation Facility
Natural State Medicinals Cultivation**

[REDACTED]

[REDACTED]

[REDACTED]

[REDACTED]

[REDACTED]

[REDACTED]

Schedule 7b: [REDACTED]

Schedule 7d: NSM's ownership is 100% Arkansas residents.

Lastly, we realize there is great opportunity for financial gain for those chosen to be issued a cultivation license. NSM knows it is our obligation to give back to the community. NSM is committed to using a portion of its profits to help enable the efforts of two existing local charities, the Little Rock Police Foundation and Yoga Warriors Fighting Colon Cancer. In line with our commitment to our veterans we will establish a needs-based scholarship fund for veterans and their children.

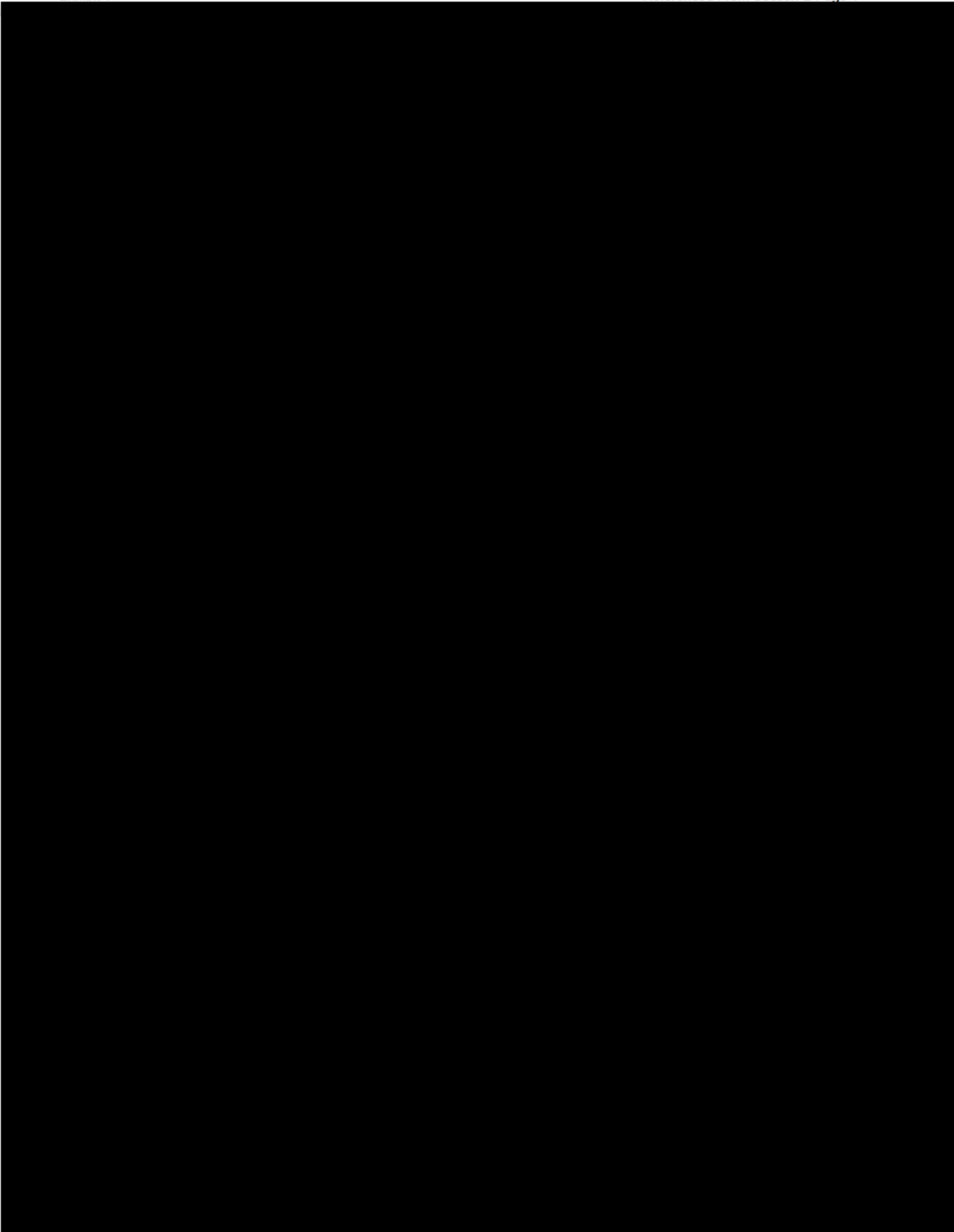

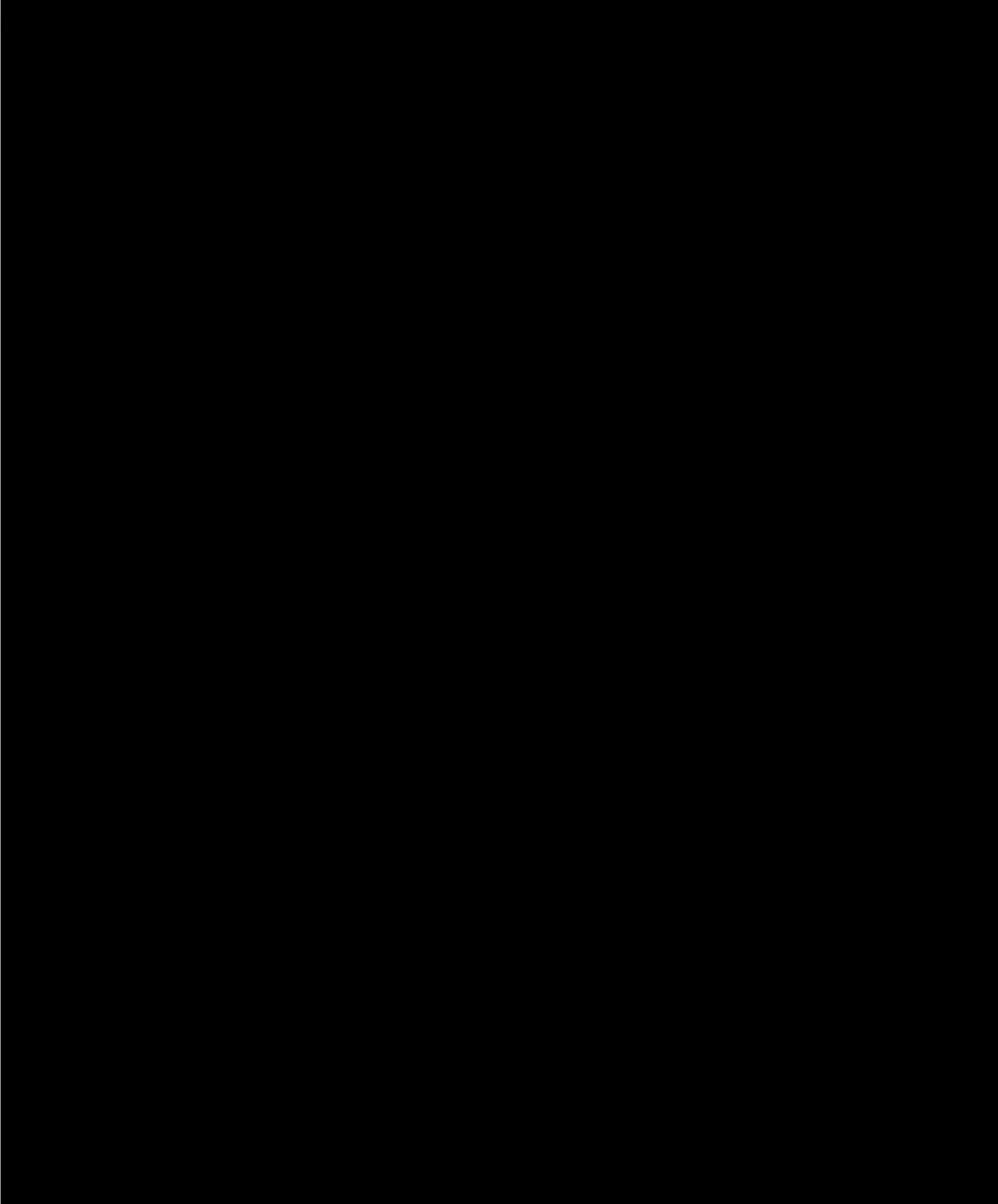

EXHIBIT 1.1 OWNERSHIP TEAM BIOGRAPHIES

ALONZO D. WILLIAMS, SR., M.D

Alonzo Dean Williams, Sr., MD a native of West Helena, Arkansas. Dr. Williams currently serves as gastroenterologist and medical director for Arkansas Diagnostic Center and Kanis Endoscopy Center, a fully accredited out-patient surgery center in Little Rock, Arkansas. Dr. Williams is sole owner of D&D Specialty Pharmacy in Little Rock, Arkansas. He currently serves as CEO of Pacific Coast Management, which owns and manages over 25,000 sq. ft. of healthcare real estate and provides practice management for several private practices.

Dr. Williams has been a practicing gastroenterologist for over 30 years and a consulting physician for Baptist and St. Vincent hospitals and a former member of the Arkansas State Medical Board.

Dr. Williams is an alumni of Arkansas State University (ASU), where he received his BS in Zoology in 1973 and received his Doctor of Medicine and Specialty training from University of Arkansas for Medical Sciences (UAMS) in 1979 and completed his fellowship in gastroenterology in 1984.

Dr. Williams is a well-known authority on the issues of colon cancer, and has been recognized numerous times for his work to eliminate colon cancer in Arkansas. Dr. Williams was sole owner of Kanis Endoscopy Center from 1989-2009, until entering a partnership with Covenant Surgical Partners, Inc. of Nashville, TN. Dr. Williams is current the medical director and a major stock owner of Kanis Endoscopy Center. Under his leadership Kanis Endoscopy Center has been awarded accreditation from AAAHC (Accreditation Association for Ambulatory Health Care, Inc. for nine years.

Dr. Williams has served on numerous distinguished boards including the Arkansas State Medical Board for 24 years, serving from 1994-2008, Covenant Surgical Partners Medical Advisor Board, PARK (Positive Atmosphere Reaches Kids), AMDPA (Arkansas Medical, Dental, Pharmaceutical Association, and founding president of 100 Black Men Association of Arkansas.

He is committed to the community and promoting economic development in Arkansas.

EXHIBIT 1.1 OWNERSHIP TEAM BIOGRAPHIES

ALONZO D. WILLIAMS, SR., M.D

BORN: March 18, 1951 in West Helena, Arkansas

PRE-MEDICAL EDUCATION: Arkansas State University, Jonesboro, Ark
1960-1973; B.S. in Zoology; Minor in Chemistry
1973-1974; graduate work in school of Business

MEDICAL EDUCATION: University of Tennessee Medical Units, Memphis TN
1974-1975; Dental school

University of Arkansas for Medical Sciences, Little Rock
1975-1979; **M.D.** Degree
979-1980; Medical Internship
1980-1982; Medicine Residency
1982-1984; Gastroenterology Fellow

POST-GRAD. QUALIFICATIONS:

Flex- December, 1979
American Board of internal Medicine 1983
Gastroenterology, Eligible 1985

SUBSPECIALTY:

EMPLOYMENT HISTORY:

University of Arkansas for Medical Science (UAMS)
1979-1984

Arkansas Diagnostic Center P.A. (Medical Director)
1984-Present

Karus Endoscopy Center (Medical Director) 2008-Present
(Fonnally Gastroenterology & Surgery Center of Arkansas,
Little Rock

LICENSURE: State or Arkansas, 1979

ACADEMIC APPOINTMENTS: University or Arkansas for medical Sciences, Little Rock
Department of Medicine: Instructor, 1982-1984
Clinical Instructor, 1985- 20??

PRESENT HOSPITAL APPOINTMENT AS GASTROENTEROLOGY CONSULTANT:

Baptist Medical Cente r, Little Rock
Baptist Rehabilitation institution, Little Rock
CHI St. Vincent Infirmary, Little Rock

EXHIBIT 1.1 OWNERSHIP TEAM BIOGRAPHIES

ALONZO D. WJLLIAMS, SR., M.D

Kanis Endoscopy Center, Little Rock (Formally Gastroenterology &
Surgery Center of Arkansas, Little Rock)

ADMINISTRATIVE RESPONSIBILITES:

Owner, Chief Executive Officer & Medical Director
Arkansas Diagnostic Center
Arkansas State Medical Board
Secretary, 1994- 2000; Member, 1985-2000, and
Re-appointed 2001-2008
Chairman, World Trade Center, Memphis, TN
Majority stockholder, Subsidiary of the World Trade
Center, Memphis, TN
Medical Director
Covenant Surgical Partners Gastroenterology Advisory Board
Member , 2014-current

PROFESSIONAL MEMBERSHIPS:

National Medical Association
American Gastroenterology Association
Pulaski County Medical Society
Arkansas Medical Society
Arkansas, Medical , Dental , Pharmaceutical Association
(AMDPA)
American College of Gastroenterology
American Society for Gastrointestinal Endoscopies

EXHIBIT 1.1 OWNERSHIP TEAM BIOGRAPHIES

Cliff Peck DVM

Promoting health and happiness to pets in our neighborhood, Cliff Peck DVM, moved to Ferndale AR in 1984. He studied business management at Texas Cedarwood Institute before transferring to the University of Arkansas in Fayetteville. After taking part in the family automotive business, and owning Cliff Peck Toyota for five years, he decided to follow his passion and lifelong dream of veterinary medicine. In 1989 Cliff began studying at the University of Central Arkansas to pick up deficiencies needed to apply to Louisiana State University in 1993 and graduated in 1997 with his doctorate in veterinary medicine.

Since 1999 Dr. Peck has owned and operated Doubletree Veterinary Clinic. He opened a second veterinary clinic, The Boulevard, in 2012. Dr. Cliff Peck is an industry expert with more than 20 years of successful experience providing a lifecycle of health to pets in the veterinary industry.

Dr. Peck has the proven ability to foster communications and relationships, while incorporating medical support, between clients and their pet. Cliff is most fulfilled when helping to restore animals back to a healthy lifestyle. His vision and ability to nurture animals through a lifetime of health and happiness is his gift and talent.

- Supporter and volunteer to Pfeifer Kiwanis Camp for inner-city children
- Current license holder with the DEA #BP6170663
- Scientific educator for Ferncliff Camp
- PRN Veterinarian for the Little Rock Municipal Zoo
- On call with the FBI hostage rescue team: Operations “Delta Blues” and “Blynd Justus”
- Advisor to MEMS SWAT team
- Volunteer at Direct Action Resource Center
- Little Rock Christian Academy – J-term mentor
- Volunteer science educational lecturer
- Instructor for Direct Action Resource Center
- Lay minister for the community

EXHIBIT 1.1 OWNERSHIP TEAM BIOGRAPHIES

D. Keith Mooney, MD

BS Chemistry

MD, Board Certified Urologist (emphasis on oncology, infertility, and prostate Cancer)

President of Arkansas Urology 12+ years (10 physicians, 165+ employees)

Adjunct Professor, UAMS (University of Arkansas for Medical Sciences, urology)

Arkansas Times - Best Doctors - urology 18+ years

Arkansas Times - Best Doctors for this decade (urology)

Arkansas Business - Best Urologist 18 + years

Most Compassionate Doctor – 3 + years

Assets

- men's health clinic
- assist with development / coordination of clinical trials
- conduct market research
- own's 645 acre farm (USDA wetlands programs)
- owns produce co (NLR and Hot Springs) see DM bio

EXHIBIT 1.1 OWNERSHIP TEAM BIOGRAPHIES

DONNA TERRELL

A personal tragedy is what drives Fox16's television news anchor Donna Terrell to seek involvement with medical marijuana in Arkansas.

In 2004 Donna's only child, Queah, was diagnosed with Stage III colon cancer at age of 27. Over the course of seven years, she battled the disease twice. Donna has often described the second bout as cancer that came back with a vengeance. But the mother and daughter remained optimistic hoping medicine and faith could help them win the fight a second time. Unfortunately, it was not meant to be.

During the last two years of Queah's life, Donna moved her daughter from Houston, Texas to Little Rock so that she could care for her. Because of cancer and its associated treatments and surgeries, Queah couldn't eat, and when she did eat she couldn't keep food down. It was eventually suggested that Queah could benefit from marijuana.

As Donna tells the story, "I don't smoke marijuana, I don't want people smoking it around me or in my home". But she was desperate and felt there was a chance her daughter could find comfort, so she allowed it in her home. Turns out, it was a positive experience for Queah. She developed an appetite, had less anxiety and her nausea was under control. Unfortunately, Donna's daughter could not continue smoking marijuana because they were unable to continuously obtain the drug. After exhausting every medical option they had, Queah was essentially skin and bones when she died on March 19, 2011. Donna has often said, "Cancer was a factor, but my daughter died from starvation. You could look at her and tell. Marijuana wouldn't have saved her, but she would have had a better quality of life".

Queah's death inspired Donna to draft a plan to help others, especially young people dealing with colon and other cancers. She was inspired by an experience her daughter had during chemotherapy treatments. Queah was introduced to yoga through a program at her hospital in Texas. Her mother remembers the phone call she received when her daughter first tried yoga and said it made her feel more at ease from the side effects of the drugs. That is the inspiration for 'Donna Terrell's Yoga Warriors Fighting Colon Cancer', a 501(c)3 nonprofit organization. Yoga Warriors is specifically designed to raise awareness and help survivors of all different kinds of cancer. Each year the organization has a community-wide, free event where hundreds of people come to learn the art of yoga, get information on leading a healthy lifestyle and becoming more aware of changes that may be happening in their bodies. Through donations, Yoga Warriors continues to successfully raise money each year to provide liquid nutritional supplements to cancer survivors needing financial assistance. It is also the brainchild and financier for free yoga classes for cancer survivors, patients and caregivers on the campus at the CARTI Cancer Center facility.

In addition to being an award winning news anchor and reporter for central Arkansas' Fox16 News at 5:30 p.m and 9 p.m, the 30-year television veteran also created a business model and launched her own company called Q-Impact, LLC. Through Q-Impact, she utilizes her skills in television news, marketing and different social media platforms. She is often asked to give

EXHIBIT 1.1 OWNERSHIP TEAM BIOGRAPHIES

motivational speeches and emcee at various community events throughout the state. Donna has also performed duties for AETN, Arkansas' Public Television Station.

Community service and volunteering are also a passion for Donna. She has served on several executive boards for nonprofit groups; the most recent include Woman and Children First Domestic Violence Facility, Arkansas' Susan G. Komen Breast Cancer Foundation and Ronald McDonald House. She has also performed duties as an Ambassador for the American Cancer Society traveling to Washington DC to speak to congressional members to help shape policies regarding cancer issues.

Throughout her broadcast career, Donna has been honored with several awards, most recently earning an Emmy Award for her work as a news anchor. She also won the National American Legion Fourth Estate Award and an Associated Press Award for her special reports on Grieving a Child. She garnered two more Emmy Awards for her work bringing light to cosmetic surgery and breast cancer issues. She has been nominated for many other Emmy Awards including a story she did involving Arkansas' Little Rock 9, a story she covered on her daughter's battle with colon cancer and for her work as an anchor. Donna also earned an Associated Press Award for her story on the controversial patients' Right To Die.

Donna has a Bachelor of Applied Arts Degree in Broadcast and Cinematic Arts from Central Michigan University. She is a member of the National Association of Television Arts and Sciences, the National Association of Black Journalists and the Little Rock Chapter of The Links, Incorporated.

EXHIBIT 1.1 OWNERSHIP TEAM BIOGRAPHIES

Donna M. Mooney, PhD

BS – Chemistry, BS - Computer Science

MS - Computer Science

PhD - Electronics and Instrumentation (primary focus - Biomedical Engineering)

Post-Doc – Department of Pediatrics (Arkansas Children's Hospital/University of Arkansas for Medical Sciences)

Career Highlights / Experience: (Design, Programming and Implementation)

- “Non-Invasive Human Fetal Heart Rate Monitor using Adaptive Signal Processing for the evaluation of Respiratory Sinus Arrhythmia”, involved NIH / NSF clinical trials
- Academic / Research appointment (UAMS - 14+ years)
- “Virtual Reality network for children with Post Traumatic Stress Disorder (PTSD) with Heart Rate Variability and EEG analysis”, involved NIH / NSF clinical trials
- “A statewide online network for CMS nurses / physicians for clinical guidelines for disabilities for Physical Therapy, Occupational Therapy, and Speech Therapy”, outcomes based appropriation of therapy (Guidelines/Policy)
- Natural Language Processing as a front-end for Medical Expert Systems (disambiguation of the English language using meta-analysis, star neighbor associations, probability analysis, and Roget's Thesaurus)
- “ARIA” - online automation software for the Institutional Review Board process (submissions, revisions, tracking, for basic science and clinical trials - UAMS)
- “Faculty Online” - online promotion and tenure program, UAMS
- Nutrition Center – childhood obesity (prevention and intervention) and on the other end of the spectrum failure to thrive
- Delta Project – underprivileged children / families in the Mississippi, Arkansas, and Louisiana Delta (prevention and interventions)
- Center for Birth Defects Prevention – outcomes-based studies
- Federal government security algorithms
- “Edaptic”, an outcomes-based Electronic Health Record (interactive guidelines, demographics, scheduling, Laboratory, ePrescribing, and Radiology interfaces, CPOE, HHS CCHIT certification process), outcomes registries
- Dynamic Web-based Patient Entry – Cinapz (ICD-9 and ICD-10, Snowmed, ...)
- Has written numerous peer reviewed articles, grants (NSF/NIH/USDA,...), editorials, professional presentations, guest lecturer, featured panelist, clinical trials, copyrights, trademarks
- Founder / CEO Secure Computing Solutions, Edaptic, and eAppSolutions, Inc

Assets / Skills

- programming 21+ conventional computer languages (C, Java, Fortran, Assembler, .net, LISP, Prolog, Mumps, ..)
- customized web (all standard programming / scripting web languages)
- databases - Filemaker, Oracle, MS SQL, My/SQL, Sybase, Informix, DB2,.....
- HL7, XML, Web Services - interface development (ePrescribing, Lab, Radiology, ADT, Scheduling, CPOE,, security hashing algorithms)
- EHR HHS CCHIT certification experience
- Guidelines, Outcome-based research, data-mining, statistical analysis
- Voice-recognition, programming / database development
- Natural Language Processing
- secure online database (tracking, reconciliation, messaging,)
- RFID, iBeacons, GeoFencing tracking

EXHIBIT 1.1 OWNERSHIP TEAM BIOGRAPHIES

- biometric authentication algorithms

Accolades

For her PhD she developed a non-invasive fetal heart-rate monitor (many of the HP monitors today employ her algorithms). She created the entire instrument from design and fabrication of the board to the assembly and programming. She used adaptive signal processing to remove the maternal cardiac complex exposing the entire fetal cardiac complex. While working on this project, she was invited to collaborate with several cardiologists at Harvard. Many NIH trials were run looking at both structural and functional outcomes in the fetus. The significance of this is that a fetus could be studied very early in the pregnancy without having to have the existing technology that required “the water to be broken” and a fetal scalp electrode applied (within 24 hours of delivery). She continued this research this research with her Post-Doc and followed up on many of these children after they were born. After her post-doc, she was offered a faculty position at The University of Arkansas for Medical Sciences in the Department of Pediatrics. The Department is a partner of Arkansas Children’s Hospital. With her background she was fortunate to work on a diversity of projects. She worked with the “brain” group doing electro-physiologic studies on abused children with PTSD. She also worked with ACHRI Nutrition Center (one of a very few with Center status in the US) on a variety of childhood obesity outcomes-based interventions and prevention studies, as well as, failure-to-thrive children.

Over the course of her career, Dr. Mooney is fortunate to be part of an elite programmer group. She collaborates with many colleagues around the world and has been invited by several large EHR companies to participate in talks about the future and how technology can influence medicine. She has been invited to be a part of “beta” test groups for software / hardware / device certifications.

She specializes in integration and is working with several entities on new integration/ interface standards. She works with all type of groups to take data from multiple sources and make it useful and improve workflow efficiencies. “Connecting the dots” Dr. Mooney utilizes the many tools at her disposal to seamlessly integrate with other systems (from single users to Enterprise).

Regulated Industry Experience

Agriculture or Horticulture

Dr. Mooney’s family runs a large produce company in Little Rock and Hot Springs. Regulations and certifications are abundant in this arena as it all deals with “Food Safety”. A requirement in this area is you must be able to track exactly where the food came from as well as where it’s current location is in the food chain. Because of “food-safety”, 24-hour surveillance is a big part of the check list and tracking algorithms. This controlled “Farm to Table” inventory control and tracking is very similar to the requirements for “Stem to Sale”. In addition to health department regulations, the FDA and USDA make frequent unannounced visits/audits. One of the main certifications from the USDA is Good Agricultural Practices (GAP) which is made up of seven divisions in the food chain. The bottom three deal with the farmers, the top 2 are comprised of grocery stores, etc. The produce company overlaps both of these groups (middle 4 levels). They deal with the local farmers (who have specialty and row-crop certifications) on a daily basis as well as the

EXHIBIT 1.1 OWNERSHIP TEAM BIOGRAPHIES

industrial food brokers. They support “Arkansas Grown” every day and have a statewide distribution network (which has another set of regulations).

Medicine

In addition to the large medical-related regulatory body of work listed above, Dr. Mooney develops integrated solutions which move data bi-directionally between an application and the patient’s Electronic Health Record (EHR). She has also written complex certified medication prescription modules for Surescripts (the national prescription drug repository) and EHRs.

She is a partner in Bespoke Health Media, LLC and has developed a patient education application “MDspoke” which allows for targeted guidelines-based patient education (procedure, test, and medication education) by their physician. It also provides common FAQs and Informed Consent that become a part of the patient’s medical record.

Community Outreach

Dr. Mooney’s passion is with The Twentieth Century Club. She participated in the club’s building and fundraising efforts for the Hope Lodge. The lodge has 22 suites for cancer patients and their caregivers and serves as their home away from home. Club members offer support by serving meals, visiting with the guests, having themed fun nights, and providing a place where support groups can aid in their health and well-being while receiving treatments in Little Rock.

EXHIBIT 1.1 OWNERSHIP TEAM BIOGRAPHIES

Joseph Courtright

USA Drug

Mr. Courtright was promoted in 2006 to his most recent position as President and CEO of USA Drug Stores. USA Drug was headquartered in Pine Bluff, Arkansas with corporate offices in Little Rock, AR. In 2012 USA Drug operated 132 corporate locations and 157 total pharmacy locations in eight states. In addition to USA Drug, the stores operated under the banners Super D Drugs, Med-X Drugs, Drug Warehouse and May's Drug. It was the fourth largest retail pharmacy chain in the U.S. with 4,000 employees and revenue in excess of \$825 million. The chain included compounding pharmacies.

Some highlights during Courtright's tenure include the following:

- 71 retail pharmacy acquisitions.
- 2010 - Orchestrated the sale of the Memphis, TN market of USA Drug and Ike's Deep Discount to Walgreens.
- 2010 - Purchased remaining shares of USA Drug owned by private equity firm Stephens, Inc. making USA Drug the largest privately held pharmacy chain in the US. Total valuation at purchase of \$214M.
- 2012 - Orchestrated the sale of USA Drug and seven subsidiary companies to Walgreens with a total purchase price in excess of \$550 million. This represented a gain of \$453M and an IRR of 30.3% during Mr. Courtright's leadership.
- Operated **highly regulated industries** with multi state licenses in pharmacy, DEA controlled substance distribution, alcohol, tobacco and cigarettes, underground gas, Eggs, Western Union, EBF (food stamps), Class VII Liquified Petroleum, Food and Lottery. Total licenses in excess of 1,000.

SAJ Distributors

In addition, under Mr. Courtright's leadership, USA Drug owned and operated SAJ Distributors in Pine Bluff, AR. SAJ distributes food, general merchandise, HBC and ethnic products as well as legend pharmaceuticals and DEA **regulated** controlled substances. Some points include:

- State wholesale distribution licenses in 27 states.
- 24,900 active unique Items warehoused for distribution supplying 1,000's of retail customers including 106 in Arkansas.
- 2,441 Legend (prescription) drugs and controlled substances actively distributing to 457 pharmacies.
- Both the main warehouse and generic pharmaceutical warehouse were highly controlled, restricted access as well as monitored by 24-hour live and electronic security surveillance.
-

Prior to becoming CEO of USA Drug, Courtright began his pharmacy career 1989 as a pharmacist for May's Drug Stores, Inc a 39 store pharmacy chain located in Tulsa, OK. Courtright became the Senior Vice President of Pharmacy and Information Technology. During this time period, the company expanded by 70 %. In 2003, May's Drug Stores was named Pharmacy Chain of the Year by Drug Topics magazine.

Additionally, in 2003, he designed and developed the first multi-location, multi-state, on-line **secure inventory tracking system** for pseudoephedrine and methamphetamine precursor products. He also served as the HIPAA **Security** officer.

KPH Healthcare

Current Member of the Board of Directors for KPH Healthcare located in Syracuse, NY. KPH is a national provider of pharmaceutical and health care services with complementary businesses in both the retail and commercial segments of the industry. The company is comprised of four divisions: Kinney

EXHIBIT 1.1 OWNERSHIP TEAM BIOGRAPHIES

Drugs, a chain of 100 full-service drug stores located throughout New York and Vermont; Health Direct Institutional Pharmacy Services, that services long-term care and alternative care needs; ProAct, Inc., a pharmacy benefit management company with sales offices throughout the country and a mail order pharmacy; and Noble Health Services, a specialty pharmacy that dispenses medications used to treat complex and chronic diseases. KPH has annual revenue over \$1 billion and 3,000 employees.

Associated Steel Group, LLC

Current Member Board of Directors and owner of Associated Steel Group “ASG”. ASG is a steel building **Manufacturing** holding company with revenues of \$125 million. The company owns Alliance Steel Inc. in Oklahoma City as well as ACI Building Systems located in Batesville, MS. The company previously owned AIM Metals, LLC located in Columbus, Ga. All three locations are solely focused on **manufacturing** of steel building and roofing products.

NACDS

Previous member of the Board of Directors of the National Association of Chain Drug Stores (NACDS). NACDS represents traditional drug stores, supermarkets and mass merchants totaling 40,000 pharmacies, 3.2 million employees including 178,000 pharmacies.

CDC

Former member of the Board of Directors Chain Drug Consortium (CDC). A consortium of eight of the largest regional retail pharmacy chains in the U.S. and Puerto Rico.

Data-Rx

Previous member of the Board of Directors of Data-Rx. DataRx provides Pharmacy Benefit Management solutions, Health Saving programs, and Pharmacy Technology services for insurance brokers, third-party administrators, employers, municipalities, HMOs, hospitals and pharmacy groups throughout the United States.

Our House

Current member of the Board of Directors for Our House, a charitable organization located in Little Rock, AR. Our House empowers homeless and near-homeless families and individuals to succeed in the workforce, in school, and in life through hard work, wise decision-making, and active participation in the community. It consists of two shelters and numerous outreach programs.

In 2017, Mr. Courtright became the sixth ever recipient of the Distinguished Service Award from the University of Kansas, School of Pharmacy.

Current Licensed Pharmacist in Kansas, Missouri, Oklahoma and Arkansas.

Current training in Fraud Waste and Abuse as well as Security Awareness.

EXHIBIT 1.1 OWNERSHIP TEAM BIOGRAPHIES

Kathryne Deane Peck

When children experience adult diseases and comorbidities at such a young age in their lifespan, it is not uncommon for their lives to spiral out of control. My great passion is helping children regain optimal health and successful weight management. Deane Peck's expertise lies in educational, behavioral, development and publications of childhood obesity interventions to decrease and prevent the growing disease. She earned her certifications for Child and Adolescent Weight Management and Adult Weight Management Training from the Academy of Nutrition and Dietetics.

Deane served as the grant manager for Arkansas Children's Hospital over the Fitness Clinic an outreach program for obese children from 2001-2008. She has presented at local, regional and national conferences on topics related to bariatric surgery, prevention and treatment of childhood and adolescent obesity. She is a published journal author and Co-author of "Handbook of Obesity Intervention for the Lifespan". Deane and her work with childhood obesity has been featured in Peoples magazine and in the documentary "RX for Survival: A Global Health Challenge", produced by WGBH, Bill and Melinda Gates Foundation and Vulcan production and narrated by Brad Pitt.

She is an experienced and active member of Solutions Institutional Review Board for research and evaluation. She is the CEO of Weight2Go, DBA Portionsizematters, since 2010. She is the creator and owner of the professional services patent U.S. No. D659,479. The patent is representative of the kid's portion plate, that is Trademarked (Reg. No.4,251,901), and sold on her website, Portionsizematters.com.

She holds a masters degree in Nutrition and Dietetics from the University of Central Arkansas and is licensed by the state of Arkansas to practice dietetics. Deane Peck MS, RD, LDN

EXHIBIT 1.1 OWNERSHIP TEAM BIOGRAPHIES

Dr. Kelli Schlesinger

Dr. Kelli Schlesinger offers specialized training in diagnosing, treating, and managing disorders of the brain and nervous system with an emphasis on patient comfort and care. My special interests are neuromuscular disease and headache

Residency

University of Arkansas for Medical Sciences
Department of Neurology

Medical Degree

University of Arkansas for Medical Sciences
Little Rock, AR

Board Certified with American Board of Psychiatry and Neurology

Honors

Excellence in Patient Care 2008

Chief Resident, 2011 – 2012

Jess R Nickols Foundation Outstanding Resident Award 2012

Outstanding Chief Resident Leadership Award 2012

Memberships

American Medical Association

American Academy of Neurology

American Association of Neuromuscular and Electrodiagnostic Medicine

American Headache Society

- Acupuncture training with Harvard. Provided non pharmacologic pain management options for patients who experience painful neurologic conditions.
- Gave Presentation on limb girdle muscular dystrophy at Carrell Krusen neuromuscular symposium in Dallas, TX 2012
- Currently resides on the board and as well as volunteers for the ALS in Wonderland Foundation and assists with the planning stages in hopes to open the first 24hr care center/home for ALS patients.
- Volunteered in teaching medical students during their neurology rotations (with the motivation that more will consider a career in neurology), has also given lectures at UAMS all on volunteer basis.

EXHIBIT 1.1 OWNERSHIP TEAM BIOGRAPHIES

- Volunteered in the UAMS and MDA (muscular dystrophy association) ALS clinic which occurs on Mondays.
- Have Volunteered in and we help sponsor Paul Dunn Memorial Golf Classic Tournament --- raises money for ALS research

*I had a first cousin die of motor neuron disease at the age of 8yrs old (called spinal muscular atrophy which is very similar to ALS) which is why motor neuron disease is a very important cause.

Additional References

<http://www.legacyneuro.com/>

EXHIBIT 1.1 OWNERSHIP TEAM BIOGRAPHIES

Robert DeBin

Robert DeBin was born and raised in the Natural State. He attended high school at Little Rock Christian Academy, and after graduating in 2007 he went on to pursue his bachelor's degree at the University of Arkansas at Fayetteville. There he received a bachelor's degree in Entrepreneurship and Information Systems from the Walton School of Business. He started caring for plants at an early age working for his father's landscape business from the time he was eight years old to the time he graduated from college. While at the University of Arkansas, Robert also received a Graduate Certificate in Enterprise Systems with a concentration in SAP Enterprise Resource Planning. Enterprise Resource Planning (ERP) Systems are used by almost all Fortune 500 companies and provide an integrated and continuously updated view of core business processes using common databases maintained by a database management system. At the beginning of his senior year of college, Robert accepted an internship with Agile Hub, a software startup that designs ERP solutions to foodservice distribution companies.

ERP systems track business resources—cash, raw materials, production capacity—and the status of business commitments: orders, purchase orders, and payroll. The applications that make up the system share data across various departments (manufacturing, purchasing, sales, accounting, etc.) that provide the data. ERP facilitates information flow between all business functions and manages connections to outside stakeholders. ERP systems give real time views of data that enable companies to address concerns proactively, drive improvements, and help to ensure compliance.

After graduating from college in 2011, while still interning at Agile Hub, Robert saw the need for a better solution for restaurant software systems. After some research, Robert decided to become a licensed distributor for the first iPad point of sale system designed for restaurants. In February 2013 Robert formed RockIT City Solutions, DBA CLU Solutions.

CLU Solutions paired the growing point of sale business with networking, audio/video solutions and payment processing. CLU joined an Independent Sales Office for a merchant services provider and began offering customers affordable payment processing services with the options to integrate into the point of sale. Robert became licensed with the Payment Card Industry (PCI) Security Standards Council (SSC) as Qualified Integrator and Reseller (QIR). QIRs are authorized to implement, configure, and/or support validated Payment Application Data Security Standard (PA-DSS) Payment Applications on behalf of merchants or service providers for purposes of performing Qualified Installations as part of the QIR Program. The quality, reliability, and consistency of a QIR Company's work provide confidence that the Payment Application has been implemented in a manner that supports the Customer's PCI DSS compliance.

In April 2015, Robert partnered with a group out of Louisiana and began offering iPad based retail. In January of 2016, CLU began offering IT consulting services to cannabis industry in Colorado. CLU has worked with medical marijuana point of sale providers, as well as advised dispensary operators and cannabis cultivators to help streamline their IT practices. While working in Colorado, Robert completed training for (and facilitated by) Metrc, the first all regulatory solution for cannabis. Metrc was deployed in December 2013 for the State of

EXHIBIT 1.1 OWNERSHIP TEAM BIOGRAPHIES

Colorado's Marijuana Enforcement Division. Metrc supports marijuana regulations with technology to prevent and monitor drug diversions. To date, the system has registered over 20,000 users and tracked well over 5,000,000 plants and 3,800,000 packages. A Brookings Institute report on the implementation in Colorado states, "In many ways, the system is the backbone of Colorado's regulatory structure governing legalized marijuana." -John Hudak, Brookings Institute, July 31, 2014.

Completed Metrc training:

Advanced OPC/RMC (cultivation Metrc compliance), Advanced MIP/RMPMF (infused product Metrc compliance), Testing Only Metrc Training (testing process, how it works, and how to test properly), Advanced MMC/RMS (dispensary operation Metrc compliance).

Since November 2016, Robert has been traveling between Little Rock and Denver, actively receiving training in medical cannabis cultivation with licensed producers in Denver. He holds an occupational support badge with the State of Colorado's Marijuana Enforcement Division. Lic #: M57977.

CLU Solutions now operates in four states, servicing 60+ clients. Robert has six years of experience configuring and implementing point of sale and inventory tracking systems for restaurants and retail stores. These solutions maintain real-time view of available inventory, and utilize matrix inventory to proactively restock inventory to maintain ideal levels. Robert's deep understanding of point of sale and inventory tracking combined with his experience and training in seed to sale tracking software for medical marijuana will be a valuable resource for NSM, by helping to establish best practices for compliance related to using whichever software platform the ABC chooses.

Enrolled in the Graduate School's Executive MBA Program at the University of Arkansas Little Rock.

NESA
Eagle Scout

EXHIBIT 1.1 OWNERSHIP TEAM BIOGRAPHIES

Scott Schlesinger MD FACS

Dr. Schlesinger is a lifelong Arkansan. He was born in Little Rock and lived in Hot Springs from the early 1960's until 1978. He then attended UA from 1978-82 and UAMS 1982-86. He has been in practice in Neurosurgery in Little Rock for 25 years. Dr. Schlesinger is a nationally recognized neurosurgeon who founded Legacy Spine & Neurological Specialists. The group is a multidisciplinary practice of neurology and neurosurgery specialists that diagnose and treat acute and chronic spine pain, Alzheimer's and other forms of dementia, ALS, severe spinal arthritis, Tourette's, Seizure disorders, Severe muscle spasm disorders including Torticollis and other surgical and medical disorders of the brain and spine. Their treatments include Botox injections, spinal injections for intractable acute and chronic spinal and nerve pain, spinal cord stimulators and spinal and brain surgery procedures for numerous disorders of pain and other neurological disorders.

He founded and is the Medical Director and CEO of the very successful Ambulatory Surgery Center- Legacy Surgery Center. He is the co-developer of one of today's most advanced minimally invasive spine operations- the MIG-LIF Procedure. Since 1992, Dr. Schlesinger has been integral in the national and international development of outpatient and minimally invasive spine surgery techniques. He also specializes in Trigeminal Neuralgia. Trigeminal neuralgia, also known as tic douloureux, prosopalgia or the "suicide disease" is a chronic intractable cranial nerve pain disorder described in the medical literature as "the most excruciating pain known to humanity".

The ambulatory surgery center, Legacy Surgery Center, is a 24 hour a day, 365 day a year business that manages numerous controlled substances including narcotics, benzodiazepines and anesthetic agents and requires full time oversight, management and security for such. His practice and surgery center employs and manages approximately 50 full time employees under the Center of Medicare Services (CMS) highly regulated federal "Conditions of Coverage" rules and treats approximately 3000 patients a year. They are responsible for extensive compliance programs and undergo repeated state and federal reviews including credentialing from the Department of Health and CMS every 2-4 years. He is responsible for extensive secure inventory tracking and control of medical supplies and medications including controlled substances at the surgical center. His business responsibilities as the CEO and CMO (Chief Medical Officer) at Legacy Surgery Center includes yearly budget and business planning and financial oversight that have to be submitted to state and federal agencies as part of accreditation and re-accreditation with the Arkansas Department of Health and CMS. His management experience with the Legacy Spine and Neurological Specialists' medical practice as well as the ASC also involves a highly regulated Compliance Program.

He has been actively involved in legislative affairs in Arkansas including his instrumental role in the expansion of access to care for Medicaid patients to ASC care via Act 1352 of 2013 and 1236 of 2015. He was also actively involved with the 2017 Legislative Act 820 regarding the Prescription drug monitoring program.

Dr. Schlesinger was selected by the President of the American Association of Neurological Surgeons Dr. Hunt Batjer to serve on the organization's joint committees for the national

EXHIBIT 1.1 OWNERSHIP TEAM BIOGRAPHIES

association and as a representative for the state of Arkansas on the State Societies of Neurological Surgeons.

Dr. Schlesinger graduated as the top graduate of the Fulbright College at the University of Arkansas in 1982 with numerous honors and was actively involved in student government and leadership. He graduated from UAMS in 1986 with highest honors as well. After completing neurological surgery training at Parkland Hospital- UTSW in Dallas, Dr. Schlesinger returned to Little Rock where he has been in practice since 1992.

Dr. Schlesinger and his family's philanthropic support of the state and community have been extensive including generous educational, civic and religious donations of time and financial contributions. He has been instrumental in the support of the education of our medical students and residents benefiting generations of patients now and in the future.

Dr. Schlesinger has also been a strong supporter of the state's economic growth and development through numerous investments in various Arkansas businesses and commercial real estate. Dr. Schlesinger's family owned and operated one of the nation's most successful aluminum alloy manufacturing-recycling businesses- Arkansas Aluminum Alloys in Hot Springs for many years. His personal investments in Arkansas include the growth and production in the Arkansas timber industry.

BOARD

Board Certified by the American Board of Neurological Surgery

FELLOWSHIP

Centre Hospitalier Universitaire Vaudois,
Lausanne, Switzerland

GENERAL SURGERY INTERNSHIP

University of Texas Health Sciences Center,
Parkland Hospital, Dallas, TX

NEUROSURGERY RESIDENCY

University of Texas Health Sciences Center,
Parkland Hospital, Dallas, TX

MEDICAL DEGREE

University of Arkansas for Medical Sciences,
Little Rock, AR

VOTED

Top 10 Neurological Surgeon Specialist by Vitals
AR Times 2010 Best Neurosurgeons
Best 2014 Little Rock Surgeon
2016 Innovation Hero for the MIG-LIF Procedure
AY's 2016 Best Healthcare Professionals
Vitals 2016 Patient's Choice Award
Vitals 5-Year Honoree, Patient's Choice Award

EXHIBIT 1.1 OWNERSHIP TEAM BIOGRAPHIES

Stephen Lee LaFrance, Jr

History

Stephen is a proud, lifelong Arkansan. He was born and raised in Pine Bluff and currently resides in Little Rock. Stephen graduated from the University of Arkansas in 1993 with a degree in Finance. He began his career at USA Drug, a small drug store chain and wholesale business owned by his father. In 1994, Stephen started the company's wholesale drug division which grew to provide wholesale drug services to several thousand pharmacies in 30 states. Most recently, Stephen served as Executive Vice President of the company with responsibility for finance, accounting, real estate, and mergers and acquisitions.

USA Drug owned and operated 6 drug stores when Stephen joined the company in 1993. Beginning in 1995, Stephen developed the company's acquisition strategy to purchase and consolidate independent drug stores and small chains into the USA Drug family of companies. Since that time, Stephen has led the following chain acquisitions:

- In 1997, USA purchased a 97-store chain headquartered in Memphis, TN. The stores operate under the banners Super D Drugs and Ike's Deep Discount, and are located throughout Mississippi, Tennessee, Missouri and Arkansas.
- In 2004, USA purchased a 43-store chain headquartered in Tulsa, OK. The stores operate under the banners May's Drug and Drug Warehouse and are located in metro Tulsa and surrounding communities.
- In 2004, concurrent with the May's acquisition, USA purchased a 22-store chain also headquartered in Tulsa, OK. The stores operate under the banner Med-X Drug and Drug Mart and are all located in metro Tulsa.

After the May's and Med-X acquisitions, Stephen led the company's strategy to purchase independent pharmacies in the 6 states where USA Drug operated at the time: Arkansas, Kansas, Mississippi, Missouri, Oklahoma and Tennessee. Prior to its sale to Walgreens in September 2012, USA Drug was the 6th largest drug store chain in the United States, as well as the largest privately-owned pharmacy chain, with 157 total pharmacies.

After the sale of the family business to Walgreens, the LaFrance siblings formed a private wealth management office, Dale Capital Partners, Inc., with Stephen as a main Principal officer and owner.

In addition to his role at USA Drug, Stephen was the founder, President and CEO of 6 corporations which owned and operated 32 drug stores located in 5 states. All of these stores were separate and apart from USA Drug and operate in markets outside of the USA Drug trade territory. In the aggregate, these stores produced over \$200mm in annual revenue at the time of sale.

While orchestrating the rapid growth of USA Drug, Stephen and his brother Jason also formed LAF Bros to own and manage commercial real estate investments. Currently LAF Bros owns over 30 properties expanding into at least 7 different states.

Philanthropic/Boards:

Stephen is a founding investor and current board member of Greenwoods State Bank, which is headquartered in Lake Mills, WI. Greenwoods State Bank is a State chartered community bank and is the first community bank in the United States to specialize in lending to the independent pharmacy industry.

Stephen is the founder of and was on the board of directors for the Arkansas Junior Tennis Foundation until June 2017. The foundation was organized for charitable, educational, and fostering of national or

EXHIBIT 1.1 OWNERSHIP TEAM BIOGRAPHIES

international amateur tennis competitions for the state of Arkansas. Every year they hold an ATF Southern 16's level tennis tournament in the state of Arkansas.

Stephen and his family hosted and ran the JDRF Little Rock chapter walk for several years. In 2011, he personally lead the walk and raised \$355,000 in revenue for the Arkansas chapter that year.

While at USA Drug, Stephen and his family hosted an annual Golf Tournament to raise money for local Arkansas charities. They formed a foundation with the proceeds and Stephen was on the board until they closed it down after the sale of the USA Drug stores in 2012. The USA Drug foundation was formed in 2008 and averaged over 450k in charitable donations each year.

Stephen and his family are lifelong supporters of the Arkansas Razorback Foundation. Since Stephen graduated college they have been high level donors and supporters in trying to give back to their University of Arkansas heritage.

Application Merit Contributions:

1. Stephen was an owner and manager of STAMJA-LP WABBESEKA FARM.LLC This LLC \ owned 712 acres of farmland with 653 acres that were tillable real estate. Known as the Diantha West Farm, the crops they **cultivated and sold were rice and soybeans. Their primary customer** was Riceland Inc. located in Stuttgart, AR. This was sold in 2014.
2. Stephen is currently an owner in AG Resources II, LLC. They own farmland and **cultivate and sell soybeans and wheat** to Riceland Inc. as well. Soybeans are the main crop. Stephen has been an owner in this LLC since 2012.
3. Stephen was an owner in AG Resource, LLC that owned farmland and **cultivated and sold Wheat, Rice, and Soybeans**. He and his wife were owners from 2008 to 2011 when they sold their interest to Hamper Farm, LLC.
4. Stephen is an owner of a timber farm, Yo Eleven Enterprises, LLC. They grow trees on property in Sheridan, AR for harvesting every few years. Stephen has been an owner since 2006.
5. Prior to moving to Pine Bluff to start his first pharmacy, Stephen's father grew up farming and helping to maintain the family owned pepper farm. Knowing how important those years were to his dad, Stephen has invested in and owned several farming ventures throughout his life and continues to hold this lifestyle dear to his heart.
6. Stephen is a current owner in a steel **manufacturing** company called Associated Steel Group "ASG". ASG is a steel building **Manufacturing** holding company with revenues of \$125 million. The company owns Alliance Steel Inc. in Oklahoma City as well as ACI Building Systems located in Batesville, MS. The company previously owned AIM Metals, LLC located in Columbus, Ga. All three locations are solely focused on **manufacturing** of steel building and roofing products.

Additional References:

An article on the sale of the family pharmacy chain to Walgreens in 2012:

<http://www.wsj.com/articles/SB10001424052702304141204577508520110758742>

A link to one of the many current Real Estate funds that Stephen and his family help manage and fund.

<http://www.tempusrealty.com/>

EXHIBIT 1.1 OWNERSHIP TEAM BIOGRAPHIES

Susan D. Williams

Susan D. Williams is a native of Dumas, Arkansas. She is a former educator in the Little Rock School District from 1993-1999. Susan is a freelance interior designer and accomplished bronze sculptor. Mrs. Williams also serves as the director of special projects for Pacific Coast Management also in Little Rock, Arkansas. Mrs. Williams received her undergraduate degree from the University of Arkansas at Fayetteville, earning a Bachelor of Arts in Housing and Interior Design in 1981. Mrs. Williams is the owner of Pathology Partners Histology and Toxicology Laboratories.

Mrs. Williams founded Pathology Partners in 2008, the lab offers Anatomical and Molecular Diagnostics as well as toxicology testing, and both divisions of the lab are Clinical Laboratory Improvement (CLIA) Certified. Pathology Partners toxicology division is also College of American Pathologists (CAP) certified. In addition to her duties with Pathology Partners and Pacific Coast Management, Mrs. Williams is the founder of SUSWI, Inc., responsible for overseeing of the design and project development for over 25,000 sq. feet of healthcare real estate developments under the Pacific Coast Management umbrella.

Mrs. Williams has always been involved with numerous community organizations including Arkansas Medical Dental and Pharmaceutical Association Auxiliary, Arkansas Humanities Council, Arkansas Sculptors Guild, Parents of Central High School Little Rock, Arkansas 2006-2008, The Tidwell Dance Project Board and The Links, Incorporated.

EXHIBIT 1.1 OWNERSHIP TEAM BIOGRAPHIES

Susan D. Williams

Experience

Independent Business Owner

Pathology Partners, Little Rock, Arkansas

2008- Current

Founder of Pathology Partners

Developed operational plans and marketing strategies

Maintain client accounts by tracking data, personnel information, inspections, audits, and national, local and state policy changes

Provide management support to lab personnel and ensure adequate resources

Oversee developments and design changes for lab sites

Director of Special Projects

Pacific Coast Management, Little Rock, Arkansas

2006 - Current

Work across departments throughout the companies to identify needs and opportunities for growth and development

Developed new operational plans and new marketing strategies

Serves as the link between physicians, staff and management

Worked with marketing firms to implement new marketing strategies to promote the clinics and health care outreach

Oversee new developments and design changes for buildings and tenants

**Education and
Certifications**

University of Arkansas at Fayetteville

Bachelor of Arts in Housing and Interior Design, 1981

Internship at Cromwell Architect Firm, 1982

Arkansas Department of Education Teaching Certification, 1994

Dumas High School

Diploma, 1977

VOLUNTEER ACTIVITIES

Arkansas Baptist College

Shor/er College

Little Rock Public Schools

Arkansas Medical Dental and Pharmaceutical Association Auxiliary Member

EXHIBIT 1.1 OWNERSHIP TEAM BIOGRAPHIES

Susan D. Williams

Arkansas Humanities Council

Arkansas Sculptors Guild

Parents of Central High School Little Rock, Arkansas 2006-2008

The Tidwell Dance Project Board

The Links, Incorporated

EXHIBIT 1.1 OWNERSHIP TEAM BIOGRAPHIES
Wendy Perdue LaFrance

History:

Wendy Perdue LaFrance was born and raised in Pine Bluff and currently resides in Little Rock with her husband of 24 years, Stephen LaFrance, Jr., and their daughter. She graduated from the University of Arkansas with a degree in Early Childhood Education. She taught grade school at Pine Bluff public schools for a total of nine years with the majority of time teaching at Forrest Park Elementary School from 1991 to 1997. Presently Wendy is a stay at home mom and home schools their daughter.

Philanthropic/Boards:

Wendy volunteered at Episcopal Colligate School for several years while her daughter attended school there. Being a kindergarten teacher for nine years in Pine Bluff, lead to her passion for helping teachers in her free time.

Wendy along with Stephen and their family hosted and ran the JDRF Little Rock chapter walk for several years.

Application Merit Contributions:

1. Wendy was an owner in AG Resource, LLC that owned farmland and **cultivated and sold Wheat, Rice, and Soybeans**. She and her husband were owners from 2008 to 2011 when they sold their interest to Hamper Farm, LLC.
2. Wendy also owned LaFrance Farm and Ranch, LLC from 2008 to 2015. Her LLC owned Woodruff County Farmland in Arkansas. It also cultivated and sold Wheat, Rice, and Soybeans.

Additional References:

An article on Wendy by Little Rock Soiree in 2011: <http://www.littlerocksoiree.com/post/26372/wendy-lafrance-on-why-we-walk>

EXHIBIT 1.2 - ADVISORY TEAM BIOGRAPHIES

Andrew Salini

Mr. Andrew Salini is a Princeton graduate. He has experience as a strategist and portfolio manager at EMF, a fixed income hedge fund with \$500 million AUM from 2011- 2014. Andrew also worked for 5 years as an investment banker at Deutsche Bank and later Credit Suisse. He also oversees the operations of three cannabis cultivation facilities and four dispensaries in Colorado for High Country Healing, an industry leader both in Colorado and in the United States. High Country Healing has won numerous awards for its cultivated cannabis using proven USDA organic methodologies. It known has revenues total \$10+ million between all of its cultivation and dispensary facilities. High Country Healing prides itself on being socially responsible, forward thinking with patient friendly branding. More specifically, High Country Healing has developed a color labeling program for specific chemotypes which will be used by NSM to further develop its own medicinal identification and classification program for patients in Arkansas. Andrew will be relocating to Arkansas to supervise all aspects of the production of our product. His experience includes years of founding and operating legal cannabis cultivation facilities in Colorado.

EXHIBIT 1.2 - ADVISORY TEAM BIOGRAPHIES

Harry E. (“Bud”) Cummins III

Bud Cummins is an attorney who has been licensed in good standing in the State of Arkansas since 1989. His law practice is conducted through a legal entity known as “Law Offices of Bud Cummins, PLC.”

Cummins served as a federal law clerk to a U.S. Magistrate Judge and later to the Chief U.S. District Judge for the Eastern District of Arkansas. He once served as Chief Legal Counsel to Governor Mike Huckabee, and later served as the presidentially appointed United States Attorney for the Eastern District of Arkansas from 2001 to 2006.

Much of the balance of his career has been invested in the private practice of law, specializing in compliance, internal investigations, litigation, and federal criminal defense. Cummins is rated AV Preeminent by Martindale Hubbell.

Cummins graduated from the University of Arkansas in 1981 with a degree in finance and real estate. He earned his JD from the University of Arkansas at Little Rock (now Bowen School of Law) in 1989.

EXHIBIT 1.2 - ADVISORY TEAM BIOGRAPHIES

Frank Groves, Ph.D.

Frank Groves is a member of the Board of Directors of Natural State Medicinals serving in the role of Director of Agriculture and Genetics. Frank holds a Ph.D. in Plant Breeding and Genetics from the University of Arkansas and brings to this position over twenty years experience in the field.

Frank began his career in agriculture as a researcher with the University of Arkansas in 2000 after having served six years in the Arkansas Army National Guard, including one year of active duty in Iraq during Operation Desert Storm. Frank conducted small plot research and technology transfer to growers and county extension agents across Arkansas until 2007 during which time he completed an M.S. in Agriculture with a focus on Weed Science.

While working for the University of Arkansas, Frank was awarded a Cotton Incorporated Fellowship in support of his doctoral research. He completed his Ph.D. in plant breeding and genetics in 2010. Frank then joined Monsanto Global Cotton Breeding, where he rapidly ascended to leadership and oversaw the development of a global cotton-breeding pipeline between the U.S., India and Brazil.

In 2016, Frank launched an 80-acre start-up farm focused on the development of sustainable and innovative produce farming practices in the Arkansas Delta. After finding success with these products in a local market, Frank formed Benson Creek Produce, LLC in 2017. Benson Creek Produce is a 400-acre operation that has earned regional recognition as a premium brand in the market.

Professional Contributions

Published Lead Author of two Peer Reviewed Journal Articles
Arkansas State Plant Board – Advisory Role
Arkansas Crop Protection Association – Vice President
Certified Crop Adviser 2004 – 2012

EXHIBIT 1.2 - ADVISORY TEAM BIOGRAPHIES

Josh Risley

In 2005, during his junior year studying history and philosophy at Clemson University, Josh Risley created and founded his first entrepreneurial venture, the band PictureMeFree. Within a year, PMF was signed to an independent record label out of Athens, GA and spent the next few years touring and performing original music full time. During this time, Josh set the strategic vision, managed, organized, marketed, and grew the band from an unlikely idea, into a thriving small business that provided full-time employment for 7 people, for 5 years. During these years of touring, Josh had countless opportunities to meet, converse, and learn from interesting people from all walks of life, across the United States, including some of his musical heroes, like Blues Traveler, The Marshall Tucker Band, and Eddie Money, among others. Although Josh dreamed the band would last to his retirement, due to irreconcilable differences between some members, the band/company was not able to continue and ended prematurely after 6 fast-paced, successful, and enlightening years.

Shortly after the band's end, Josh received a fortuitous opportunity to move to Colorado with a college friend who had just purchased a house in Denver and needed help paying the mortgage. Having already witnessed Colorado's rich music scene and the rapidly emerging Cannabis economy in previous years of touring, Josh jumped at the potential opportunity to be a part of them both, and he made the move to CO in late summer of 2011. Within a few months of moving to CO, Josh was working 5 part-time jobs that were challenging, enriching, and rewarding: (1.) Teaching vocal lessons at the Boulder School of Rock (2.) Landscaping for internationally renowned architect David Levitt (3.) Trimming Cannabis all over the state of CO for Colorado Harvest Company (4.) Making Cannabis concentrates for the two largest medical dispensaries in Colorado as an independent contractor (5.) Solo operating 2 medium sized Cannabis gardens for a Colorado medical caregiver with 20 patients.

In December 2013, Josh was hired by the School of Rock corporation to be the Boulder location's full time general manger. The Boulder school had not been profitable in the 5 years since its opening. Within two months of Josh taking over the GM position, the Boulder school achieved 5-figure net monthly profitability, and after six subsequent months of steady growth, in July 2014, Josh was hired to also manage the Broomfield School of Rock.

In June of 2015, the owner of the aforementioned School of Rock franchises asked Josh to start a Cannabis company in exchange for equity and full operational and administrative control of the proposed company as its CEO. Josh accepted this opportunity and transitioned to a consulting position with the schools of rock while he began building the team and brand of Cannabis Maximus from "just another Cannabis idea," to a profitable, well regarded, and licensed Cannabis concentrate manufacturer.

During this time, Josh was responsible for creating the brand, hiring all personnel, reading, learning, and communicating the Colorado Retail Marijuana Code to employees, partners, and clients, interfacing with government representatives to ensure the compliance of the laboratory's construction and the compliance of all laboratory and product SOP's, setting the strategic vision for Cannabis Maximus, setting management goals, supplying the organizational tools to facilitate team success, acquiring a Colorado Marijuana Enforcement Division retail manufacturing license, and acquiring all applicable building and business permits for a Cannabis concentrates manufacturing facility in Aurora, Colorado.

EXHIBIT 1.2 - ADVISORY TEAM BIOGRAPHIES

Josh Risley

The laboratory Josh and his team designed and ultimately built meets FDA clinical standards, as well as achieving the pinnacle of OSHA safety compliance (Class I Division I) to ensure it will withstand the ever tightening regulations around light hydrocarbon Cannabis extractions, no matter how restrictive they may become. Throughout this process Josh has done copious amounts of research on the science, politics, safety, and business of Cannabis concentrates, including extensive communication with leading industrial hygienists, engineers, architects, chemists, lawyers, local and state police, and local and state fire departments, none of which had ever built a Class 1 Division 1 Cannabis extraction facility before Cannabis Maximus's.

Because no other Cannabis extraction laboratories in Colorado, or anywhere else that we are aware of, had previously been built to this standard, Cannabis Maximus helped pioneer the process for true Class I Division I Cannabis extraction processing in Colorado, the United States, and ultimately the world. After successfully navigating CM through this formidable process, Josh learned how to design, construct, and operate a safe, efficient, and technologically cutting edge light hydrocarbon Cannabis extraction facility that represents Cannabis extraction processing in a safe, scientific, and professional manner. Cannabis Maximus's manufacturing and sales operations began with practically no budget as a new and unknown brand. Within 8 months of opening operations, Cannabis Maximus now consistently grosses between \$100,000 - \$120,000 of revenue every month, has grown from 5 to 20 employees, is sold in over 40 CO retail dispensary locations, and is recognized as one of the premier concentrate brands in Colorado.

EXHIBIT 1.2 - ADVISORY TEAM BIOGRAPHIES

Lance Huey

Lance is 53 years old and lives in Sheridan, Arkansas. He has two children, Emma (19), a sophomore at Arkansas Tech University, and Ethan (17), a junior at Sheridan High School. Lance was born and raised in northeast Arkansas where he graduated from Wynne High School in 1982. He holds a Bachelor of Science Degree (Organizational Management) from John Brown University.

Lance enlisted in the United States Marine Corps in 1983 and served for 7 years. He served overseas in Japan, Philippines and Korea. He attained the rank of Sergeant (E-5) and was honorably discharged in November 1990.

Lance was hired by the Arkansas State Police (ASP) in January of 1991 and was assigned to the Highway Patrol Division, Troop C, Blytheville, Arkansas. He patrolled Mississippi County as a Trooper for 6 years prior to being transferred to Troop K, Grant County, in 1997.

Lance was promoted by the ASP to the rank of Sergeant in 1999 and worked as the supervisor of Troop K, Post 3 for 7 years. During his tenure as a Trooper, Lance was elected to a seat on the Grant County Quorum Court where he represented the citizens of District 1 for two terms (2003 through 2006). He served on the county's budget committee and the buildings/grounds committee.

Lance was elected Sheriff of Grant County in 2006. He left the Arkansas State Police on December 31, 2006 and was sworn in as Sheriff on January 1, 2007. He was re-elected in 2008 and served as Sheriff for two terms before resigning in 2009.

While serving as Sheriff, Lance was asked to become part of the state's new Arkansas Lottery Commission which was voted into law by the citizens of Arkansas in 2008. He was hired as the very first Director of Security for the Arkansas Scholarship Lottery in July of 2009. He served in that position for 5 years until his retirement from state/county government in June 2014.

Since retiring, Lance has focused on his business, Sheridan Insulators - a company he has owned for twenty years - as the owner/operator. His company installs insulation into new/existing residential and commercial structures.

Over his career, Lance has completed over 1400 hours of police training. His accomplishments in law enforcement include his graduation from the Arkansas Law Enforcement Training Academy, Arkansas State Police Troop School (where he was elected class speaker), the Arkansas Leader's Program, and the prestigious National Sheriff's Institute (where he was voted class speaker). He has served on state committees as well as national committees, including the National Sheriff's Association's Training Committee.

In the past, Lance has served his local community as a member of the Sheridan Rotary Club and the local United Way Advisory Committee.

EXHIBIT 1.2 - ADVISORY TEAM BIOGRAPHIES

Terence Fitch

Terence Fitch has served as a member of the Board of Directors of MassRoots since 2015, a publicly traded entity that manages the premier social network for the cannabis community. As of June 2017, it had an estimated 1 million users. In the same year that he joined MassRoots' BOD, Mr. Fitch invested in and became CEO of Super Farm, LLC of Denver, Colorado, an operation that cultivates over 12,000 pounds of cannabis annually and employs over 65 persons.

Mr. Fitch is a seasoned corporate executive with over 30 years of marketing, sales, finance, manufacturing, supply chain, media, and supervisory experience gained in the highly competitive and regulated beverage industry. After obtaining his undergraduate degree in 1982 in marketing and finance from Arizona State University, Mr. Fitch began his career as a management trainee in the beverage industry. He quickly rose through the ranks to lead Coca Cola's overall operations in Arkansas. Known as a keen leader, Mr. Fitch subsequently was recruited by Coca Cola Enterprises, a marketer, producer, and distributor of Coca Cola products, where he spent 18 years in senior management, first from 1994-1998 as the Regional Vice President of Sales and Marketing of the Gulf States, then ascending for 4 years to serve as Division Vice President and General Manager, and finally for 6 years as Senior Vice President and General Manager of the Western Region, responsible for a team of 13,500 sales, strategy, marketing, operations, manufacturing, supply chain, and analytical professionals, and accountable for annual sales in excess of \$4.2 billion. Throughout his tenure in this role, Mr. Fitch was responsible for ensuring his facilities' and staff's compliance with rules regulating the production of food products, where he compiled an unblemished record of success. Following Coca Cola's acquisition of Coca Cola Enterprises, which had operated independently of Coca Cola, Coca Cola Enterprises was renamed Coca Cola Refreshments, and Mr. Fitch continued with that company for 3 years as Senior Vice President and General Manager of the Western Region. Thereafter, Mr. Fitch elected to begin a new chapter in his career, departing Coca Cola Refreshments to found Drink Teck, LLC in 2013, where he has served as its Chief Executive Officer since that time. Drink Teck LLC is a functional beverage company that uses liposome technology to cost-effectively formulate drinks for the consumer health and wellness sector.

Throughout his career, Mr. Fitch has shown the highest regard for the operational and ethical responsibilities that come with leading organizations. The latter was instilled in him in his early years as he rose to the rank of Eagle Scout within the Boy Scouts of America, and he has proudly upheld its traditions of honesty and integrity in his business life. Mr. Fitch has also continued the Boy Scouts' commitment to community service, serving as a member of the Board of Directors of the Harold Pump Foundation, which raised over \$9 million in nine years for cancer research as well as helped develop a free mammogram program for underprivileged inner-city women, of C-5 Youth Foundations, which raised over \$1 million annually (for a total in excess of \$15 million) to mentor and develop first-generation, college-bound teens from the inner city, including sending over 1,000 teens to summer camp for 3 months of leadership training, of the USC Food Management Council, where Mr. Fitch was integrally involved in developing the curriculum for food management courses at USC principally focused in Six Sigma training, and of the Coca Cola Scholars Foundation, which offers college scholarships to exceptional high school students dedicated to leadership, service, and action that positively affects others.

Mr. Fitch's extensive experience operating in the highly regulated industry of beverage manufacturing, where because of the ingestible nature of the products the utmost care must be taken to ensure consistency, quality, and safety is achieved each and every day with respect to every detail of every product, ideally qualifies him to lead this company devoted to the cultivation, growth, and sale of medicinal marijuana. Both endeavors require the leadership, compliance with and respect for the governing bodies and regulations, and integrity that have been hallmarks of Mr. Fitch's business career.

Exhibit 1.3

NATURAL STATE MEDICINAL EXHIBIT 1.3 ORGANIZATIONAL CHART

T. Fitch | August 31, 2017

Referenced From Sec E, Page Schedule 1

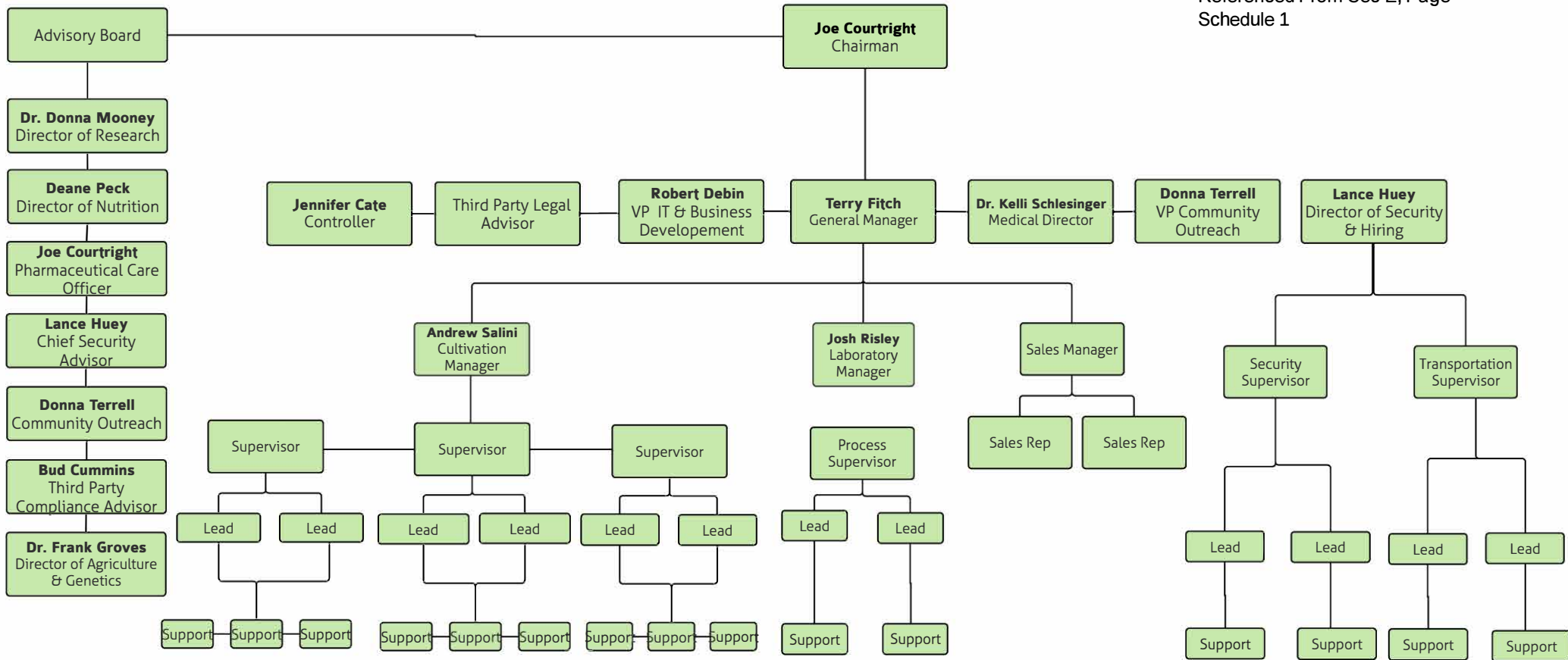

NATURAL STATE MEDICINAL - BOARD OF DIRECTORS

T. Fitch | August 31, 2017
Referenced From Sec E, Page 10
Schedule 1

Exhibit 1.3

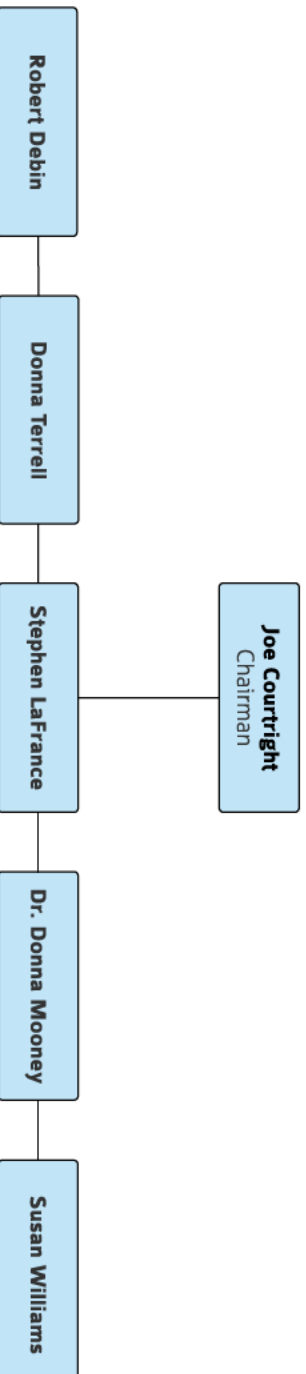

NATURAL STATE MEDICINAL - MEDICAL BOARD OF DIRECTORS

Exhibit 1.3

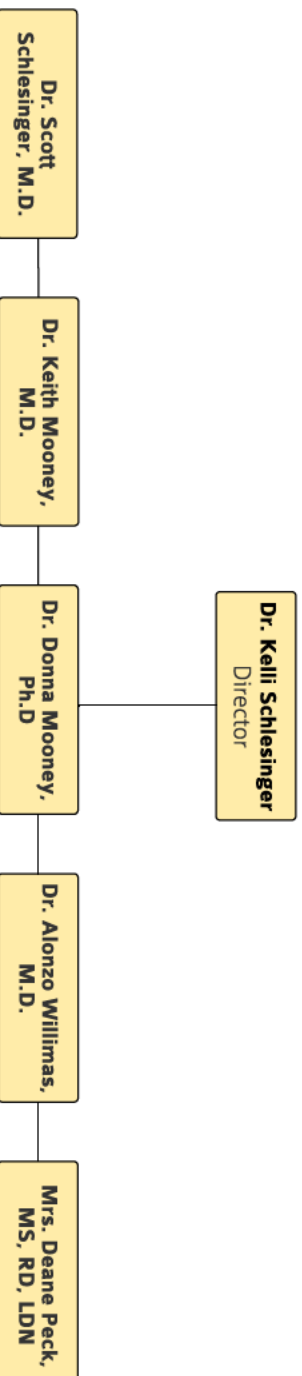

Referenced From Sec E, Page 10
Schedule 1

EXHIBIT 2.1 NSM PLOT PLAN

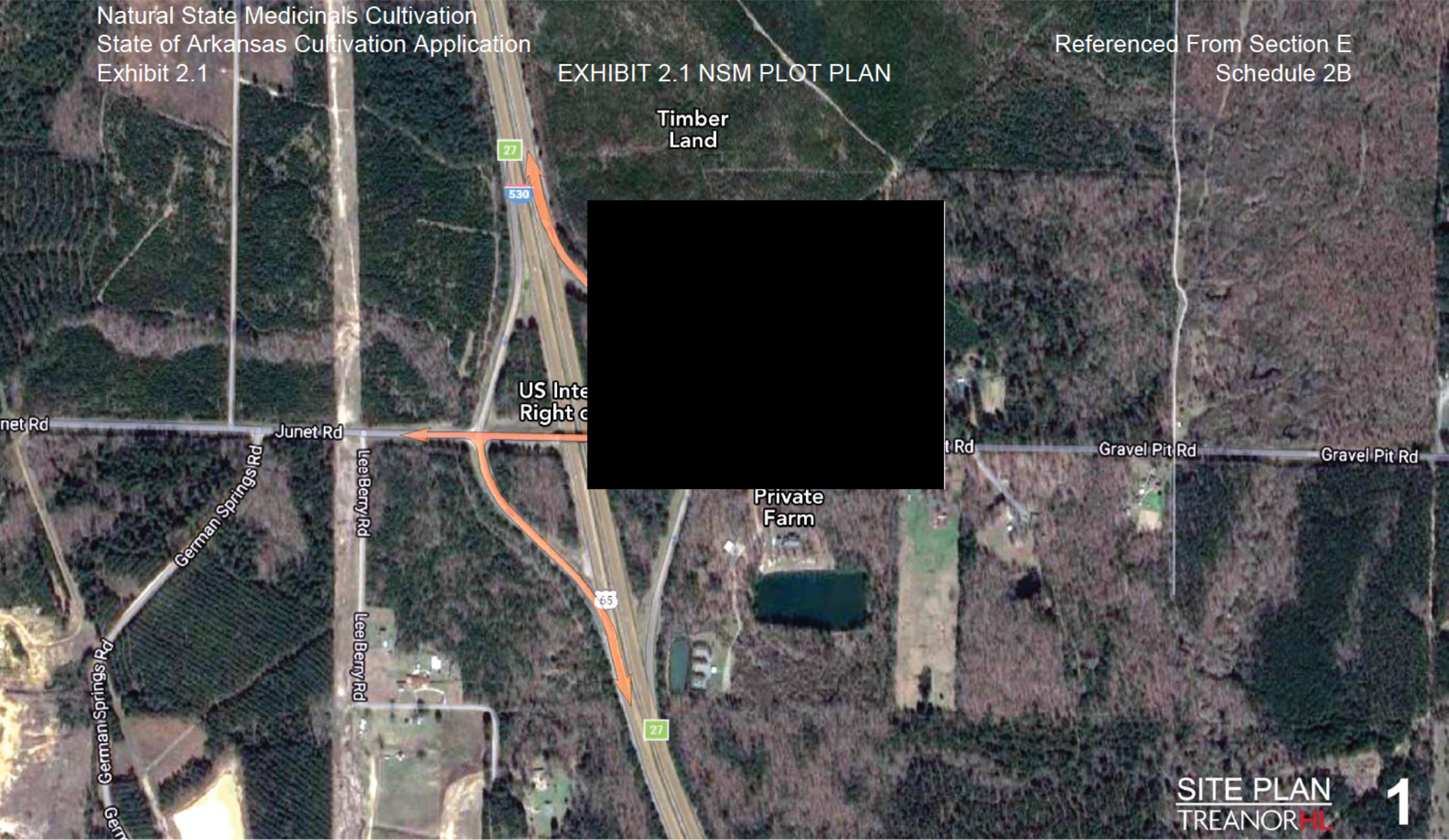



GERALD ROBINSON
SHERIFF OF JEFFERSON COUNTY
P.O. BOX 7837
PINE BLUFF, ARKANSAS 71611

CHIEF DEPUTY, Stanley James
OPERATIONS COMMANDER, Major Lafayette Woods, Jr.
JAIL ADMINISTRATOR, Greg Bolin

ADMINISTRATIVE OFFICE: 870-541-5351 • FAX 870-541-5348
INVESTIGATIONS: 870-541-5496
PATROL: 870-541-5376
WARRANTS/CIVIL PROCESS: 870-541-5349
DUB BRASSELL DETENTION CENTER: 870-541-4620
website: www.jeffcoso.org



9-13-2017

Dear Members of the Arkansas Medical Marijuana Committee,

I am writing regarding NSMC-OPCO, LLC dba Natural State Medicinals. Natural State Medicinals is applying to open and operate a medical marijuana cultivation facility in Jefferson County. The site of the proposed facility is in Jefferson County.

The purpose of this letter is to inform the committee of my trust and confidence in Lance Huey, the Director of Security for Natural State Medicinals. I have known Mr. Huey for years; he is the former Sheriff of Grant and the former Director of Security for the Arkansas Lottery Commission. I feel that Lance understands the issues any citizen of Arkansas might have with the need for proper security of a marijuana cultivation facility. I also know that he is aware of the issue which could arise for me as the Sheriff of Jefferson County.

I am confident in Mr. Huey's ability to ensure the safety of the citizens of Jefferson County and to abide by state law, as well as the rules of the Medical Marijuana Committee.

Sheriff Robinson

9-13-2017

Dear Members of the Arkansas Medical Marijuana Committee,

I am writing regarding NSMC-OPCO, LLC dba Natural State Medicinals. Natural State Medicinals is applying to open and operate a medical marijuana cultivation facility in Jefferson County. The property is in the Hardin Fire District.

Although I do not agree with legalized marijuana in any form, I have confidence in the NSM group. I have met with representatives of NSM including the Director of Security, Lance Huey, and they understand the requirements for the Hardin fire district. I do believe they will ensure the facility complies with the rules and regulations concerning water supply. They understand that the Hardin fire district requires a water supply of 250 gallons per minute.

I am confident they will operate in a manner that will protect the citizens of Jefferson County.



Chief Larry W. Smith

Hardin Fire Department
203 Todd Lynn Drive
Pine Bluff, AR 71602

NATURAL STATE MEDICINAL EXHIBIT 3.4 ORGANIZATIONAL CHART

Exhibit 3.4

Referenced From Sec E Schedule 3

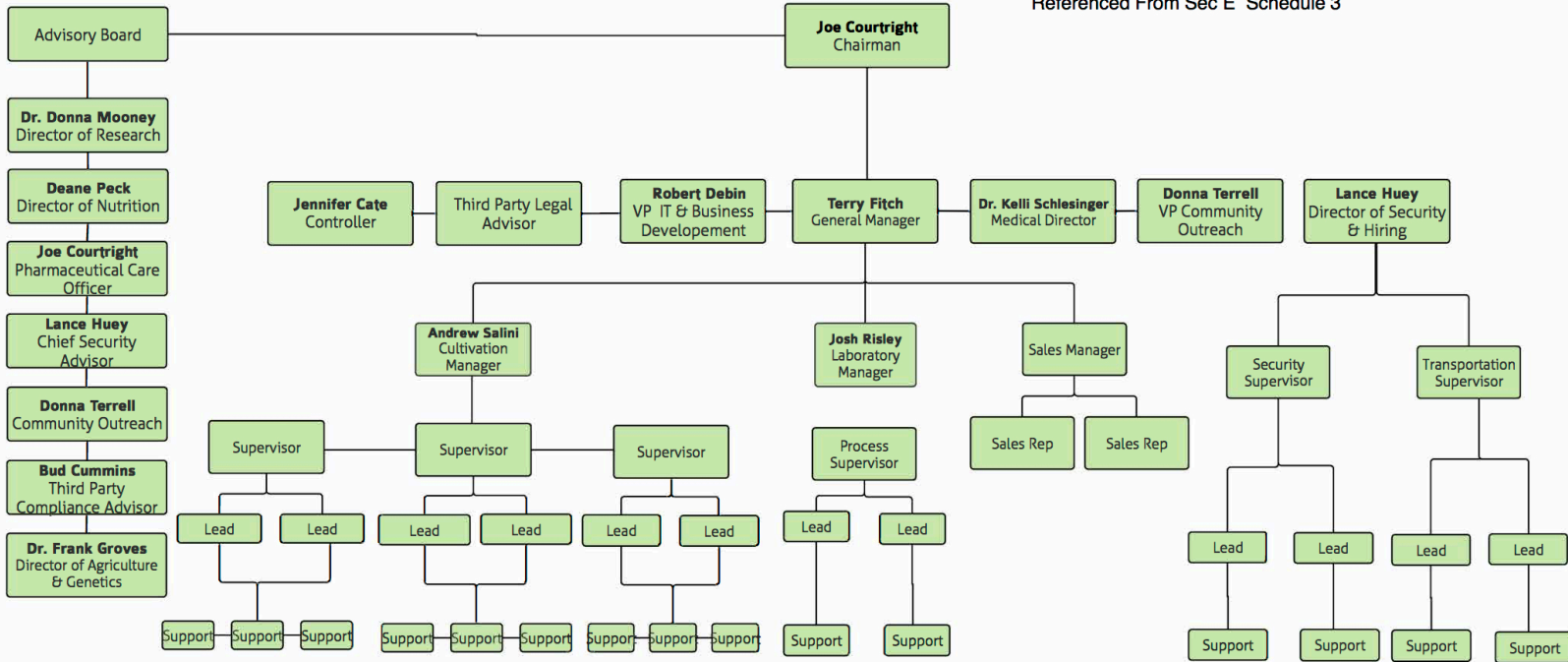

Referenced From Sec E,
Schedule 3

Exhibit 3.4

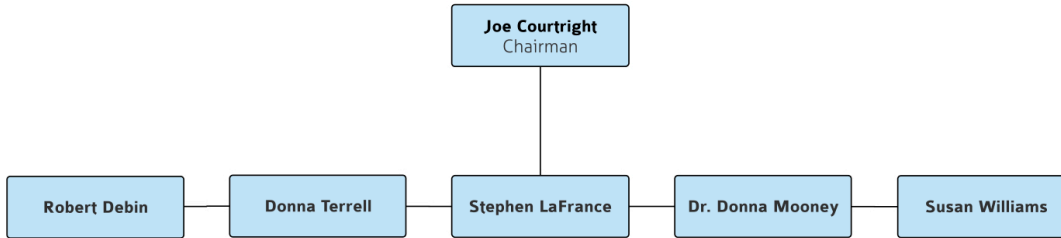

Exhibit 3.4

Referenced From Sec E,
Schedule 3

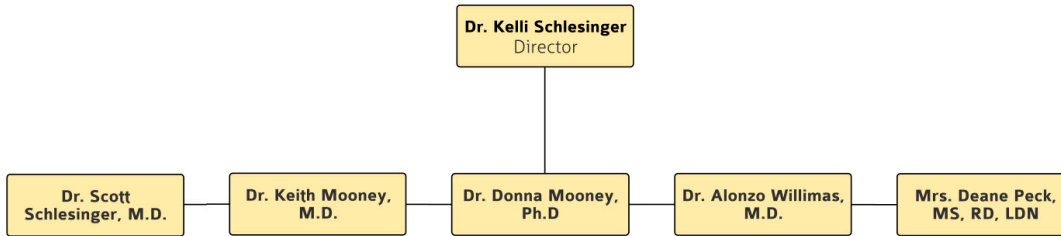

EXHIBIT 3.9 NSM ADDITIONAL HIRING CRITERIA

In order to be hired by NSM, all staff must be at least twenty-one (21) years of age and pass a recurring background check and reference check. Each staff member will provide proof of eligibility to work in the United States. Anyone whose criminal history check causes the individual to be unfit will not be hired, or will be let go (if a recurring background check identifies any current employee of having criminal activity). Only individuals who are highly qualified to perform their prospective job responsibilities are eligible for employment. The Human Resources Manager will ensure all employees meet required qualifications, experience, background, and educational credentials to carry out the duties of their assigned job. In accordance with RR 19.2, NSM will provide a prospective employee with a completed Notice of Intent to Hire form for submission to the Division. The prospective employee will not perform any duties until their Registry Identification Card has been issued by the Division.

Within 90 days of starting work for our facility, every employees will be required to take and pass the two-hour training course developed and administered by the Arkansas Department of Health. Employees who have not completed the required training within the initial 90-day period of employment will not be eligible to work until training has been successfully completed. As per RR 8.2, any employee, supervisor, or agent employed must have a current Registry Identification Card issued by the Arkansas Alcoholic Beverage Control Division on their person at all times while at the NSM cultivation facility.

EXHIBIT 3.10 STAFFING STRUCTURE

EXHIBIT 3.10 NSM STAFFING REQUIREMENTS

General Manager- The General Manager will work with the Board of Directors, the Business Advisory Board, and the Medical Advisory Board to provide leadership in achieving NSM's vision, mission, strategy, and annual goals. The General Manager will work with and oversee NSM's personnel to grow the company, strengthen it, and ensure its continued sustainability. The General Manager will represent NSM as required, including attendance of important functions, industry events, and public meetings. Additional duties will include: working closely with the Controller to prepare annual budgets, complete risk analysis on potential investments, and advise the Board of Directors with regard to investment risk and return; working closely with the General Manager and Human Resources Manager regarding hiring practices, payroll and benefit disbursement; overseeing quality control throughout the company; and establishing goals for each department in partnership with the General Manager.

Terry Finch, General Manager - Terry is a seasoned corporate executive with over 30 years of marketing, sales, finance, manufacturing, supply chain, media, and supervisory experience in the highly-competitive and -regulated beverage industry. After obtaining his undergraduate degree in 1982 in marketing and finance from Arizona State University, Mr. Finch began his career as a management trainee in the beverage industry. He quickly rose through the ranks to lead Coca-Cola's overall operations in Arkansas. His vast experience in creating standard operating procedures (SOPs) has translated into the marijuana cultivation industry. Terry is the CEO of Super Farm, LLC, of Denver, Colorado, an operation that cultivates over 12,000 pounds of cannabis annually and employs over 65 people. Given his experience in both highly-regulated industries, he understands the utmost care must be taken to ensure consistency, quality, and safety each and every day with every product. His experience ideally qualifies him to lead this company as he is devoted to the cultivation, growth, and sale of medicinal marijuana. Throughout his career, Mr. Finch has shown the highest regard for operational and ethical responsibilities with leading organizations. He has experience in leadership and compliance; respect for governing bodies and regulations have driven his successful business career.

Controller - The Controller will provide operational and programmatic support to NSM. The Controller will directly assist the General Manager on strategic and tactical matters as they relate to budget management, cost benefit analysis, forecasting needs, and securing of new funding. The Controller will be responsible for overseeing day-to-day financial operations such as general bookkeeping, bank statement reconciliation, payroll tasks, and accounting. Additional duties will include: working closely with General Manager and Human Resources Manager regarding payroll and benefit disbursement; preparing and analyzing NSM's accounting records, financial statements, and other financial reports to assess accuracy, completeness, and compliance to reporting and procedural standards; and analyzing business operations, trends, costs, revenues, financial commitments, and obligations to project future revenues and expenses or provide advice. Preferred experience for the Controller requires ten (10) years of progressively responsible experience for a major company or division of a large corporation, experience partnering with an executive team, a high level of written and oral communication skills, and an

EXHIBIT 3.10 STAFFING STRUCTURE

MBA in Finance, Certified Public Accountant (CPA), or Certified Management Accountant (CMA) designations.

Medical Director - The Medical Director is an owner who will assist with developing procedures and processes to ensure NSM's operations are patient-focused, compliant with existing best medical practices and applicable regulations, and oversee development of training materials for employees. The Medical Director will work with the Medical Advisory Board and Business Advisory Board to develop patient and physician outreach and programming at NSM's Patient Resource Center, including patient education, substance abuse assistance, a referral program to other wellness services, and patient consultation protocols. The Medical Director, with input from the Medical Advisory Board, will also advise NSM on medicinally-appropriate product offerings and production methods.

Dr. Kelli Schlesinger, Owner, Medical Director - Dr. Schlesinger was born in Springdale, and attended the University of Arkansas. She earned her Medical Degree in Neurology, and offers specialized training in diagnosing, treating, and managing brain and nervous system disorders with an emphasis on patient comfort and care. Her special interests include neuromuscular disease and headache. She holds honors such as Excellence in Patient Care (2008), and Chief Resident in Neurology. She is currently a member of the American Medical Association (AMA), American Academy of Neurology (AAN), American Association of Neuromuscular and Electrodiagnostic Medicine (AANEM), and American Headache Society (AHS).

Joe Courtright, P.D., R.Ph, Chairman, Owner, Chairman of Board of Directors - Joe began his pharmacy career in 1989 as a pharmacist for May's Drug Stores, Inc., of Tulsa, Oklahoma, ascending to Senior Vice President of Pharmacy and Information Technology. Joe is a licensed pharmacist and former President and CEO of USA Drug, the largest privately-held pharmacy chain in the U. S., headquartered in Pine Bluff, Arkansas. Under his tenure, he oversaw 153 pharmacies, 500 pharmacists, and 4,000 employees. USA Drug operated the largest wholesale pharmaceutical business in Arkansas with controlled substance distribution capability in 32 states.

Joe is a member of the Board of Directors for KPH Healthcare in Syracuse, a national pharmaceutical and healthcare services provider with complementary businesses in retail and commercial segments of these industries. The company is comprised of Kinney Drugs, with 100 full-service drug stores in New York and Vermont; Health Direct Institutional Pharmacy Services for long-term care and alternative care needs; ProAct, Inc., a national pharmacy-benefit management company and mail order pharmacy; and Noble Health Services, a specialty pharmacy dispensing complex and chronic disease medications. KPH has annual revenue over \$1 billion and 3,000 employees.

Joe was on the Board of Directors of the National Association of Chain Drug Stores (NACDS), representing traditional drug stores, supermarkets, and mass merchants totaling 40,000 pharmacies, 3.2 million employees including 178,000 pharmacies; the Board of Directors for Chain Drug Consortium (CDC), consisting of eight large regional retail pharmacy chains in the U.S. and Puerto Rico; and the Board of Directors of Data-Rx, providing pharmacy benefit

EXHIBIT 3.10 STAFFING STRUCTURE

management solutions, health saving programs, and pharmacy technology services for insurance brokers, third party administrators, employers, municipalities, HMOs, hospitals, and pharmacy groups in the United States.

Third Party Legal Advisor - The Legal Advisor will give accurate and timely counsel to the executive leadership team on Division regulations, labor law, and risk factors regarding business decisions and operations. The Legal Advisor will also review and evaluate compliance issues and concerns to ensure NSM is compliant with the rules set forth by the Department and all applicable state and local laws, regulations, ordinances, and other requirements.

Harry E. ("Bud") Cummins III, Third Party Compliance Officer - Bud Cummins is an attorney licensed in good standing in Arkansas since 1989. He graduated from the University of Arkansas in 1981 with a degree in finance and real estate, and earned his JD from the University of Arkansas at Little Rock (Bowen School of Law) in 1989. His law practice is Law Offices of Bud Cummins, PLC; Cummins served as a federal law clerk to a U.S. Magistrate Judge and to the Chief U.S. District Judge for the Eastern District of Arkansas. He was Chief Legal Counsel to Governor Mike Huckabee, and presidentially-appointed U.S. Attorney for the Eastern District of Arkansas from 2001 to 2006. Bud's private law practice specializes in compliance, internal investigations, litigation, and federal criminal defense.

Vice President IT & Business Development - Implements and oversees information and communications technology strategies of NSM. Responsibilities include ensuring a secure communications infrastructure that is HIPAA-compliant, reliable, strategically sound, and cost-efficient. This position will oversee programming voice and data telecommunications network circuits and equipment and computer systems networks, communication methods and devices, inventory tracking systems, alarm systems and surveillance systems. He/she will be responsible for ensuring the accuracy of all NSM inventory. Additional responsibilities include developing strategic communication plans; building and sustaining NSM's reputation for quality, reliability, and customer satisfaction; and overseeing the creation, maintenance, and continuous improvement of NSM's website, social media platforms, and business development processes.

Robert DeBin, Owner, VP IT and Business Development - Robert was born in Arkansas and attended the University of Arkansas. He has a graduate certificate in Enterprise Systems with a concentration in SAP Enterprise Resource Planning. Following college, Robert gained six years of experience configuring and implementing point of sale and inventory tracking systems for restaurants and retail stores. In February 2013, Robert formed RockIT City Solutions, DBA CLU Solutions. In April 2015, Robert partnered with a group out of Louisiana and began offering iPad based retail. In January of 2016, CLU began offering IT consulting services to the cannabis industry in Colorado. CLU has worked with medical marijuana point of sale providers and advised dispensary operators and cannabis cultivators to help streamline IT practices.

While working in Colorado, Robert completed METRC training (the first all regulatory, seed-to-sale solution for cannabis). METRC was deployed in December 2013 for the State of Colorado's Marijuana Enforcement Division, and supports marijuana regulations with technology to prevent and monitor drug diversions. The system has 20,000 users and has tracked

EXHIBIT 3.10 STAFFING STRUCTURE

over 5,000,000 plants and 3,800,000 packages. Robert's deep understanding of point of sale and inventory tracking combined with experience and training in seed-to-sale tracking software will be a valuable resource for NSM, and help establish best practices for compliance.

Vice President Community Outreach - This position will work with the Medical Advisory and Business Advisory Boards to plan and market community outreach events, such as the substance abuse prevention program, community education sessions, physician education program, and the compassionate care program. He/she will conduct outreach to identify local community organizations with which to partner, working closely with NSM's Controller to ensure availability of necessary funding for NSM's outreach programs, develop required planning and reporting documents to qualify efforts, and spearhead programs. The CP of Community Outreach will continually engage local businesses owners and community organizations, as well as individuals, leaders, and organizers in the area to identify the community's needs and ensure our organization has a positive impact on the community. The VP will be responsible for government relations activities including monitoring local, state and federal legislation and regulations and reporting possible impact to the executive leadership team, and maintaining communication with state legislative and administrative officials (advising them as appropriate) of cannabis industry concerns.

Donna Terrell, Owner, VP Community Outreach - A personal tragedy is what drives Fox16's television news anchor Donna Terrell to seek involvement as NSM's Community Outreach Coordinator. Donna's daughter, Queah, lost her battle with colon cancer at age 29. Donna knows medical marijuana may not have saved her life, but would have greatly improved its quality. Queah's death inspired Donna to help other young people dealing with cancer. Queah was introduced to yoga through a program at her Texas hospital, and said it made her feel more at ease from side effects of traditional cancer drugs. Queah's experience is the inspiration for 'Donna Terrell's Yoga Warriors Fighting Colon Cancer', a 501(c)3 nonprofit organization. Yoga Warriors was designed to raise awareness and help all cancer survivors. Through donations, Yoga Warriors successfully raises money to provide liquid nutritional supplements to cancer survivors needing financial assistance. It is also the brainchild and financier for free yoga classes for cancer survivors, patients, and caregivers on the campus at the CARTI Cancer Center facility.

In addition to being an award-winning news anchor and reporter, the 30-year television veteran also created a business model and launched her own company called Q-Impact, LLC. Through Q-Impact, she utilizes her skills in television news, marketing, and different social media platforms. She is often asked to give motivational speeches and emcee at various community events throughout the state. Donna has also performed duties for AETN, Arkansas' Public Television Station. Community service and volunteering are a passion for Donna. She has served on several executive boards for nonprofit groups including Women and Children First Domestic Violence, Arkansas' Susan G. Komen Breast Cancer Foundation, and Ronald McDonald House. She has been an Ambassador for the American Cancer Society, traveling to Washington, D.C., to speak to congressional members and help shape cancer policies.

Director of Security - The Director of Security will oversee the installation and operation of security systems; ensure compliance with rules set forth by the Department and Division and all

EXHIBIT 3.10 STAFFING STRUCTURE

applicable state and local laws, regulations, ordinances, and other requirements; and ensure safety measures for all cannabis products in transport are developed and followed. The Director of Security will work closely with managers to ensure employees are trained on and follow all NSM security SOPs. The Director of Security will oversee security officers, staff, and outside contractors to ensure compliance with NSM's security policies and procedures and all applicable laws and Department and Division regulations.

Lance Huey, Director of Security - Lance enlisted in the United States Marine Corps in 1983 and served for 7 years. He attained the rank of Sergeant (E-5) and was honorably discharged in 1990. Lance has an extensive career in Arkansas law enforcement and highly-regulated business. Lance spent over 20 years as an Arkansas State Trooper prior to being elected as Sheriff of Grant County for two terms. At that time, the Arkansas Lottery Commission was newly formed and had a task very similar to that of the Arkansas Medical Marijuana Commission. Lance was the inaugural Director of Security for the Arkansas Scholarship Lottery. He was tasked with hiring and screening of staff as well as secure transportation of tickets and all security and integrity of the program. Lance's long-time experience will be invaluable in establishing good working relationships with law enforcement officials throughout the state.

Human Resources Manager - The Human Resources Manager will be responsible for providing consultation to management and implementing strategic staffing plans, compensation, benefits, training and development, budget, and labor relations at the direction of the NSM executive leadership team. The Human Resources Manager will ensure employees are compliant with all personnel policies and training requirements.

Human Resource Manager - The hiring criteria for the Human Resource Manager includes a minimum of five (5) years experience in Human Resources positions, with two (2) of the five (5) years in a management level Human Resource position. He/She must have completed specialized training in employment law, compensation, organizational planning, organization development, employee relations, safety, training, and preventive labor relations (preferred). An active affiliation with appropriate Human Resources networks and organizations and ongoing community involvement and a Bachelor's degree or higher is a required.

Cultivation Manager - The Cultivation Manager (CM) will report directly to the General Manager. He/She will be responsible for supervising all phases of NSM's cultivation operations including: regulatory compliance, all cultivation phases, harvesting and curing of cannabis, quality assurance, and inventory control. The CM will work closely with the Laboratory Director and Laboratory Employees in strain identification and assessment of cannabis plants using DNA isolation methods and DNA processing. The CM will be responsible for micropropagation and tissue culture techniques, including genetic manipulation and genetic fidelity. The CM will ensure all employees follow Good Agricultural Practices and Good Handling Practices, and that crop records are maintained and retained properly. The CM will be responsible for keeping and protecting all inventory and ensuring accuracy of inventory in cultivation areas. This includes utilizing inventory tracking tools and overseeing compliance. The CM will ensure incoming materials for use in cultivation areas are receipted and managed appropriately, and when all

EXHIBIT 3.10 STAFFING STRUCTURE

complete, cannabis is transferred to the processing areas following inventory transfer and chain of custody protocols

Andrew Salini, Cultivation Manager - Andrew is a Princeton graduate who oversees business operations of three cannabis cultivation facilities and four dispensaries in Colorado for High Country Healing, an industry leader in Colorado and the U S Andrew has a strong background in business development and finance as a portfolio manager for EMF, a fixed income hedge fund with a \$500 million AUM from 2011-2014. He has worked as an investment banker for Deutsche Bank and Credit Suisse. Andrew will be relocating to Arkansas to supervise all aspects of production of our product

Laboratory Manager - The Laboratory Director (LM) will directly report to the General Manager. He/She will be responsible for overall operation and administration of the laboratory, planning and directing quality assurance policies, and development, maintenance, and sanitation SOPs. The LM will direct and ensure appropriate testing systems in the laboratory; provide quality services in all aspects of test performance; ensure physical and environmental conditions of the laboratory are adequate and appropriate; ensure employee environment is safe from physical, chemical, and biological hazards; ensure safety and biohazard requirements are followed; and ensure Good Laboratory Practices are followed. The LM is responsible for keeping and protecting all lab inventory and ensuring its accuracy through consistent use of the inventory tracking system.

Josh Risley, Laboratory Manager - In June of 2015, Josh partnered to open Cannabis Maximus, a profitable, well-regarded, and licensed cannabis concentrate manufacturing company. The lab Josh and his team designed and built meets FDA clinical standards as well as achieving the pinnacle of OSHA safety compliance (Class I Division I); this ensures it will withstand the ever-tightening regulations around light hydrocarbon cannabis extractions. Because no other cannabis extraction labs in the world had been built to this standard, Cannabis Maximus pioneered the process for true Class I Division I cannabis extraction processing. Cannabis Maximus' manufacturing and sales operations began with practically no budget as a new and unknown brand. Within 8 months of opening operations, Cannabis Maximus consistently grosses between \$100,000 - \$120,000 of revenue every month, has grown from 5 to 20 employees, is sold in over 40 CO retail dispensary locations, and is recognized as one of the premier concentrate brands in Colorado

Sales Manager - This sales manager will directly report to the General Manager, and create and execute a sustainable, measurable medical cannabis sales and marketing strategy. He/She will work directly with the executive team to build critical relationships across the local cannabis concentrates industry, and execute strategies that achieve short- and long-term revenue goals. He/She will build and manage the call center for incoming sales inquiries and oversee inside sales. He/She will coordinate with the the VP of IT and Business Development regarding full implementation and functionality of the inventory tracking system to capture necessary information from sales. He/She will oversee the integration of the Inventory Tracking Tool with our ERP system to properly track product movement and inventory levels based upon sales

EXHIBIT 3.10 STAFFING STRUCTURE

information. He/She will develop, train, and manage an Inside Sales team and establish commissions and territories/regions based growth of the business.

Marketing Strategy Manager - Ideal qualifications for this position include a minimum of five (5) years of business development, marketing, and sales experience, three (3) years of which are in the local cannabis concentrates industry. He/She must have excellent organization, communication, and presentation skills, and a demonstrated ability to effectively understand business strategy and vision. He/She must have familiarity with sales data analysis and reporting. This individual must have a Bachelor's degree in business or marketing, or a related field; a Master's degree is preferred.

Sales Representative - The two (2) Sales Representative positions will be directly overseen by the Sales Manager. As a team, they will aim to execute NSM's sales and marketing strategy. They will help build critical relationships across the local cannabis industry and execute strategies that achieve short- and long-term revenue goals. They will maintain a territory and assist with call center operations for incoming sales inquiries and fully utilize the Inventory Tracking and ERP Tools to capture necessary information from sales. Ideal qualifications for these positions include a minimum of three (3) years of business development, marketing, and sales experience; excellent organization, communication and presentation skills; a demonstrated ability to effectively understand business strategy and vision; familiarity with sales data analysis and reporting; and a Bachelor's degree in business, marketing, or a related field.

Supervisors - Supervisory positions are integral to NSM's operations. On the cultivation side, there will be three (3) Supervisors directly reporting to the Cultivation Manager. On the Extraction side, there will be one (1) Process Supervisor directly reporting to the Laboratory Manager. Cultivation Supervisors are responsible for supervising all phases of NSM's cultivation operations including: regulatory compliance, all phases of cultivation and production of cannabis products, quality assurance, inventory control, purchasing, and receiving of raw materials and supplies. On the extraction side, the Process Supervisor will work closely with the Laboratory Manager to implement, maintain, verify, validate, and continuously improve the overall Quality Systems and Food Safety (Safe Quality Food - SQF) programs for the facility, including HACCP¹, and Good Manufacturing Practices. Supervisors will directly oversee cultivation lead and support staff in their respective areas to ensure all employees are adequately trained in safe and sanitary methods of cultivating, processing, packaging, and labeling procedures in the production of NSM's cannabis products. They will be experts in operating the Inventory Tracking Tool and ERP, and train and oversee all subordinates to ensure quality controls.

Cultivation Employees - Cultivation Employees (CEs) include the roles of six (6) Leads and nine (9) Support Staff. These positions will be responsible for day-to-day cultivation tasks under the direct supervision of their Supervisor and will also be overseen by the Cultivation Manager. Cultivation employees will be involved in the all phases of NSM's cultivation operations

¹ Hazard Analysis and Critical Control Points - "A systematic preventive approach to food safety from biological, chemical, and physical hazards in production processes." This certificate focuses on what can cause products to be unsafe, and teaches methods to reduce these risks to a safe level.

EXHIBIT 3.10 STAFFING STRUCTURE

including room care, pest and environmental monitoring, pruning, watering, room turnover, sanitization, inventory tracking, manicuring, harvest, and curing. Cultivation Employees must have the ability to follow company SOPs related to growing, harvesting, inventory tracking, sanitation, and cross-contamination. They must operate, analyze, and troubleshoot complex digital machinery by following manufacturer's instructions. These positions require solid knowledge of medical cannabis cultivation and a demonstrated ability to keep records, take detailed notes, and report abnormalities to a Supervisor. A high school degree is required to hold positions as a Lead or Support; a college degree is preferred. Individuals holding a Lead position will demonstrate superior skills related to cultivating with an ability to oversee Support Staff with compliance to all SOPs.

Extraction Employees - Hiring qualifications of NSM's Extraction Employees (EEs) require at least five (5) years experience overseeing processing operations, preferably related to extraction of cannabis products for a Process Supervisor. EEs must have working knowledge of cannabis as a plant, including its chemical makeup, capability of being grown, refined/extracted, and the best methods for achieving a consistent product. These individuals must demonstrate the ability to enforce compliance with state and federal regulations with respect to the state board of health, the Alcoholic Beverage Control Division and regulations for WPS and OSHA. EEs must have at least two years of extraction experience with specific experience in tracking and recording tasks, utilizing an Inventory Tracking System, and a Bachelor's degree in agriculture, biology, botany, chemistry, or a related field of study.

Process Employees - Process Employees (PEs) will consist of two (2) Process Leads and two (2) Support positions. PEs will be directly supervised by the Process Supervisor and overseen by the Laboratory Manager. They will be responsible for testing and analysis for potency and safety and working with Cultivation Employees (CEs) to identify genetic markers. Laboratory Employees (LEs) will conduct internal cannabis testing during the curing phase, holding stage, and after packaging and labeling as directed by the Laboratory Manager. They will maintain strict adherence to all applicable SOPs and maintain consistency with all inventory tracking processes. All PEs must have two (2) years experience in a horticultural or agricultural environment with intermediate math skills, calculations understanding, and demonstrated ability to keep proper records and report abnormalities to the lab manager. A high school degree is required to hold this position; a college degree is preferred. The two (2) Process Leads will possess superior skills, experience, and/or education and demonstrated ability to oversee Support Staff with compliance to all laboratory responsibilities.

Security Officers - Security Officers (SOs) will be responsible for implementing and suggesting improvements to NSM security procedures, authorizing entrance and departure from NSM's facility, and other duties assigned by the Director of Security. SOs must have at least three (3) years experience in law enforcement, security or loss prevention. Experience in de-escalation and non-violent problem resolution will be highly desired. They must be comfortable sitting or standing for long periods of time; a high school diploma is required for this role.

EXHIBIT 3.11 NSM TIMELINE

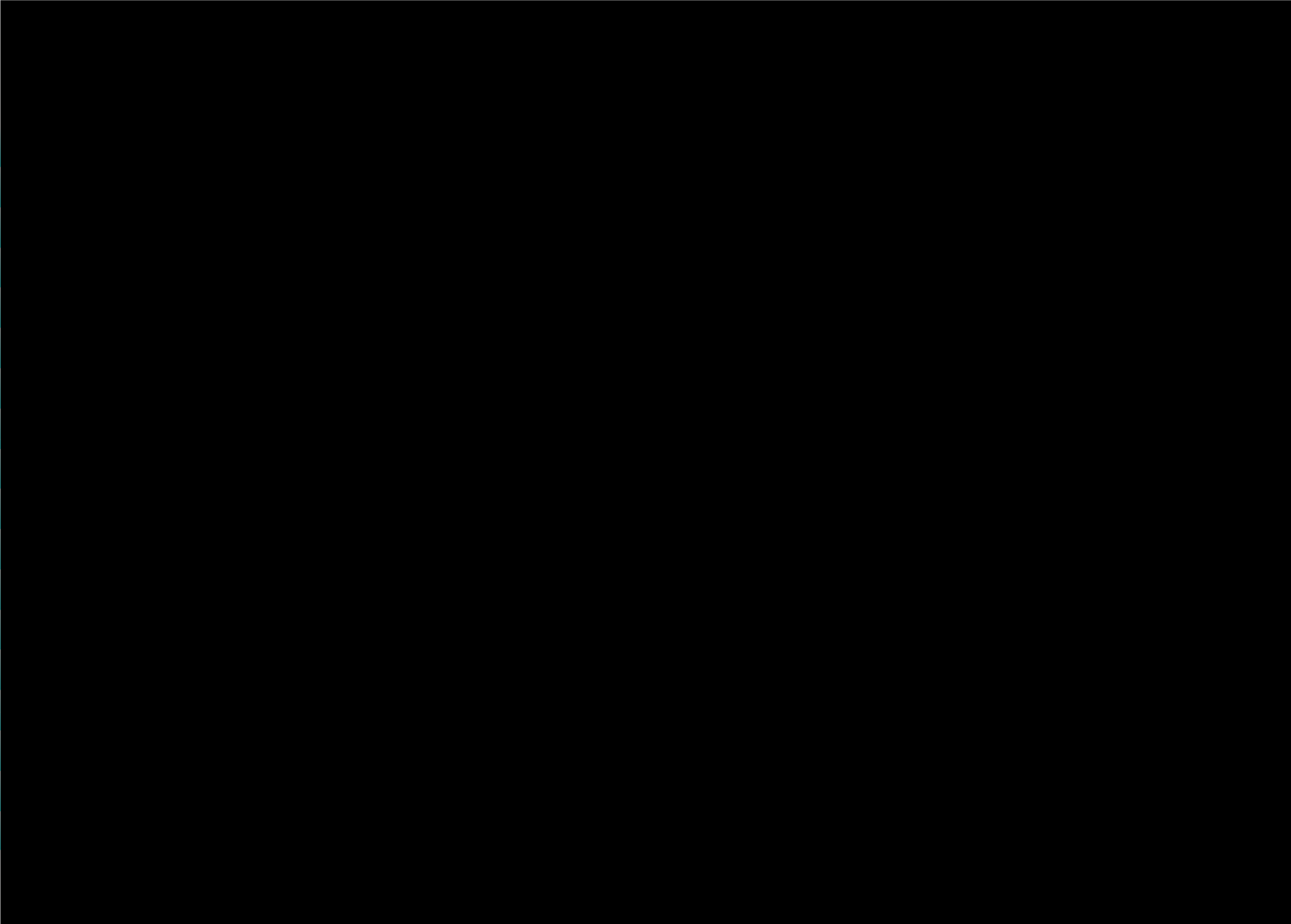

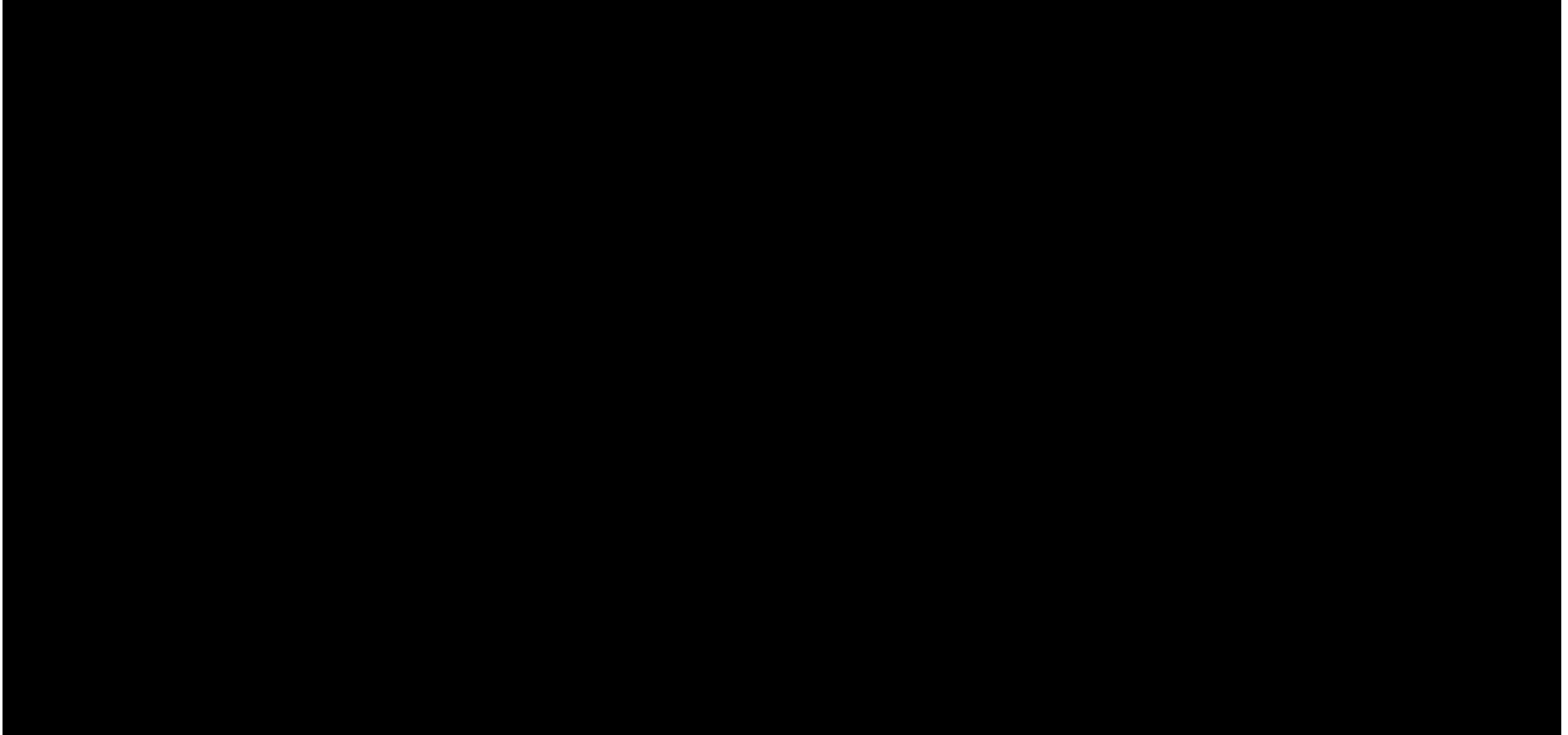

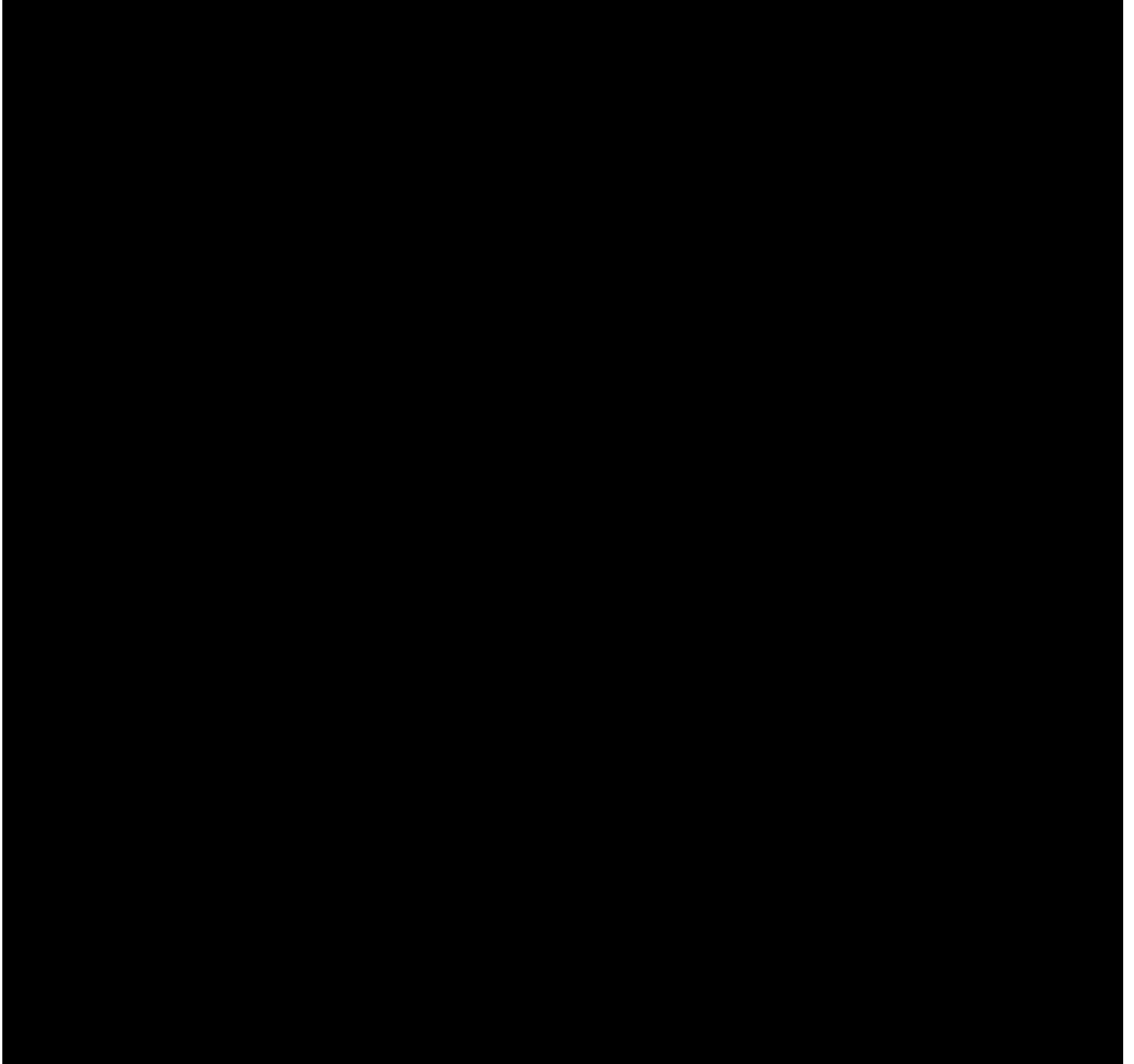

The material on this page is requested to be CONFIDENTIAL and redacted from any
Freedom of Information Request



The material on this page is requested to be CONFIDENTIAL and redacted from any Freedom of Information Request

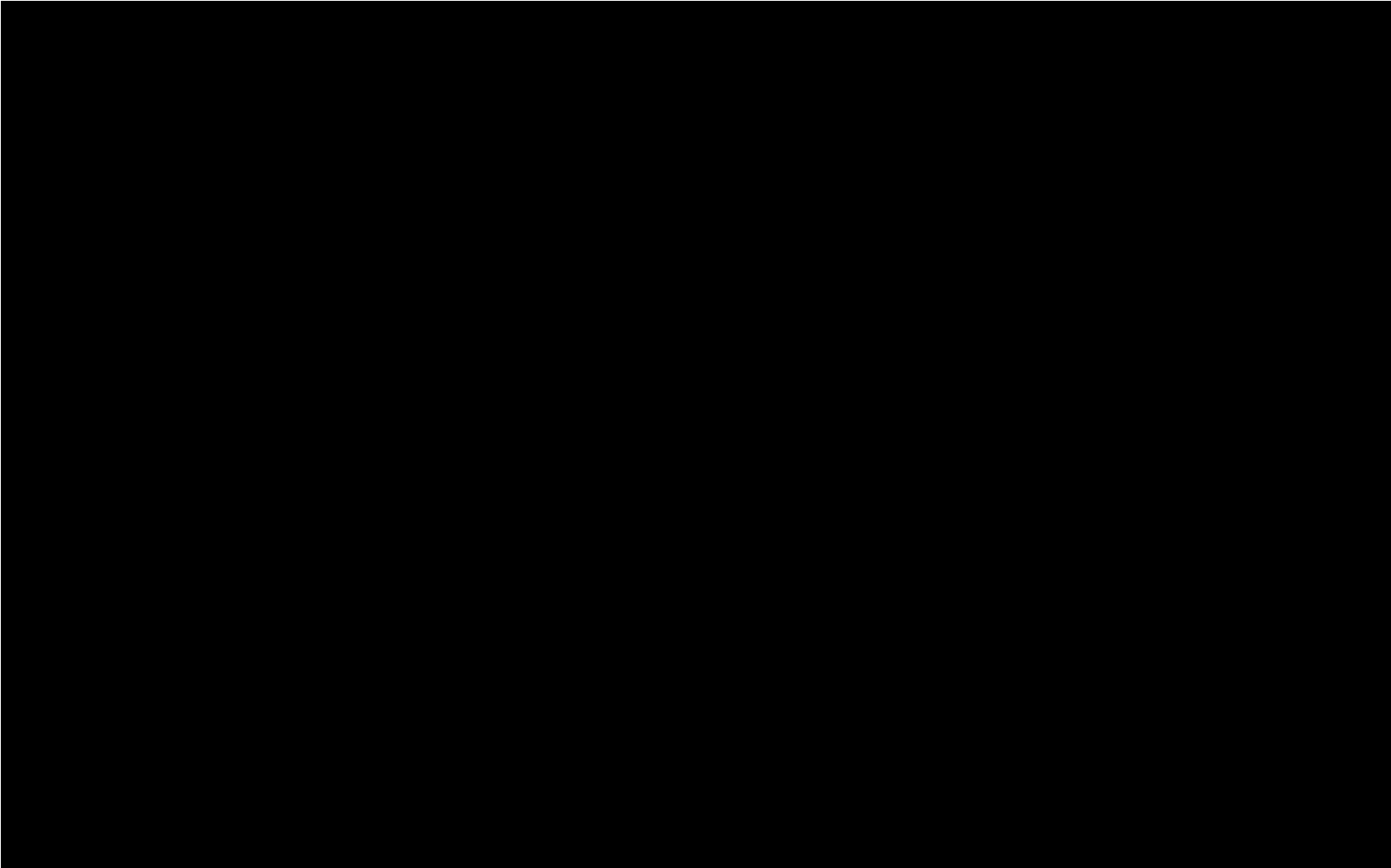

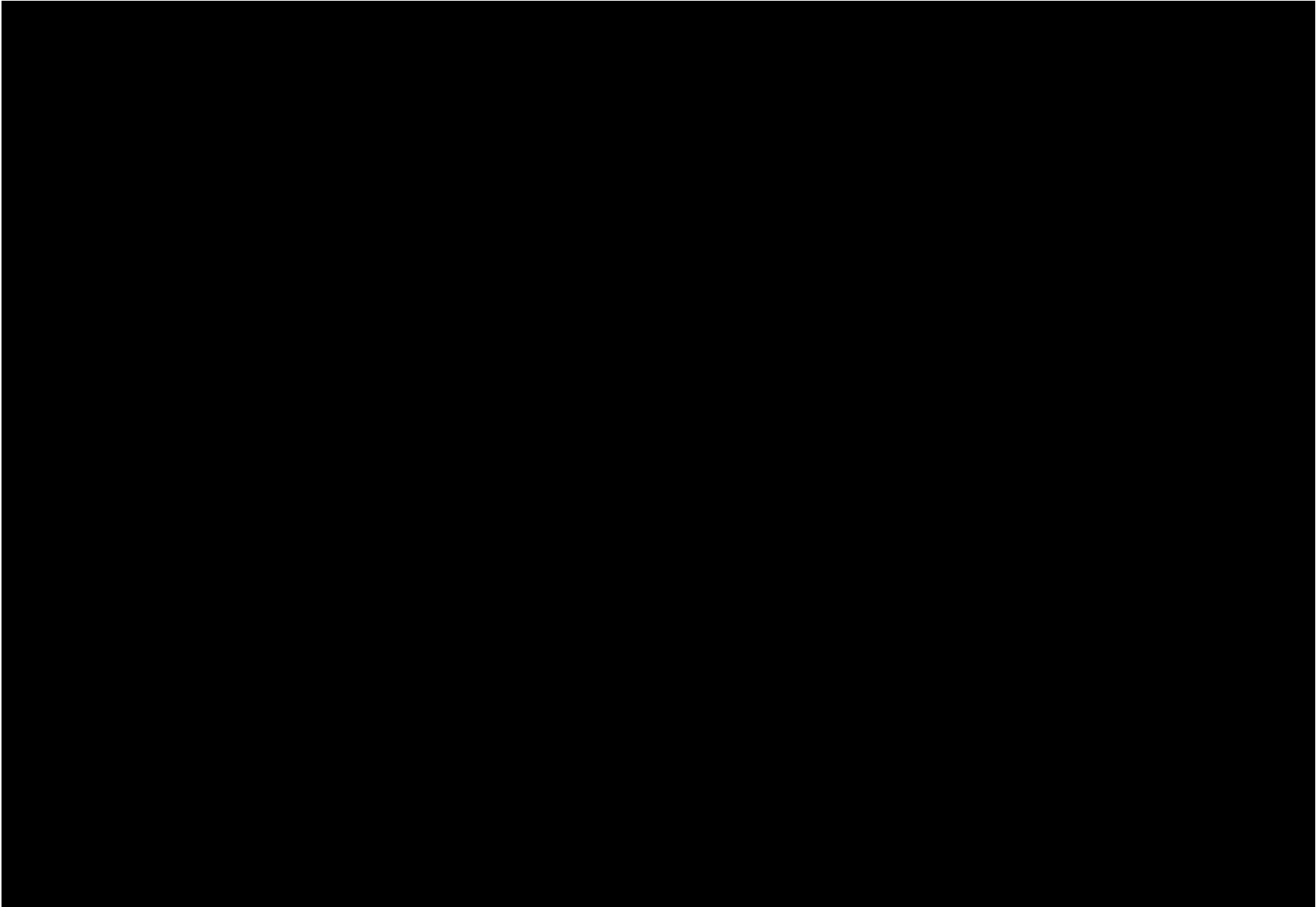

The material on this page is requested to be CONFIDENTIAL and redacted from any Freedom of Information Request

Natural State Medicinals Cultivation

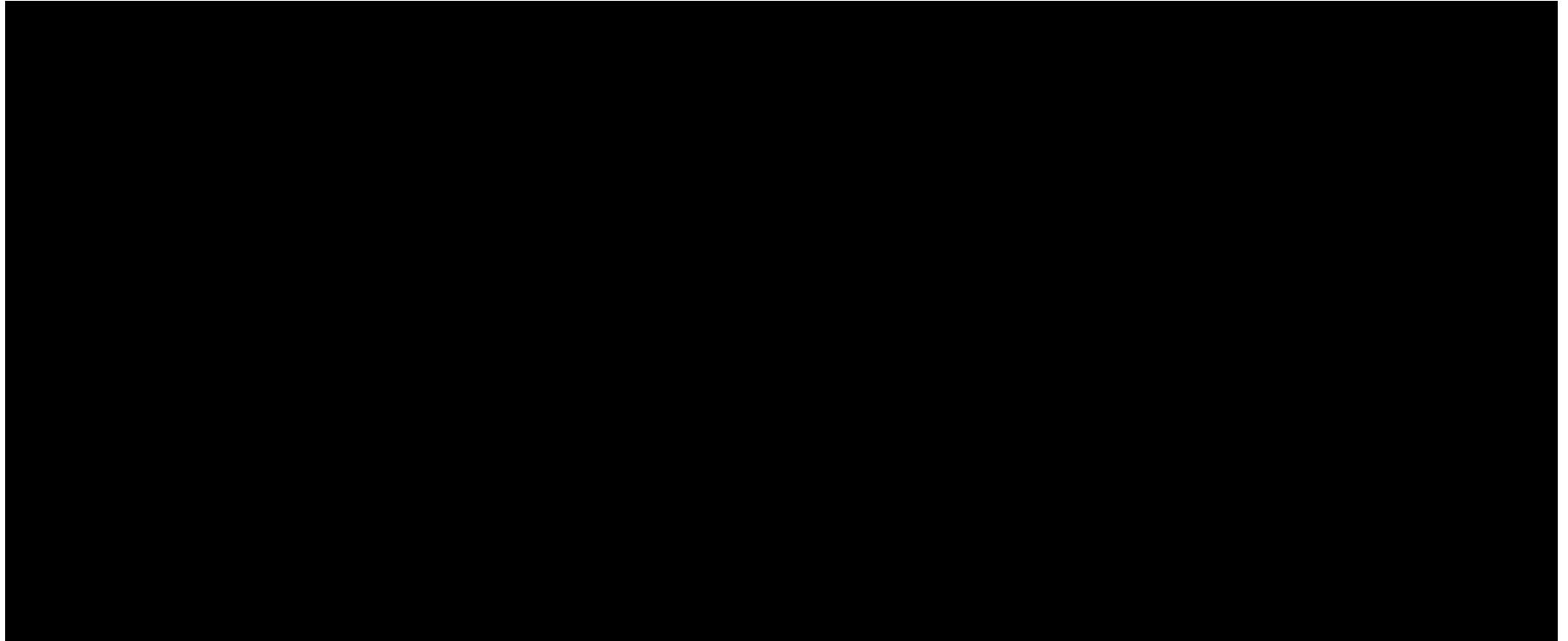

The material on this page is requested to be CONFIDENTIAL and redacted from any Freedom of Information Request

Natural State Medicinals Cultivation

ELLISVILLE DRUGS
INCOME STATEMENT
SEPTEMBER 30, 2012

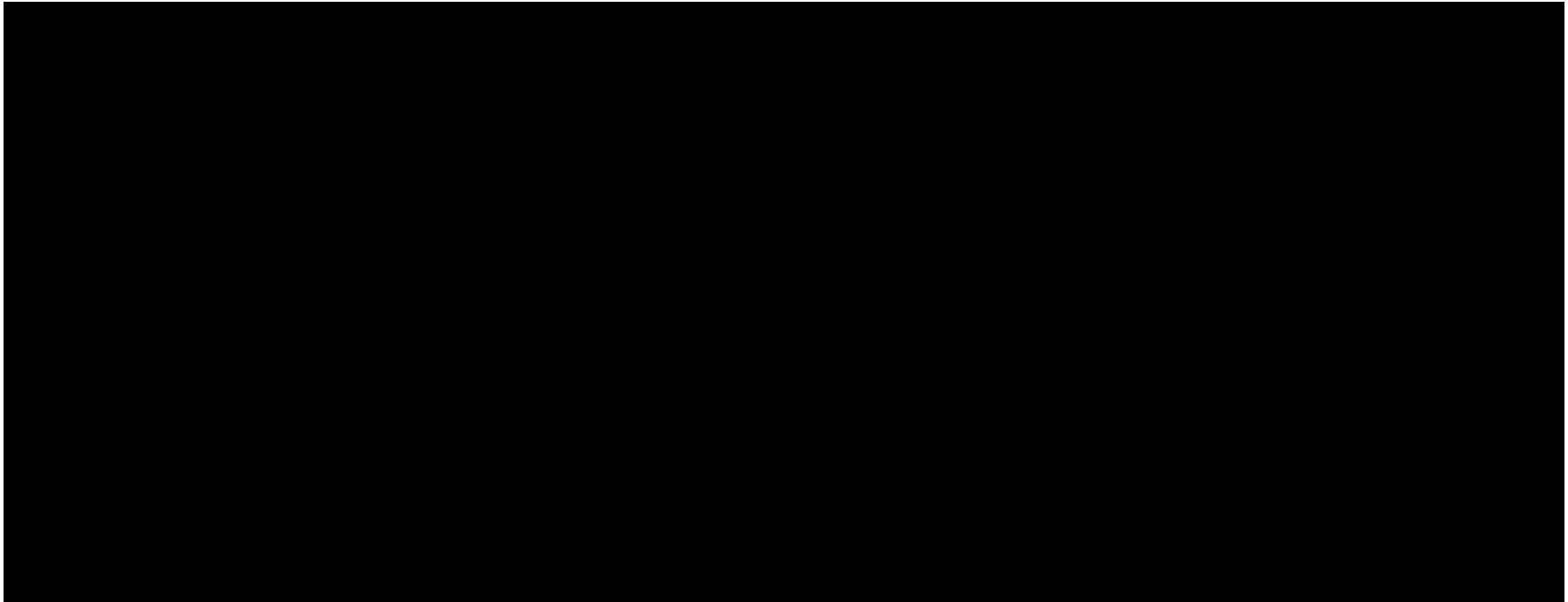

The material on this page is requested to be CONFIDENTIAL and redacted from any Freedom of Information Request

Natural State Medicinals Cultivation

JARCO PHARMACIES
CONSOLIDATED COMPANY
RESULT OF OPERATION
SEPTEMBER 30, 2012

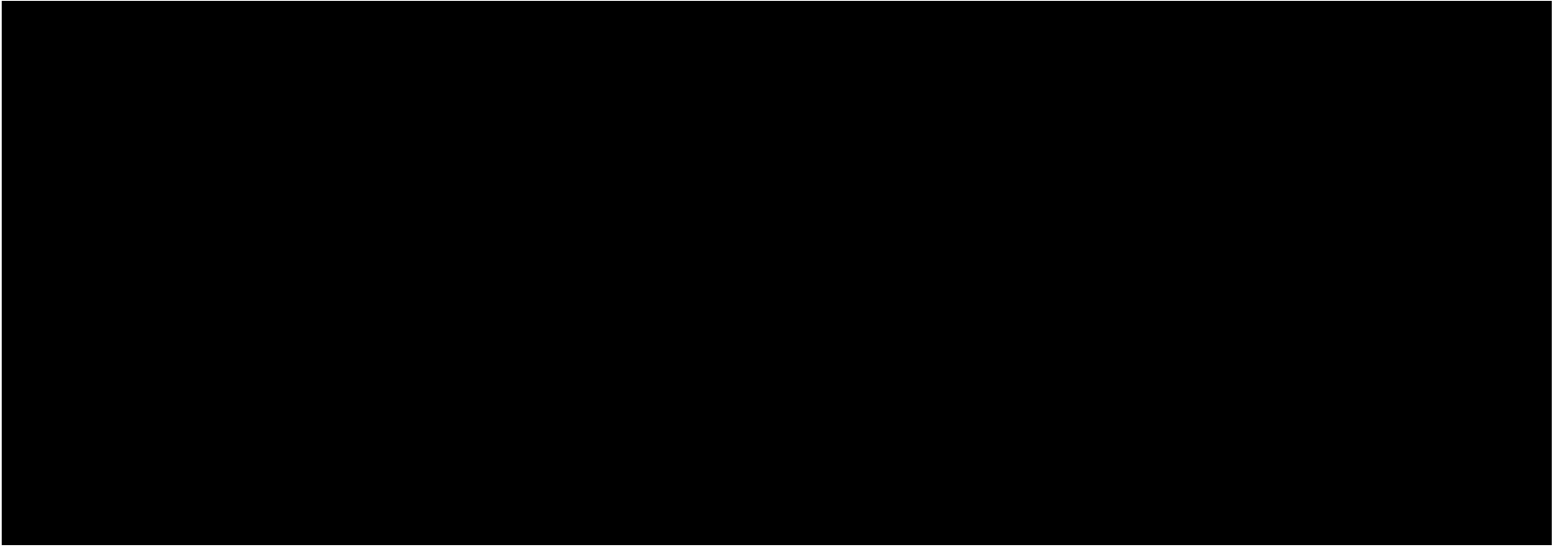

The material on this page is requested to be CONFIDENTIAL and redacted from any Freedom of Information Request



The material on this page is requested to be CONFIDENTIAL and redacted from any Freedom of Information Request

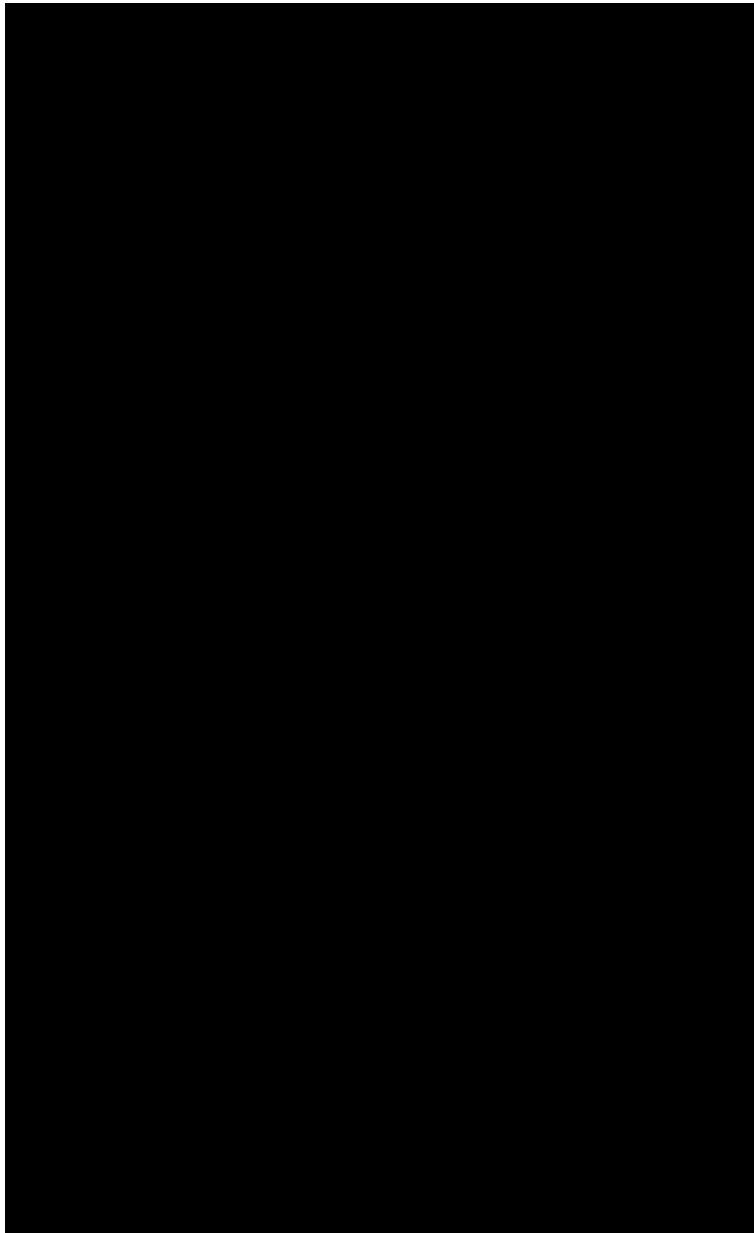

The material on this page is requested to be CONFIDENTIAL and redacted from any Freedom of Information Request

Natural State Medicinals Cultivation

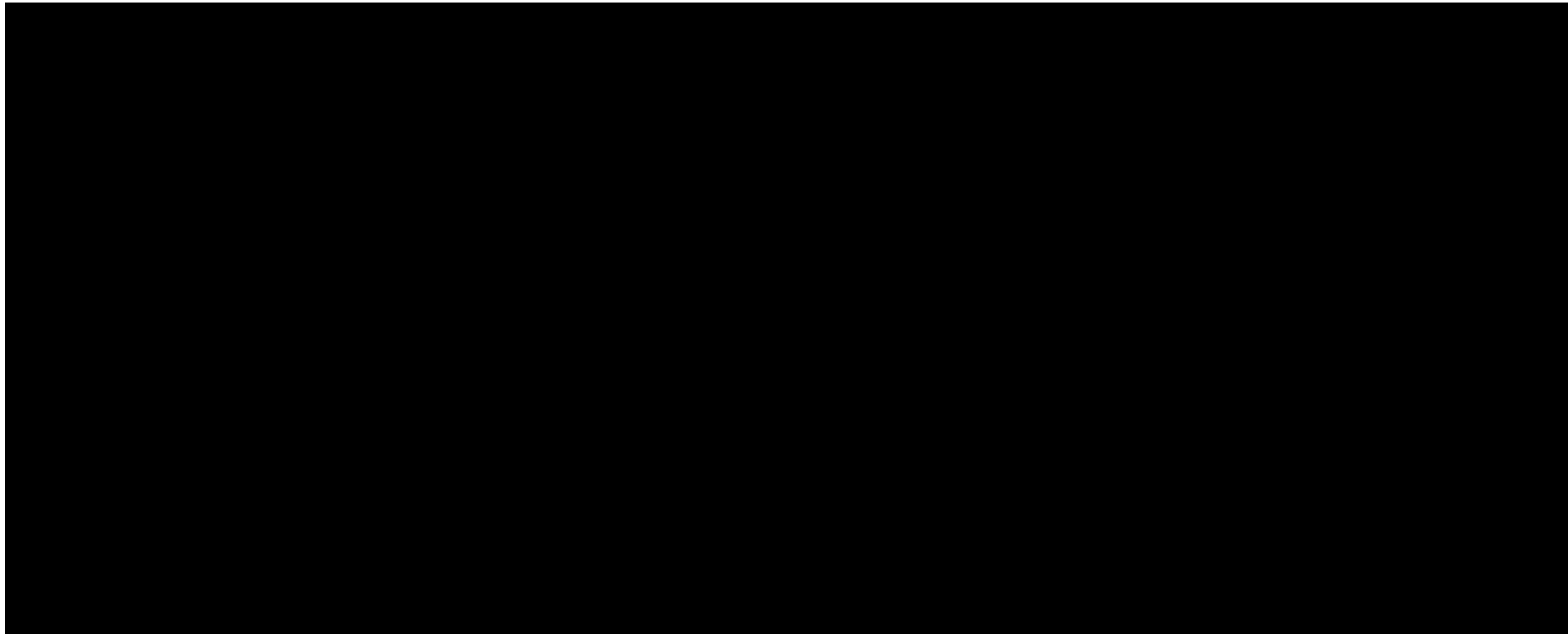

The material on this page is requested to be CONFIDENTIAL and redacted from any Freedom of Information Request

Natural State Medicinals Cultivation

JARCO PHARMACIES
CONSOLIDATED COMPANY
RESULT OF OPERATION
SEPTEMBER 30, 2012

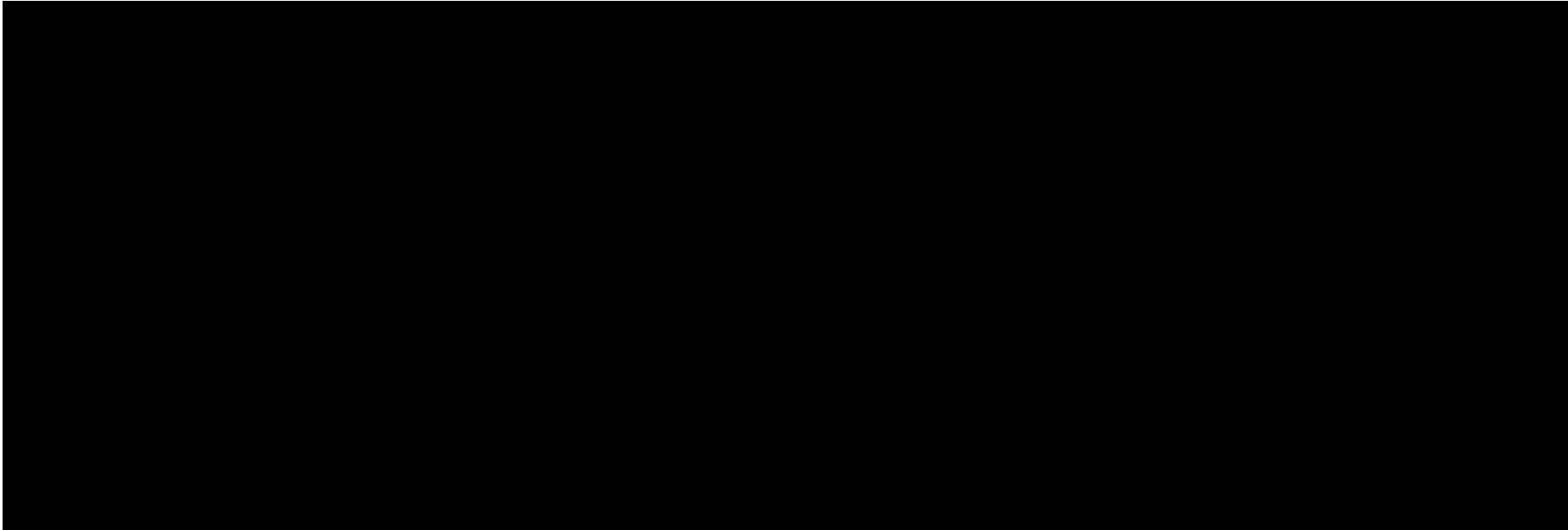

The material on this page is requested to be CONFIDENTIAL and redacted from any Freedom of Information Request

Natural State Medicinals Cultivation



The material on this page is requested to be CONFIDENTIAL and redacted from any Freedom of Information Request



[Redacted]

[Redacted]

[Redacted]

[Redacted]

[Redacted]

[Redacted]

[Redacted]

[Redacted]

[Redacted]

[Redacted]

Hopkins & Howard, P.C.
[Redacted]

AFFIDAVIT

STATE OF ARKANSAS
COUNTY OF PULASKI

KNOW ALL PERSONS BY THESE PRESENTS:

Before the undersigned notary public, duly qualified and acting in and for said county and state, personally appeared Alonzo Williams to me well known or satisfactorily proven to be the affiant herein, who, after being duly sworn, stated the following under oath:

1. My name is Alonzo Williams and I currently reside at [REDACTED]

2. I have never filed bankruptcy under any federal or state law, and no proceedings in bankruptcy have ever been instituted by or against me in any U.S. Bankruptcy court or any bankruptcy court of any state or other jurisdiction.

3. I have neither owned nor operated an entity that has filed bankruptcy under any federal or state law, and no proceedings in bankruptcy have ever been instituted by or against any entity owned or operated by me in any U.S Bankruptcy court or any bankruptcy court of any state or other jurisdiction.

4. I was not a party named in Bankruptcy Petition # 6:13-bk-74164 filed in the U.S. Bankruptcy Court, Western District of Arkansas.

I have read the foregoing statements and they are true and correct to the best of my knowledge and belief.

[Remainder of page intentionally left blank; signature page follows.]

EXHIBIT 4.4 BANKRUPTCY SEARCH

IN WITNESS WHEREOF, I hereunto set my hand this ___ day of August, 2017.

AFFELANT:

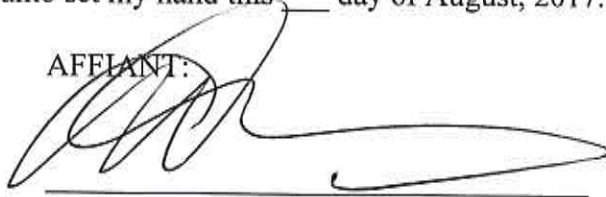

Alonzo Williams

Subscribed and sworn to before me this 33 day of August, 2017.

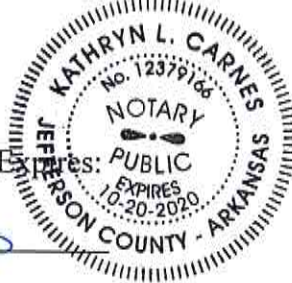

My Commission Expires:

10/20/20

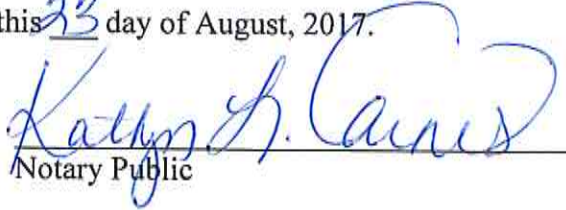

Notary Public



a Wolters Kluwer Business

EXHIBIT 44 BANKRUPTCY SEARCH

Search Results

LEAH ROVNAGHI
Friday Eldredge & Clark
400 West Capitol Avenue
Suite 2000
Little Rock, AR 72201

Date: 07/21/2017
Order #: 59842764
Customer #: 504120
Reference 1: USBC / AR
Reference 2: --

Target Name: Williams, Alonzo

Jurisdiction: U.S. Bankruptcy Court, Arkansas Eastern District

Search Type: Bankruptcy - Searched as Petitioner
Results: No Records Found

Searched Through: 07/14/2017
Searched: 10 Years
Office: Eastern District

BRIAN H. LEFEVRE
Chicago Team 1
208 S. LaSalle Street
Suite 814
Chicago, IL 60604
(888) 829-5817 Ext.3582
Brian.LeFevre@wolterskluwer.com

This report contains information compiled from sources which CT Lien Solutions considers reliable but does not control. The information provided is not a certified record of the applicable jurisdiction unless otherwise indicated. CT Lien Solutions does not (i) warrant or guarantee the accuracy, completion or timeliness of the information provided or (ii) accept any liability for delays, errors or omissions in the information provided. CT Lien Solutions is not an insurer with regard to this information or these services. Under no circumstances shall CT Lien Solutions be liable for any loss of underlying collateral or loss (or decreased priority) of security interest in connection with this information or these services. Any categorization of search results is provided for convenience only and is not to be construed as a legal opinion concerning the status of filings.

Search Results

LEAH ROVNAGHI
Friday Eldredge & Clark
400 West Capitol Avenue
Suite 2000
Little Rock, AR 72201

Date: 07/21/2017
Order #: 59842764
Customer #: 504120
Reference 1: USBC / AR
Reference 2: --

Target Name: Williams, Alonzo

Jurisdiction: U.S. Bankruptcy Court, Arkansas Western District

Search Type: Bankruptcy - Searched as Petitioner

Results: See Attached Listing of Records Found with 8 Copies
Attached

Searched Through: 07/14/2017

Searched: 10 Years

Office: Western District

Document Listing:

File #	File Date	Chapter Type
13-bk-74164	12/26/2013	Chapter 13

BRIAN H. LEFEVRE
Chicago Team 1
208 S. LaSalle Street
Suite 814
Chicago, IL 60604
(888) 829-5817 Ext.3582
Brian.LeFevre@wolterskluwer.com

This report contains information compiled from sources which CT Lien Solutions considers reliable but does not control. The information provided is not a certified record of the applicable jurisdiction unless otherwise indicated. CT Lien Solutions does not (i) warrant or guarantee the accuracy, completion or timeliness of the information provided or (ii) accept any liability for delays, errors or omissions in the information provided. CT Lien Solutions is not an insurer with regard to this information or these services. Under no circumstances shall CT Lien Solutions be liable for any loss of underlying collateral or loss (or decreased priority) of security interest in connection with this information or these services. Any categorization of search results is provided for convenience only and is not to be construed as a legal opinion concerning the status of filings.

**U.S. Bankruptcy Court
Western District of Arkansas (Hot Springs)
Bankruptcy Petition #: 6:13-bk-74164**

Assigned to: Judge Ben T Barry
Chapter 13
Voluntary
Asset

Date filed: 12/26/2013
Date terminated: 08/27/2014
Debtor dismissed: 05/15/2014

Debtor disposition: Dismissed for Other Reason

Debtor

Shaniece Lachelle Williams
PO Box 3191
Hot Springs National, AR 71914
GARLAND-AR
SSN / ITIN: xxx-xx-2912
aka Shaniece Davison
aka Shaniece Lealie

represented by **James C. Hunt**

Jack W. Gooding, Standing
Ch 13 Trustee
P.O. Box 8202
Little Rock, AR 72221
501-537-4400, (5)
Email: jhunt@ark13.com

Trustee

Jack W. Gooding
Chapter 13 Standing Trustee
P.O. Box 8202
Little Rock, AR 72221-8202
(501)537-4400, (5)

U.S. Trustee

U.S. Trustee (ust)
Office Of U. S. Trustee
200 W Capitol, Ste. 1200
Little Rock, AR 72201
501.324.7357, (5)

Filing Date	#	Docket Text
12/26/2013	<u>1</u> (49 pgs)	Chapter 13 Voluntary Petition. Fee Amount \$0. Filed by Shaniece Lachelle Williams. (Hunt, James) (Entered: 12/26/2013)
12/26/2013	<u>2</u> (1 pg)	Certificate of Credit Counseling Filed by James C. Hunt on behalf of Debtor Shaniece Lachelle Williams (Hunt, James) (Entered: 12/26/2013)

Exhibit 4 4

EXHIBIT 4 4 BANKRUPTCY SEARCH

12/26/2013	<u>3</u> (5 pgs)	Chapter 13 Plan Filed by James C. Hunt on behalf of Debtor Shaniece Lachelle Williams. Court ONLY Deadline 11/30/2018. (Hunt, James) (Entered: 12/26/2013)
12/26/2013	<u>4</u> (1 pg)	Application for Compensation Filed by James C. Hunt on behalf of Shaniece Lachelle Williams (Hunt, James) (Entered: 12/26/2013)
12/26/2013	<u>5</u> (1 pg)	Application or Motion to Pay Filing Fee in Installments. Filed by James C. Hunt on behalf of Shaniece Lachelle Williams (Hunt, James) (Entered: 12/26/2013)
12/27/2013		Clerk's Evidence of Repeat Filings for debtor Shaniece Lachelle Williams Case Number <u>12-73829</u> , Chapter 13 filed in Arkansas Western Bankruptcy Court on 10/11/2012.(Admin) (Entered: 12/27/2013)
12/27/2013	<u>6</u> (2 pgs; 2 docs)	Order Granting Application or Motion To Pay Filing Fee In Installments. Payment in full due by the first date set for the meeting of creditors (Related Doc # <u>5</u>). Entered on Docket 12/27/2013 (Bell, Allison) (Entered: 12/27/2013)
12/27/2013	<u>7</u> (3 pgs; 2 docs)	Meeting of Creditors 341(a) meeting to be held on 2/27/2014 at 08:30 AM at Hot Springs First Meeting Room. Last day to oppose dischargeability is 4/28/2014. Proofs of Claims due by 5/28/2014. (Warren, Gale) (Entered: 12/27/2013)
12/29/2013	<u>8</u> (4 pgs)	BNC Certificate of Mailing - Meeting of Creditors (RE: related document(s) <u>7</u> Meeting of Creditors 341 (a) meeting to be held on 2/27/2014 at 08:30 AM at Hot Springs First Meeting Room. Last day to oppose dischargeability is 4/28/2014. Proofs of Claims due by 5/28/2014.) No. of Notices: 18. Notice Date 12/29/2013. (Admin.) (Entered: 12/29/2013)
12/29/2013	<u>9</u> (2 pgs)	BNC Certificate of Mailing(RE: related document(s) <u>6</u> Order Granting Application or Motion To Pay Filing Fee In Installments. Payment in full due by the first date set for the meeting of creditors (Related Doc <u>5</u>). Entered on Docket 12/27/2013 (Bell, Allison)) No. of Notices: 1. Notice Date 12/29/2013. (Admin.) (Entered: 12/29/2013)

Exhibit 4 4 12/31/2013	EXHIBIT 4 4 BANKRUPTCY SEARCH <u>10</u> (1 pg)	Order to Pay Trustee (wtrustee) (Entered: 12/31/2013)
01/29/2014	<u>11</u> (1 pg)	Notice of Appearance and Request for Notice filed by Heather A. Buchberger Creditor Credit Acceptance Corporation. (Buchberger, Heather) (Entered: 01/29/2014)
01/30/2014	<u>12</u> (5 pgs)	Objection to Confirmation of Plan Filed by Heather A. Buchberger on behalf of Creditor Credit Acceptance Corporation (Buchberger, Heather) (Entered: 01/30/2014)
01/31/2014	<u>13</u> (2 pgs; 2 docs)	Hearing scheduled(RE: related document(s) <u>12</u> Objection to Confirmation of Plan Filed by Heather A. Buchberger on behalf of Creditor Credit Acceptance Corporation filed by Creditor Credit Acceptance Corporation) Hearing scheduled for 2/20/2014 at 09:00 AM at Hot Springs Division. (Scales, Erika) (Entered: 01/31/2014)
02/02/2014	<u>14</u> (2 pgs)	BNC Certificate of Mailing - Hearing(RE: related document(s) <u>13</u> Hearing scheduled(RE: related document(s) <u>12</u> Objection to Confirmation of Plan Filed by Heather A. Buchberger on behalf of Creditor Credit Acceptance Corporation filed by Creditor Credit Acceptance Corporation) Hearing scheduled for 2/20/2014 at 09:00 AM at Hot Springs Division.) No. of Notices: 1. Notice Date 02/02/2014. (Admin.) (Entered: 02/02/2014)
02/14/2014	<u>15</u> (7 pgs; 2 docs)	Chapter 13 AMENDED Plan With Notice of Opportunity to Object/Respond, Notice of Opportunity to Object/Respond to Plan AND Certificate of Service. Filed by James C. Hunt on behalf of Debtor Shaniece Lachelle Williams (RE: related document(s) <u>3</u> Chapter 13 Plan filed by Debtor Shaniece Lachelle Williams) (Attachments: # <u>1</u> matrix)(Hunt, James) (Entered: 02/14/2014)
02/14/2014	<u>16</u> (3 pgs)	Additional Application for Compensation Filed by James C. Hunt on behalf of Shaniece Lachelle Williams (Hunt, James) (Entered: 02/14/2014)
02/14/2014	<u>17</u> (1 pg)	Notice of Opportunity to Object/Respond to (related documents <u>16</u> Application for Compensation 13). Certificate of Service.(RE: related document(s) <u>16</u> Application for Compensation 13 filed by Debtor

Exhibit 4 4

EXHIBIT 4 4 BANKRUPTCY SEARCH

		Shaniece Lachelle Williams) (Hunt, James) (Entered: 02/14/2014)
02/18/2014	<u>18</u> (1 pg)	Order Revoking the Order to Pay Trustee (wtrustee) (Entered: 02/18/2014)
02/18/2014	<u>19</u> (1 pg)	Order to Pay Trustee (wtrustee) (Entered: 02/18/2014)
02/19/2014	20	Hearing Scheduled For 2/20/2014 Not Held. Settled Prior to the Hearing (Sustained with 21 Days to Modify; Buchberger)(RE: related document(s) <u>12</u> Objection to Confirmation of Plan Filed by Heather A. Buchberger on behalf of Creditor Credit Acceptance Corporation filed by Creditor Credit Acceptance Corporation) (Thalheimer, Mary-Tipton) (Entered: 02/19/2014)
02/19/2014	<u>21</u> (3 pgs; 2 docs)	Agreed Order Granting Relief from Stay Entered on 2/19/2014 (Williams, Lisa) (Entered: 02/19/2014)
02/19/2014	<u>22</u> (3 pgs; 2 docs)	Order Sustaining Credit Acceptance Corp.'s Objection to Confirmation of Plan(RE: related document(s) <u>12</u> Objection to Confirmation of Plan Filed by Heather A. Buchberger on behalf of Creditor Credit Acceptance Corporation filed by Creditor Credit Acceptance Corporation) Entered on 2/19/2014 (Bell, Allison) (Entered: 02/19/2014)
02/20/2014	<u>23</u> (1 pg)	Motion for Relief from Stay Re: Co-Debtor Alonzo Williams . Filed by Heather A. Buchberger on behalf of Credit Acceptance Corporation (Buchberger, Heather) (Entered: 02/20/2014)
02/21/2014	<u>24</u> (2 pgs; 2 docs)	Hearing scheduled(RE: related document(s) <u>23</u> Motion for Relief from Stay Re: Co-Debtor Alonzo Williams . Filed by Heather A. Buchberger on behalf of Credit Acceptance Corporation filed by Creditor Credit Acceptance Corporation) Hearing scheduled for 3/27/2014 at 09:00 AM at Hot Springs Division. (Scales, Erika) (Entered: 02/21/2014)
02/23/2014	<u>25</u> (1 pg)	Objection to Confirmation of Amended Plan Filed by Trustee (wtrustee) (Entered: 02/23/2014)
02/23/2014	<u>26</u> (2 pgs)	BNC Certificate of Mailing - Hearing(RE: related document(s) <u>24</u> Hearing scheduled(RE: related document(s) <u>23</u> Motion for Relief from Stay Re: Co-

Exhibit 4 4

EXHIBIT 4 4 BANKRUPTCY SEARCH

		Debtor Alonzo Williams . Filed by Heather A. Buchberger on behalf of Credit Acceptance Corporation filed by Creditor Credit Acceptance Corporation) Hearing scheduled for 3/27/2014 at 09:00 AM at Hot Springs Division.) No. of Notices: 1. Notice Date 02/23/2014. (Admin.) (Entered: 02/23/2014)
02/24/2014	<u>27</u> (2 pgs; 2 docs)	Hearing scheduled(RE: related document(s) <u>25</u> Objection to Confirmation of Amended Plan Filed by Trustee (wtrustee)) Hearing scheduled for 3/27/2014 at 09:00 AM at Hot Springs Division. (Scales, Erika) (Entered: 02/24/2014)
02/26/2014	<u>28</u> (2 pgs)	BNC Certificate of Mailing - Hearing(RE: related document(s) <u>27</u> Hearing scheduled(RE: related document(s) <u>25</u> Objection to Confirmation of Amended Plan Filed by Trustee (wtrustee)) Hearing scheduled for 3/27/2014 at 09:00 AM at Hot Springs Division.) No. of Notices: 1. Notice Date 02/26/2014. (Admin.) (Entered: 02/27/2014)
02/27/2014	29	Acknowledgment that a Chapter 13 Filing Fee Is Due and Payable On-Line in FULL Filed by James C. Hunt on behalf of Shaniece Lachelle Williams (Hunt, James) (Entered: 02/27/2014)
02/27/2014	30	RECEIPT of Chapter 13 Final Payment in FULL (6:13-bk-74164) [misc,ak13] (281.00) Filing Fee. receipt number 5327961, amount \$ 281.00. (U.S. Treasury) (Entered: 02/27/2014)
02/27/2014	<u>31</u> (7 pgs; 3 docs)	Motion to Waive / Excuse Appearance at 341 Meeting Filed by James C. Hunt on behalf of Shaniece Lachelle Williams (Attachments: # <u>1</u> Exhibit A # <u>2</u> matrix) (Hunt, James) (Entered: 02/27/2014)
03/11/2014	<u>32</u> (2 pgs; 2 docs)	Meeting of Creditors Continued for Debtor(s) 341(a) meeting to be held on 4/17/2014 at 08:30 AM at Hot Springs First Meeting Room. (Warren, Gale) (Entered: 03/11/2014)
03/11/2014	<u>33</u> (1 pg)	Order on Application For Compensation Ch. 13 (wtrustee) (Entered: 03/11/2014)
03/13/2014	<u>34</u> (3 pgs)	BNC Certificate of Mailing(RE: related document(s) <u>32</u> Meeting of Creditors Continued for Debtor(s) 341 (a) meeting to be held on 4/17/2014 at 08:30 AM at

Exhibit 4 4

EXHIBIT 4 4 BANKRUPTCY SEARCH

		Hot Springs First Meeting Room.) No. of Notices: 30. Notice Date 03/13/2014. (Admin.) (Entered: 03/14/2014)
03/14/2014	<u>35</u> (2 pgs)	BNC Certificate of Mailing(RE: related document(s) <u>33</u> Order on Application For Compensation Ch. 13 (wtrustee)) No. of Notices: 1. Notice Date 03/14/2014. (Admin.) (Entered: 03/14/2014)
03/17/2014	<u>36</u> (2 pgs; 2 docs)	Order On Motion For Relief From Stay As To Co-Debtor(Related Doc # <u>23</u>) Entered on Docket 3/17/2014 (Williams, Lisa) (Entered: 03/17/2014)
03/17/2014	<u>37</u> (3 pgs; 2 docs)	Order Granting Motion To Waive / Excuse Appearance at 341 Meeting (Related Doc # <u>31</u>) Entered on Docket 3/17/2014 (Williams, Lisa) (Entered: 03/17/2014)
03/19/2014	<u>38</u> (2 pgs)	BNC Certificate of Mailing(RE: related document(s) <u>36</u> Order On Motion For Relief From Stay As To Co-Debtor(Related Doc <u>23</u>) Entered on Docket 3/17/2014 (Williams, Lisa)) No. of Notices: 1. Notice Date 03/19/2014. (Admin.) (Entered: 03/19/2014)
03/19/2014	<u>39</u> (4 pgs)	BNC Certificate of Mailing(RE: related document(s) <u>37</u> Order Granting Motion To Waive / Excuse Appearance at 341 Meeting (Related Doc <u>31</u>) Entered on Docket 3/17/2014 (Williams, Lisa)) No. of Notices: 30. Notice Date 03/19/2014. (Admin.) (Entered: 03/19/2014)
03/26/2014	40	Hearing Not Held. Settled or Continued Prior to the Hearing (RE: Objection to Confirmation of Amended Plan - related document(s) <u>25</u>) (Sustained with 30 days to Document (Trustee))(Albritton, Allison) (Entered: 03/26/2014)
04/01/2014	<u>41</u> (1 pg)	Order to Provide Further Documentation to the Trustee (wtrustee) (Entered: 04/01/2014)
04/03/2014	<u>42</u> (1 pg)	Motion to Dismiss Case for Failure to Make Plan Payments Filed by Trustee (wtrustee) (Entered: 04/03/2014)
04/07/2014	<u>43</u> (3 pgs)	Additional Application for Compensation Filed by James C. Hunt on behalf of Shaniece Lachelle Williams (Hunt, James) (Entered: 04/07/2014)

Exhibit 4 4

~~EXHIBIT 4 4 BANKRUPTCY SEARCH~~

04/07/2014	<u>44</u> (1 pg)	Notice of Opportunity to Object/Respond to (related documents <u>43</u> Application for Compensation 13). Certificate of Service.(RE: related document(s) <u>43</u> Application for Compensation 13 filed by Debtor Shaniece Lachelle Williams) (Hunt, James) (Entered: 04/07/2014)
04/14/2014	<u>45</u> (2 pgs; 2 docs)	Notice of Requirement to Complete Course in Financial Management (admin) (Entered: 04/14/2014)
04/17/2014	<u>46</u> (2 pgs)	BNC Certificate of Mailing(RE: related document(s) <u>45</u> Notice of Requirement to Complete Course in Financial Management (admin)) No. of Notices: 1. Notice Date 04/17/2014. (Admin.) (Entered: 04/17/2014)
05/01/2014	<u>47</u> (2 pgs; 2 docs)	Meeting of Creditors - Second Non-Appearance Scheduled 4/17/2014 for Debtor(s) with Notice of Opportunity to Respond. Filed by Trustee (Warren, Gale) (Entered: 05/01/2014)
05/03/2014	<u>48</u> (3 pgs)	BNC Certificate of Mailing(RE: related document(s) <u>47</u> Meeting of Creditors - Second Non-Appearance Scheduled 4/17/2014 for Debtor(s) with Notice of Opportunity to Respond. Filed by Trustee) No. of Notices: 31. Notice Date 05/03/2014. (Admin.) (Entered: 05/03/2014)
05/07/2014	<u>49</u> (1 pg)	Motion to Dismiss Case filed by Trustee (wtrustee) (Entered: 05/07/2014)
05/08/2014	<u>50</u> (2 pgs; 2 docs)	Hearing scheduled(RE: related document(s) <u>49</u> Motion to Dismiss Case filed by Trustee (wtrustee)) Hearing scheduled for 6/18/2014 at 09:00 AM at Hot Springs Division. (Scales, Erika) (Entered: 05/08/2014)
05/10/2014	<u>51</u> (2 pgs)	BNC Certificate of Mailing - Hearing(RE: related document(s) <u>50</u> Hearing scheduled(RE: related document(s) <u>49</u> Motion to Dismiss Case filed by Trustee (wtrustee)) Hearing scheduled for 6/18/2014 at 09:00 AM at Hot Springs Division.) No. of Notices: 1. Notice Date 05/10/2014. (Admin.) (Entered: 05/10/2014)
05/14/2014	<u>52</u> (1 pg)	Notice Regarding Hearing on Trustee's Motion to Dismiss (wtrustee) (Entered: 05/14/2014)

Exhibit 4.4 05/15/2014	EXHIBIT 4.4 BANKRUPTCY SEARCH <u>53</u> (5 pgs; 2 docs)	Motion to Dismiss Case <i>Motion to Voluntarily Dismiss Chapter 13</i> Filed by James C. Hunt on behalf of Shaniece Lachelle Williams (Attachments: # <u>1</u> matrix) (Hunt, James) (Entered: 05/15/2014)
05/15/2014	<u>54</u> (2 pgs; 2 docs)	Order Granting Motion to Dismiss Debtor (Related Doc # <u>53</u>) Entered on Docket 5/15/2014 (Williams, Lisa) (Entered: 05/15/2014)
05/17/2014	<u>55</u> (3 pgs)	BNC Certificate of Mailing(RE: related document(s) <u>54</u> Order Granting Motion to Dismiss Debtor (Related Doc <u>53</u>) Entered on Docket 5/15/2014 (Williams, Lisa)) No. of Notices: 31. Notice Date 05/17/2014. (Admin.) (Entered: 05/17/2014)
07/25/2014	<u>56</u> (4 pgs)	Chapter 13 Final Report and Account Filed by Trustee (wtrustee) (Entered: 07/25/2014)
08/23/2014	<u>57</u> (2 pgs; 2 docs)	Order that the Chapter 13 Trustee is Discharged and Relieved of his/her Trust in This Case (ADIClerk) (Entered: 08/23/2014)
08/27/2014	58	Bankruptcy Case Closed. The Trustee Has Performed All Duties Required and is Discharged From and Relieved of His Trust. (Wilkins, Tanya) (Entered: 08/27/2014)

PACER Service Center			
Transaction Receipt			
07/19/2017 15:03:22			
PACER Login:	mc0019:2593428:0	Client Code:	
Description:	Docket Report	Search Criteria:	6:13-bk-74164 Fil or Ent: filed From: 1/1/1980 To: 7/19/2017 Doc From: 0 Doc To: 99999999 Term: included Format: html Page counts for documents: included
Billable Pages:	5	Cost:	0.50



CT Lien Solutions

a Wolters Kluwer Business

EXHIBIT 4.4 BANKRUPTCY SEARCH

Search Results

LEAH ROVNAGHI
Friday Eldredge & Clark
400 West Capitol Avenue
Suite 2000
Little Rock, AR 72201

Date: 07/21/2017
Order #: 59842764
Customer #: 504120
Reference 1: USBC / AR
Reference 2: --

Target Name: Peck, Cliff

Jurisdiction: U.S. Bankruptcy Court, Arkansas Eastern District

Search Type: Bankruptcy - Searched as Petitioner
Results: No Records Found

Searched Through: 07/14/2017
Searched: 10 Years
Office: Eastern District

BRIAN H. LEFEVRE
Chicago Team 1
208 S. LaSalle Street
Suite 814
Chicago, IL 60604
(888) 829-5817 Ext.3582
Brian.LeFevre@wolterskluwer.com

This report contains information compiled from sources which CT Lien Solutions considers reliable but does not control. The information provided is not a certified record of the applicable jurisdiction unless otherwise indicated. CT Lien Solutions does not (i) warrant or guarantee the accuracy, completion or timeliness of the information provided or (ii) accept any liability for delays, errors or omissions in the information provided. CT Lien Solutions is not an insurer with regard to this information or these services. Under no circumstances shall CT Lien Solutions be liable for any loss of underlying collateral or loss (or decreased priority) of security interest in connection with this information or these services. Any categorization of search results is provided for convenience only and is not to be construed as a legal opinion concerning the status of filings.



Search Results

LEAH ROVNAGHI
Friday Eldredge & Clark
400 West Capitol Avenue
Suite 2000
Little Rock, AR 72201

Date: 07/21/2017
Order #: 59842764
Customer #: 504120
Reference 1: USBC / AR
Reference 2: --

Target Name: Peck, Cliff

Jurisdiction: U.S. Bankruptcy Court, Arkansas Western District

Search Type: Bankruptcy - Searched as Petitioner
Results: No Records Found

Searched Through: 07/14/2017
Searched: 10 Years
Office: Western District

BRIAN H. LEFEVRE
Chicago Team 1
208 S. LaSalle Street
Suite 814
Chicago, IL 60604
(888) 829-5817 Ext.3582
Brian.Lefevre@wolterskluwer.com

This report contains information compiled from sources which CT Lien Solutions considers reliable but does not control. The information provided is not a certified record of the applicable jurisdiction unless otherwise indicated. CT Lien Solutions does not (i) warrant or guarantee the accuracy, completion or timeliness of the information provided or (ii) accept any liability for delays, errors or omissions in the information provided. CT Lien Solutions is not an insurer with regard to this information or these services. Under no circumstances shall CT Lien Solutions be liable for any loss of underlying collateral or loss (or decreased priority) of security interest in connection with this information or these services. Any categorization of search results is provided for convenience only and is not to be construed as a legal opinion concerning the status of filings.

AFFIDAVIT

STATE OF ARKANSAS
COUNTY OF PULASKI

KNOW ALL PERSONS BY THESE PRESENTS:

Before the undersigned notary public, duly qualified and acting in and for said county and state, personally appeared Donna Mooney to me well known or satisfactorily proven to be the affiant herein, who, after being duly sworn, stated the following under oath:

1. My name is Donna Mooney and I currently reside at

2. I have never filed bankruptcy under any federal or state law, and no proceedings in bankruptcy have ever been instituted by or against me in any U.S. Bankruptcy court or any bankruptcy court of any state or other jurisdiction.

3. I have neither owned nor operated an entity that has filed bankruptcy under any federal or state law, and no proceedings in bankruptcy have ever been instituted by or against any entity owned or operated by me in any U.S. Bankruptcy court or any bankruptcy court of any state or other jurisdiction.

4. I am not the same Donna Mooney named as debtor in Bankruptcy Petition # 3:14-bk-11733 filed in the U.S. Bankruptcy Court, Eastern District of Arkansas.

5. The last four digits of my social security number are not 3046.

I have read the foregoing statements and they are true and correct to the best of my knowledge and belief.

[Remainder of page intentionally left blank; signature page follows.]

EXHIBIT 4 4 BANKRUPTCY SEARCH

IN WITNESS WHEREOF, I hereunto set my hand this 25th day of August, 2017.

AFFIANT:

Donna M. Mooney
Donna Mooney

Subscribed and sworn to before me this 25th day of August, 2017.

Jennifer Cate
Notary Public

My Commission Expires:

4/6/2019





Search Results

LEAH ROVNAGHI
Friday Eldredge & Clark
400 West Capitol Avenue
Suite 2000
Little Rock, AR 72201

Date: 07/21/2017
Order #: 59842764
Customer #: 504120
Reference 1: USBC / AR
Reference 2: --

Target Name: Peck, Deane

Jurisdiction: U.S. Bankruptcy Court, Arkansas Eastern District

Search Type: Bankruptcy - Searched as Petitioner
Results: No Records Found

Searched Through: 07/14/2017
Searched: 10 Years
Office: Eastern District

BRIAN H. LEFEVRE
Chicago Team 1
208 S. LaSalle Street
Suite 814
Chicago, IL 60604
(888) 829-5817 Ext.3582
Brian.Lefevre@wolterskluwer.com

This report contains information compiled from sources which CT Lien Solutions considers reliable but does not control. The information provided is not a certified record of the applicable jurisdiction unless otherwise indicated. CT Lien Solutions does not (i) warrant or guarantee the accuracy, completion or timeliness of the information provided or (ii) accept any liability for delays, errors or omissions in the information provided. CT Lien Solutions is not an insurer with regard to this information or these services. Under no circumstances shall CT Lien Solutions be liable for any loss of underlying collateral or loss (or decreased priority) of security interest in connection with this information or these services. Any categorization of search results is provided for convenience only and is not to be construed as a legal opinion concerning the status of filings.



Search Results

LEAH ROVNAGHI
Friday Eldredge & Clark
400 West Capitol Avenue
Suite 2000
Little Rock, AR 72201

Date: 07/21/2017
Order #: 59842764
Customer #: 504120
Reference 1: USBC / AR
Reference 2: --

Target Name: Peck, Deane

Jurisdiction: U.S. Bankruptcy Court, Arkansas Western District

Search Type: Bankruptcy - Searched as Petitioner
Results: No Records Found

Searched Through: 07/14/2017
Searched: 10 Years
Office: Western District

BRIAN H. LEFEVRE
Chicago Team 1
208 S. LaSalle Street
Suite 814
Chicago, IL 60604
(888) 829-5817 Ext.3582
Brian.LeFevre@wolterskluwer.com

This report contains information compiled from sources which CT Lien Solutions considers reliable but does not control. The information provided is not a certified record of the applicable jurisdiction unless otherwise indicated. CT Lien Solutions does not (i) warrant or guarantee the accuracy, completion or timeliness of the information provided or (ii) accept any liability for delays, errors or omissions in the information provided. CT Lien Solutions is not an insurer with regard to this information or these services. Under no circumstances shall CT Lien Solutions be liable for any loss of underlying collateral or loss (or decreased priority) of security interest in connection with this information or these services. Any categorization of search results is provided for convenience only and is not to be construed as a legal opinion concerning the status of filings.

Search Results

LEAH ROVNAGHI
Friday Eldredge & Clark
400 West Capitol Avenue
Suite 2000
Little Rock, AR 72201

Date: 07/21/2017
Order #: 59842764
Customer #: 504120
Reference 1: USBC / AR
Reference 2: --

Target Name: Mooney, Donna

Jurisdiction: U.S. Bankruptcy Court, Arkansas Eastern District

Search Type: Bankruptcy - Searched as Petitioner

Searched Through: 07/14/2017

Results: See Attached Listing of Records Found with 8 Copies
Attached

Searched: 10 Years

Office: Eastern District

Document Listing:

File #	File Date	Chapter Type
14-bk-11733	03/27/2014	Chapter 13

BRIAN H. LEFEVRE
Chicago Team 1
208 S. LaSalle Street
Suite 814
Chicago, IL 60604
(888) 829-5817 Ext.3582
Brian.LeFevre@wolterskluwer.com

This report contains information compiled from sources which CT Lien Solutions considers reliable but does not control. The information provided is not a certified record of the applicable jurisdiction unless otherwise indicated. CT Lien Solutions does not (i) warrant or guarantee the accuracy, completion or timeliness of the information provided or (ii) accept any liability for delays, errors or omissions in the information provided. CT Lien Solutions is not an insurer with regard to this information or these services. Under no circumstances shall CT Lien Solutions be liable for any loss of underlying collateral or loss (or decreased priority) of security interest in connection with this information or these services. Any categorization of search results is provided for convenience only and is not to be construed as a legal opinion concerning the status of filings.

Repeat

**U.S. Bankruptcy Court
Eastern District of Arkansas (Jonesboro)
Bankruptcy Petition #: 3:14-bk-11733**

Assigned to: Judge Phyllis M. Jones
Chapter 13
Voluntary
Asset

Date filed: 03/27/2014
Plan confirmed: 11/14/2014
Deadline for filing claims: 07/23/2014

Debtor

Randy Mooney
2075 Hwy 141 South
Paragould, AR 72450
GREENE-AR
SSN / ITIN: xxx-xx-9666

represented by **G. Mike DeLoache**
DeLOACHE LAW OFFICE
512 W. Washington Ave.
Jonesboro, AR 72401
(870) 932-4433
Fax : 870-277-4383
Email: mike@deloachelawoffice.com

Joint Debtor

Donna Mooney
2075 Hwy 141 South
Paragould, AR 72450
GREENE-AR
SSN / ITIN: xxx-xx-3046

represented by **G. Mike DeLoache**
(See above for address)

Trustee

Mark T. McCarty
Chapter 13 Standing Trustee
P.O. Box 5006
N. Little Rock, AR 72119-5006
501-374-1572

U.S. Trustee

U.S. Trustee (ust)
Office Of U. S. Trustee
200 W Capitol, Ste. 1200
Little Rock, AR 72201
501-324-7357

Filing Date	#	Docket Text
03/27/2014	<u>1</u> (60 pgs)	Chapter 13 Voluntary Petition. Fee Amount \$281 Filed by Randy Mooney, Donna Mooney. (DeLoache, G.) (Entered: 03/27/2014)

Exhibit 4.4

EXHIBIT 4.4 BANKRUPTCY SEARCH

03/27/2014	<u>2</u> (6 pgs)	Chapter 13 Plan Filed by G. Mike DeLoache on behalf of Joint Debtor Donna Mooney, Debtor Randy Mooney. Plan Completion Due Date Set 03/1/2019. (DeLoache, G.) (Entered: 03/27/2014)
03/27/2014	<u>3</u> (1 pg)	Application for Compensation Filed by G. Mike DeLoache on behalf of Donna Mooney, Randy Mooney (DeLoache, G.) (Entered: 03/27/2014)
03/27/2014	<u>4</u> (2 pgs)	Certificate of Credit Counseling Filed by G. Mike DeLoache on behalf of Joint Debtor Donna Mooney, Debtor Randy Mooney (DeLoache, G.) (Entered: 03/27/2014)
03/27/2014	5	RECEIPT of Voluntary Petition (Chapter 13)(3:14-bk-11733) [misc,volp13a] (281.00) Filing Fee. receipt number 9702404, amount \$ 281.00. (U.S. Treasury) (Entered: 03/27/2014)
03/28/2014		Clerk's Evidence of Repeat Filings for joint debtors Randy Mooney and Donna Mooney Case Number <u>02-20819</u> , Chapter 7 filed in Arkansas Eastern Bankruptcy Court on 09/23/2002 , Standard Discharge on 01/03/2003; Case Number <u>09-50042</u> , Chapter 7 filed in Florida Northern Bankruptcy Court on 01/29/2009 , Standard Discharge on 05/15/2009.(Admin) (Entered: 03/28/2014)
03/28/2014	<u>6</u> (3 pgs; 2 docs)	Meeting of Creditors 341(a) meeting to be held on 4/24/2014 at 01:30 PM at Jonesboro First Meeting Room. Last day to oppose dischargeability is 6/23/2014. Proofs of Claims due by 7/23/2014. (Poole, Melissa) (Entered: 03/28/2014)
03/28/2014	<u>7</u> (1 pg)	Order to Pay Trustee (emccarty) (Entered: 03/28/2014)
03/30/2014	<u>8</u> (4 pgs)	BNC Certificate of Mailing - Meeting of Creditors (RE: related document(s) <u>6</u> Meeting of Creditors 341 (a) meeting to be held on 4/24/2014 at 01:30 PM at Jonesboro First Meeting Room. Last day to oppose dischargeability is 6/23/2014. Proofs of Claims due by 7/23/2014.) No. of Notices: 11. Notice Date 03/30/2014. (Admin.) (Entered: 03/30/2014)
03/31/2014	<u>9</u> (1 pg)	Order on Application For Compensation Ch. 13 (emccarty) (Entered: 03/31/2014)

Exhibit 4 4
 04/01/2014

EXHIBIT 4 4 BANKRUPTCY SEARCH
 10

04/01/2014	10	Request by AmeriCredit Financial Services, Inc. dba GM Financial Designating Mailing Address for Notices pursuant to Bankruptcy Rule 2002(g)(1), requesting service of copies of all future notices at the address specified in the process of filing this Request. (Hogan, James) (Entered: 04/01/2014)
04/02/2014	<u>11</u> (2 pgs)	BNC Certificate of Mailing(RE: related document(s) <u>9</u> Order on Application For Compensation Ch. 13 (emccarty)) No. of Notices: 1. Notice Date 04/02/2014. (Admin.) (Entered: 04/03/2014)
04/07/2014	<u>12</u> (1 pg)	DUPLICATE ENTRY SEE #13 Notice of Appearance and Request for Notice filed by Matthew P. McKay Creditor Wells Fargo Bank, N.A.. (McKay, Matthew) Modified on 4/7/2014 (Atwood, Nicole). (Entered: 04/07/2014)
04/07/2014	<u>13</u> (1 pg)	Notice of Appearance and Request for Notice filed by Matthew P. McKay Creditor Wells Fargo Bank, N.A.. (McKay, Matthew) (Entered: 04/07/2014)
04/28/2014	14	Meeting of Creditors Held and Concluded on 4/24/14. Filed by Trustee (Jones, Michelle) (Entered: 04/28/2014)
05/06/2014	<u>15</u> (1 pg)	Objection to Confirmation of Plan Filed by Trustee (emccarty) (Entered: 05/06/2014)
05/07/2014	<u>16</u> (2 pgs; 2 docs)	Hearing SCHEDULED(RE: related document(s) <u>15</u> Objection to Confirmation of Plan Filed by Trustee (emccarty)) Hearing scheduled for 6/5/2014 at 10:00 AM at Jonesboro Division. (Robinson, Annette) (Entered: 05/07/2014)
05/09/2014	<u>17</u> (2 pgs)	BNC Certificate of Mailing - Hearing(RE: related document(s) <u>16</u> Hearing SCHEDULED(RE: related document(s) <u>15</u> Objection to Confirmation of Plan Filed by Trustee (emccarty)) Hearing scheduled for 6/5/2014 at 10:00 AM at Jonesboro Division.) No. of Notices: 2. Notice Date 05/09/2014. (Admin.) (Entered: 05/09/2014)
05/12/2014	<u>18</u> (1 pg)	Financial Management Course Certificate Filed filed by G. Mike DeLoache Debtor Randy Mooney. (DeLoache, G.) (Entered: 05/12/2014)
05/12/2014		

Exhibit 4 4

EXHIBIT 4 4 BANKRUPTCY SEARCH

	<u>19</u> (1 pg)	Financial Management Course Certificate Filed filed by G. Mike DeLoache Joint Debtor Donna Mooney. (DeLoache, G.) (Entered: 05/12/2014)
06/04/2014	20	Hearing Not Held. Settled or Continued Prior to the Hearing (RE: Objection to Confirmation of Plan - related document(s) <u>15</u>) (Hearing NOT Held 6/5/14; PER EMAIL FROM TRUSTEE - SUSTAINED W/ 21 TO MOD & DOC (A,B,C,D,I,22C,VOLUNTARY PETITION)) (Mansfield, MaryBeth) (Entered: 06/04/2014)
06/05/2014	<u>21</u> (1 pg)	Order to Modify Plan (emccarty) (Entered: 06/05/2014)
06/27/2014	<u>22</u> (14 pgs)	Amended Schedules/Statements Filed:Petition Page, Schedule A, Schedule B, Schedule C, Schedule D, Schedule I, [Fee Due No] Filed by G. Mike DeLoache on behalf of Joint Debtor Donna Mooney, Debtor Randy Mooney (DeLoache, G.) (Entered: 06/27/2014)
06/27/2014	<u>23</u> (7 pgs)	Chapter 13 Statement of Current Monthly and Disposable Income -(Form 22C) Filed by G. Mike DeLoache on behalf of Joint Debtor Donna Mooney, Debtor Randy Mooney (DeLoache, G.) (Entered: 06/27/2014)
06/27/2014	<u>24</u> (6 pgs; 2 docs)	Chapter 13 AMENDED Plan With Notice of Opportunity to Object/Respond, Notice of Opportunity to Object/Respond to Plan AND Certificate of Service. Filed by G. Mike DeLoache on behalf of Joint Debtor Donna Mooney, Debtor Randy Mooney (Attachments: # <u>1</u> Creditor Matrix) (DeLoache, G.) (Entered: 06/27/2014)
07/14/2014	<u>25</u> (1 pg)	Objection to Confirmation of Amended Plan Filed by Trustee (emccarty) (Entered: 07/14/2014)
07/15/2014	<u>26</u> (2 pgs; 2 docs)	Hearing SCHEDULED(RE: related document(s) <u>25</u> Objection to Confirmation of Amended Plan Filed by Trustee (emccarty)) Hearing scheduled for 9/11/2014 at 10:00 AM at Jonesboro Division. (Robinson, Annette) (Entered: 07/15/2014)
07/17/2014	<u>27</u> (2 pgs)	BNC Certificate of Mailing - Hearing(RE: related document(s) <u>26</u> Hearing SCHEDULED(RE: related document(s) <u>25</u> Objection to Confirmation of

Exhibit 4 4

EXHIBIT 4 4 BANKRUPTCY SEARCH

		Amended Plan Filed by Trustee (emccarty)) Hearing scheduled for 9/11/2014 at 10:00 AM at Jonesboro Division.) No. of Notices: 2. Notice Date 07/17/2014. (Admin.) (Entered: 07/18/2014)
09/10/2014	<u>28</u> (2 pgs; 2 docs)	Hearing Continued (RE:Objection to Confirmation of Amended Plan - related document(s) <u>25</u>) (Continued to 10/2/2014 10:00 AM at Jonesboro Division) (Hearing NOT Held 9/11/14; PER EMAIL FROM TRUSTEE - CONTINUED - PARTIES REQUESTED & AGREED)(Mansfield, MaryBeth) (Entered: 09/10/2014)
09/12/2014	<u>29</u> (2 pgs)	BNC Certificate of Mailing - Hearing(RE: related document(s) <u>28</u> Hearing Continued (RE:Objection to Confirmation of Amended Plan - related document (s) <u>25</u>) (Continued to 10/2/2014 10:00 AM at Jonesboro Division) (Hearing NOT Held 9/11/14; PER EMAIL FROM TRUSTEE - CONTINUED - PARTIES REQUESTED & AGREED)) No. of Notices: 2. Notice Date 09/12/2014. (Admin.) (Entered: 09/12/2014)
10/01/2014	30	Hearing Not Held. Settled or Continued Prior to the Hearing (RE: Objection to Confirmation of Amended Plan - related document(s) <u>25</u>) (HEARING NOT HELD 10/2/14, PER EMAIL FROM TRUSTEE, SUSTAINED W/ 21 TO MOD & DOC (I AND PAYSTUBS))(Robinson, Annette) (Entered: 10/01/2014)
10/02/2014	<u>31</u> (1 pg)	Order to Modify Plan (emccarty) (Entered: 10/02/2014)
10/16/2014	<u>32</u> (6 pgs)	Trustee's Summary Notice of Claims Filed (emccarty) (Entered: 10/16/2014)
10/23/2014	<u>33</u> (6 pgs; 2 docs)	Notice of Opportunity to Object/Respond to Plan AND Certificate of Service., Chapter 13 AMENDED Plan With Notice of Opportunity to Object/Respond Filed by G. Mike DeLoache on behalf of Joint Debtor Donna Mooney, Debtor Randy Mooney (Attachments: # <u>1</u> Creditor Matrix) (DeLoache, G.) (Entered: 10/23/2014)
10/23/2014	<u>34</u> (2 pgs)	Amended Schedules/Statements Filed: Schedule I, [Fee Due No] Filed by G. Mike DeLoache on behalf

EXHIBIT 4 4 BANKRUPTCY SEARCH		of Joint Debtor Donna Mooney, Debtor Randy Mooney (DeLoache, G.) (Entered: 10/23/2014)
10/23/2014	<u>35</u> (7 pgs)	Chapter 13 Statement of Current Monthly and Disposable Income -(Form 22C) Filed by G. Mike DeLoache on behalf of Joint Debtor Donna Mooney, Debtor Randy Mooney (DeLoache, G.) (Entered: 10/23/2014)
11/14/2014	<u>36</u> (1 pg)	Order Confirming Chapter 13 Plan (emccarty) (Entered: 11/14/2014)
11/16/2014	<u>37</u> (2 pgs)	BNC Certificate of Mailing(RE: related document(s) <u>36</u> Order Confirming Chapter 13 Plan (emccarty)) No. of Notices: 1. Notice Date 11/16/2014. (Admin.) (Entered: 11/16/2014)
03/05/2015	<u>38</u> (36 pgs; 2 docs)	Motion for Relief from Stay .Fee Amount \$176 Filed by John Randal Roan on behalf of Wells Fargo Bank, N.A. (Attachments: # <u>1</u> Executed Affidavit) (Roan, John) (Entered: 03/05/2015)
03/05/2015	39	RECEIPT of Motion for Relief From Stay(3:14-bk-11733) [motion,mrlfsty] (176.00) Filing Fee. receipt number 10394404, amount \$ 176.00. (U.S. Treasury) (Entered: 03/05/2015)
03/08/2015	<u>40</u> (2 pgs; 2 docs)	Hearing SCHEDULED(RE: related document(s) <u>38</u> Motion for Relief from Stay . Filed by John Randal Roan on behalf of Wells Fargo Bank, N.A.) Hearing scheduled for 4/9/2015 at 09:30 AM at Jonesboro Division. (Mansfield, MaryBeth) (Entered: 03/08/2015)
03/11/2015	<u>41</u> (2 pgs)	BNC Certificate of Mailing - Hearing(RE: related document(s) <u>40</u> Hearing SCHEDULED(RE: related document(s) <u>38</u> Motion for Relief from Stay . Filed by John Randal Roan on behalf of Wells Fargo Bank, N.A.) Hearing scheduled for 4/9/2015 at 09:30 AM at Jonesboro Division.) No. of Notices: 2. Notice Date 03/11/2015. (Admin.) (Entered: 03/11/2015)
03/24/2015	<u>doc</u> (6 pgs)	Notice of Mortgage Payment Change (Claim # 25) with Certificate of Service Filed by Wells Fargo Bank, N.A. (Phuse, Corey) (Entered: 03/24/2015)
04/08/2015	42	

Exhibit 4 4	EXHIBIT 4 4 BANKRUPTCY SEARCH	Hearing Scheduled For 4/9/15 Not Held. PER EMAIL FROM ROAN; GRANTED, HE WILL SUBMIT ORDER (RE: related document(s) <u>38</u> Motion for Relief from Stay . Filed by John Randal Roan on behalf of Wells Fargo Bank, N.A.) (Mansfield, MaryBeth) (Entered: 04/08/2015)
04/29/2015	<u>43</u> (3 pgs; 2 docs)	Order Granting Motion For Relief From Stay. (Related Doc # <u>38</u>) Entered on Docket 4/29/2015 (Robinson, Annette) (Entered: 04/29/2015)
05/01/2015	<u>44</u> (3 pgs)	BNC Certificate of Mailing(RE: related document(s) <u>43</u> Order Granting Motion For Relief From Stay. (Related Doc <u>38</u>) Entered on Docket 4/29/2015 (Robinson, Annette)) No. of Notices: 2. Notice Date 05/01/2015. (Admin.) (Entered: 05/01/2015)
02/16/2016	<u>doc</u> (6 pgs)	Notice of Mortgage Payment Change (Claim # 25) with Certificate of Service Filed by Wells Fargo Bank, N.A. (Chandler, John) (Entered: 02/16/2016)
08/24/2016	<u>doc</u> (6 pgs)	Notice of Mortgage Payment Changes of Claim No. 25 filed by Wells Fargo Bank N.A. (Entered: 08/24/2016)
08/26/2016	<u>45</u> (3 pgs; 3 docs)	Transfer/Assignment of Claim Transfer Agreement 3001 (e) 2 Transferor: Citibank, N.A. (Claim No. 24) To Quantum3 Group LLC as agent for Fee Amount \$25 Filed by (Sandhu, Dhar) (Entered: 08/26/2016)
08/26/2016	46	RECEIPT of Transfer of Claim(3:14-bk-11733) [claims,trclm] (25.00) Filing Fee. receipt number 11449727, amount \$ 25.00. (U.S. Treasury) (Entered: 08/26/2016)
08/28/2016	<u>47</u> (2 pgs)	BNC Certificate of Mailing(RE: related document(s) <u>45</u> Transfer/Assignment of Claim Transfer Agreement 3001 (e) 2 Transferor: Citibank, N.A. (Claim No. 24) To Quantum3 Group LLC as agent for Fee Amount \$25 Filed by) No. of Notices: 1. Notice Date 08/28/2016. (Admin.) (Entered: 08/28/2016)
06/14/2017	<u>doc</u> (6 pgs)	Notice of Mortgage Payment Changes of Claim No. 25 filed by Wells Fargo Bank N.A. (Entered: 06/14/2017)

EXHIBIT 4 4 BANKRUPTCY SEARCH

PACER Service Center			
Transaction Receipt			
07/19/2017 15:09:36			
PACER Login:	mc0019:2593428:0	Client Code:	
Description:	Docket Report	Search Criteria:	3:14-bk-11733 Fil or Ent: filed From: 1/1/1980 To: 7/19/2017 Doc From: 0 Doc To: 99999999 Term: included Format: html Page counts for documents: included
Billable Pages:	4	Cost:	0.40



Search Results

LEAH ROVNAGHI
Friday Eldredge & Clark
400 West Capitol Avenue
Suite 2000
Little Rock, AR 72201

Date: 07/21/2017
Order #: 59842764
Customer #: 504120
Reference 1: USBC / AR
Reference 2: --

Target Name: Mooney, Donna

Jurisdiction: U.S. Bankruptcy Court, Arkansas Western District

Search Type: Bankruptcy - Searched as Petitioner
Results: No Records Found

Searched Through: 07/14/2017
Searched: 10 Years
Office: Western District

BRIAN H. LEFEVRE
Chicago Team 1
208 S. LaSalle Street
Suite 814
Chicago, IL 60604
(888) 829-5817 Ext.3582
Brian.LeFevre@wolterskluwer.com

This report contains information compiled from sources which CT Lien Solutions considers reliable but does not control. The information provided is not a certified record of the applicable jurisdiction unless otherwise indicated. CT Lien Solutions does not (i) warrant or guarantee the accuracy, completion or timeliness of the information provided or (ii) accept any liability for delays, errors or omissions in the information provided. CT Lien Solutions is not an insurer with regard to this information or these services. Under no circumstances shall CT Lien Solutions be liable for any loss of underlying collateral or loss (or decreased priority) of security interest in connection with this information or these services. Any categorization of search results is provided for convenience only and is not to be construed as a legal opinion concerning the status of filings.

Search Results

LEAH ROVNAGHI
Friday Eldredge & Clark
400 West Capitol Avenue
Suite 2000
Little Rock, AR 72201

Date: 07/21/2017
Order #: 59842764
Customer #: 504120
Reference 1: USBC / AR
Reference 2: --

Target Name: Terrell, Donna

Jurisdiction: U.S. Bankruptcy Court, Arkansas Eastern District

Search Type: Bankruptcy - Searched as Petitioner
Results: No Records Found

Searched Through: 07/14/2017
Searched: 10 Years
Office: Eastern District

BRIAN H. LEFEVRE
Chicago Team 1
208 S. LaSalle Street
Suite 814
Chicago, IL 60604
(888) 829-5817 Ext.3582
Brian.LeFevre@wolterskluwer.com

This report contains information compiled from sources which CT Lien Solutions considers reliable but does not control. The information provided is not a certified record of the applicable jurisdiction unless otherwise indicated. CT Lien Solutions does not (i) warrant or guarantee the accuracy, completion or timeliness of the information provided or (ii) accept any liability for delays, errors or omissions in the information provided. CT Lien Solutions is not an insurer with regard to this information or these services. Under no circumstances shall CT Lien Solutions be liable for any loss of underlying collateral or loss (or decreased priority) of security interest in connection with this information or these services. Any categorization of search results is provided for convenience only and is not to be construed as a legal opinion concerning the status of filings.



Search Results

LEAH ROVNAGHI
Friday Eldredge & Clark
400 West Capitol Avenue
Suite 2000
Little Rock, AR 72201

Date: 07/21/2017
Order #: 59842764
Customer #: 504120
Reference 1: USBC / AR
Reference 2: --

Target Name: Terrell, Donna

Jurisdiction: U.S. Bankruptcy Court, Arkansas Western District

Search Type: Bankruptcy - Searched as Petitioner
Results: No Records Found

Searched Through: 07/14/2017
Searched: 10 Years
Office: Western District

BRIAN H. LEFEVRE
Chicago Team 1
208 S. LaSalle Street
Suite 814
Chicago, IL 60604
(888) 829-5817 Ext.3582
Brian.LeFevre@wolterskluwer.com

This report contains information compiled from sources which CT Lien Solutions considers reliable but does not control. The information provided is not a certified record of the applicable jurisdiction unless otherwise indicated. CT Lien Solutions does not (i) warrant or guarantee the accuracy, completion or timeliness of the information provided or (ii) accept any liability for delays, errors or omissions in the information provided. CT Lien Solutions is not an insurer with regard to this information or these services. Under no circumstances shall CT Lien Solutions be liable for any loss of underlying collateral or loss (or decreased priority) of security interest in connection with this information or these services. Any categorization of search results is provided for convenience only and is not to be construed as a legal opinion concerning the status of filings.



CT Lien Solutions

a Wolters Kluwer Business

Search Results

LEAH ROVNAGHI
Friday Eldredge & Clark
400 West Capitol Avenue
Suite 2000
Little Rock, AR 72201

Date: 07/21/2017
Order #: 59842764
Customer #: 504120
Reference 1: USBC / AR
Reference 2: --

Target Name: Courtright, Joe

Jurisdiction: U.S. Bankruptcy Court, Arkansas Eastern District

Search Type: Bankruptcy - Searched as Petitioner

Results: No Records Found

Searched Through: 07/14/2017

Searched: 10 Years

Office: Eastern District

BRIAN H. LEFEVRE
Chicago Team 1
208 S. LaSalle Street
Suite 814
Chicago, IL 60604
(888) 829-5817 Ext. 3582
Brian.LeFevre@wolterskluwer.com

This report contains information compiled from sources which CT Lien Solutions considers reliable but does not control. The information provided is not a certified record of the applicable jurisdiction unless otherwise indicated. CT Lien Solutions does not (i) warrant or guarantee the accuracy, completion or timeliness of the information provided or (ii) accept any liability for delays, errors or omissions in the information provided. CT Lien Solutions is not an insurer with regard to this information or these services. Under no circumstances shall CT Lien Solutions be liable for any loss of underlying collateral or loss (or decreased priority) of security interest in connection with this information or these services. Any categorization of search results is provided for convenience only and is not to be construed as a legal opinion concerning the status of filings.



CT Lien Solutions

a Wolters Kluwer Business

Search Results

LEAH ROVNAGHI
Friday Eldredge & Clark
400 West Capitol Avenue
Suite 2000
Little Rock, AR 72201

Date: 07/21/2017
Order #: 59842764
Customer #: 504120
Reference 1: USBC / AR
Reference 2: --

Target Name: Courtright, Joe

Jurisdiction: U.S. Bankruptcy Court, Arkansas Western District

Search Type: Bankruptcy - Searched as Petitioner
Results: No Records Found

Searched Through: 07/14/2017
Searched: 10 Years
Office: Western District

BRIAN H. LEFEVRE
Chicago Team 1
208 S. LaSalle Street
Suite 814
Chicago, IL 60604
(888) 829-5817 Ext.3582
Brian.LeFevre@wolterskluwer.com

This report contains information compiled from sources which CT Lien Solutions considers reliable but does not control. The information provided is not a certified record of the applicable jurisdiction unless otherwise indicated. CT Lien Solutions does not (i) warrant or guarantee the accuracy, completion or timeliness of the information provided or (ii) accept any liability for delays, errors or omissions in the information provided. CT Lien Solutions is not an insurer with regard to this information or these services. Under no circumstances shall CT Lien Solutions be liable for any loss of underlying collateral or loss (or decreased priority) of security interest in connection with this information or these services. Any categorization of search results is provided for convenience only and is not to be construed as a legal opinion concerning the status of filings.

Search Results

LEAH ROVNAGHI
Friday Eldredge & Clark
400 West Capitol Avenue
Suite 2000
Little Rock, AR 72201

Date: 07/21/2017
Order #: 59842764
Customer #: 504120
Reference 1: USBC / AR
Reference 2: --

Target Name: Mooney, Keith

Jurisdiction: U.S. Bankruptcy Court, Arkansas Eastern District

Search Type: Bankruptcy - Searched as Petitioner
Results: No Records Found

Searched Through: 07/14/2017
Searched: 10 Years
Office: Eastern District

BRIAN H. LEFEVRE
Chicago Team 1
208 S. LaSalle Street
Suite 814
Chicago, IL 60604
(888) 829-5817 Ext.3582
Brian.LeFevre@wolterskluwer.com

This report contains information compiled from sources which CT Lien Solutions considers reliable but does not control. The information provided is not a certified record of the applicable jurisdiction unless otherwise indicated. CT Lien Solutions does not (i) warrant or guarantee the accuracy, completion or timeliness of the information provided or (ii) accept any liability for delays, errors or omissions in the information provided. CT Lien Solutions is not an insurer with regard to this information or these services. Under no circumstances shall CT Lien Solutions be liable for any loss of underlying collateral or loss (or decreased priority) of security interest in connection with this information or these services. Any categorization of search results is provided for convenience only and is not to be construed as a legal opinion concerning the status of filings.



Search Results

LEAH ROVNAGHI
Friday Eldredge & Clark
400 West Capitol Avenue
Suite 2000
Little Rock, AR 72201

Date: 07/21/2017
Order #: 59842764
Customer #: 504120
Reference 1: USBC / AR
Reference 2: --

Target Name: **Mooney, Keith**

Jurisdiction: **U.S. Bankruptcy Court, Arkansas Western District**

Search Type: **Bankruptcy - Searched as Petitioner**

Results: No Records Found

Searched Through: **07/14/2017**

Searched: 10 Years

Office: Western District

BRIAN H. LEFEVRE
Chicago Team 1
208 S. LaSalle Street
Suite 814
Chicago, IL 60604
(888) 829-5817 Ext.3582
Brian.LeFevre@wolterskluwer.com

This report contains information compiled from sources which CT Lien Solutions considers reliable but does not control. The information provided is not a certified record of the applicable jurisdiction unless otherwise indicated. CT Lien Solutions does not (i) warrant or guarantee the accuracy, completion or timeliness of the information provided or (ii) accept any liability for delays, errors or omissions in the information provided. CT Lien Solutions is not an insurer with regard to this information or these services. Under no circumstances shall CT Lien Solutions be liable for any loss of underlying collateral or loss (or decreased priority) of security interest in connection with this information or these services. Any categorization of search results is provided for convenience only and is not to be construed as a legal opinion concerning the status of filings.

Search Results

LEAH ROVNAGHI
Friday Eldredge & Clark
400 West Capitol Avenue
Suite 2000
Little Rock, AR 72201

Date: 07/21/2017
Order #: 59842764
Customer #: 504120
Reference 1: USBC / AR
Reference 2: --

Target Name: Schlesinger, Kelly

Jurisdiction: U.S. Bankruptcy Court, Arkansas Eastern District

Search Type: Bankruptcy - Searched as Petitioner
Results: No Records Found

Searched Through: 07/14/2017
Searched: 10 Years
Office: Eastern District

BRIAN H. LEFEVRE
Chicago Team 1
208 S. LaSalle Street
Suite 814
Chicago, IL 60604
(888) 829-5817 Ext.3582
Brian.LeFevre@wolterskluwer.com

This report contains information compiled from sources which CT Lien Solutions considers reliable but does not control. The information provided is not a certified record of the applicable jurisdiction unless otherwise indicated. CT Lien Solutions does not (i) warrant or guarantee the accuracy, completion or timeliness of the information provided or (ii) accept any liability for delays, errors or omissions in the information provided. CT Lien Solutions is not an insurer with regard to this information or these services. Under no circumstances shall CT Lien Solutions be liable for any loss of underlying collateral or loss (or decreased priority) of security interest in connection with this information or these services. Any categorization of search results is provided for convenience only and is not to be construed as a legal opinion concerning the status of filings.



a Wolters Kluwer Business

Search Results

LEAH ROVNAGHI
Friday Eldredge & Clark
400 West Capitol Avenue
Suite 2000
Little Rock, AR 72201

Date: 07/21/2017
Order #: 59842764
Customer #: 504120
Reference 1: USBC / AR
Reference 2: --

Target Name: Schlesinger, Kelly

Jurisdiction: U.S. Bankruptcy Court, Arkansas Western District

Search Type: Bankruptcy - Searched as Petitioner
Results: No Records Found

Searched Through: 07/14/2017
Searched: 10 Years
Office: Western District

BRIAN H. LEFEVRE
Chicago Team 1
208 S. LaSalle Street
Suite 814
Chicago, IL 60604
(888) 829-5817 Ext.3582
Brian.LeFevre@wolterskluwer.com

This report contains information compiled from sources which CT Lien Solutions considers reliable but does not control. The information provided is not a certified record of the applicable jurisdiction unless otherwise indicated. CT Lien Solutions does not (i) warrant or guarantee the accuracy, completion or timeliness of the information provided or (ii) accept any liability for delays, errors or omissions in the information provided. CT Lien Solutions is not an insurer with regard to this information or these services. Under no circumstances shall CT Lien Solutions be liable for any loss of underlying collateral or loss (or decreased priority) of security interest in connection with this information or these services. Any categorization of search results is provided for convenience only and is not to be construed as a legal opinion concerning the status of filings.



Search Results

LEAH ROVNAGHI
Friday Eldredge & Clark
400 West Capitol Avenue
Suite 2000
Little Rock, AR 72201

Date: 07/21/2017
Order #: 59842764
Customer #: 504120
Reference 1: USBC / AR
Reference 2: --

Target Name: Debin, Robert

Jurisdiction: U.S. Bankruptcy Court, Arkansas Eastern District

Search Type: Bankruptcy - Searched as Petitioner
Results: No Records Found

Searched Through: 07/14/2017
Searched: 10 Years
Office: Eastern District

BRIAN H. LEFEVRE
Chicago Team 1
208 S. LaSalle Street
Suite 814
Chicago, IL 60604
(888) 829-5817 Ext.3582
Brian.LeFevre@wolterskluwer.com

This report contains information compiled from sources which CT Lien Solutions considers reliable but does not control. The information provided is not a certified record of the applicable jurisdiction unless otherwise indicated. CT Lien Solutions does not (i) warrant or guarantee the accuracy, completion or timeliness of the information provided or (ii) accept any liability for delays, errors or omissions in the information provided. CT Lien Solutions is not an insurer with regard to this information or these services. Under no circumstances shall CT Lien Solutions be liable for any loss of underlying collateral or loss (or decreased priority) of security interest in connection with this information or these services. Any categorization of search results is provided for convenience only and is not to be construed as a legal opinion concerning the status of filings.



Search Results

LEAH ROVNAGHI
Friday Eldredge & Clark
400 West Capitol Avenue
Suite 2000
Little Rock, AR 72201

Date: 07/21/2017
Order #: 59842764
Customer #: 504120
Reference 1: USBC / AR
Reference 2: --

Target Name: Debin, Robert

Jurisdiction: U.S. Bankruptcy Court, Arkansas Western District

Search Type: Bankruptcy - Searched as Petitioner
Results: No Records Found

Searched Through: 07/14/2017
Searched: 10 Years
Office: Western District

BRIAN H. LEFEVRE
Chicago Team 1
208 S. LaSalle Street
Suite 814
Chicago, IL 60604
(888) 829-5817 Ext.3582
Brian.LeFevre@wolterskluwer.com

This report contains information compiled from sources which CT Lien Solutions considers reliable but does not control. The information provided is not a certified record of the applicable jurisdiction unless otherwise indicated. CT Lien Solutions does not (i) warrant or guarantee the accuracy, completion or timeliness of the information provided or (ii) accept any liability for delays, errors or omissions in the information provided. CT Lien Solutions is not an insurer with regard to this information or these services. Under no circumstances shall CT Lien Solutions be liable for any loss of underlying collateral or loss (or decreased priority) of security interest in connection with this information or these services. Any categorization of search results is provided for convenience only and is not to be construed as a legal opinion concerning the status of filings.

AFFIDAVIT

STATE OF ARKANSAS
COUNTY OF PULASKI

KNOW ALL PERSONS BY THESE PRESENTS:

Before the undersigned notary public, duly qualified and acting in and for said county and state, personally appeared Susan D. Williams to me well known or satisfactorily proven to be the affiant herein, who, after being duly sworn, stated the following under oath:

1. My name is Susan D. Williams and I currently reside at [REDACTED]

2. I have never filed bankruptcy under any federal or state law, and no proceedings in bankruptcy have ever been instituted by or against me in any U.S. Bankruptcy court or any bankruptcy court of any state or other jurisdiction.

3. I have neither owned nor operated an entity that has filed bankruptcy under any federal or state law, and no proceedings in bankruptcy have ever been instituted by or against any entity owned or operated by me in any U.S Bankruptcy court or any bankruptcy court of any state or other jurisdiction.

4. I am not the same Susan D. Miller named as debtor in Bankruptcy Petition # 4:08-bk-11388 filed in the U.S. Bankruptcy Court, Eastern District of Arkansas.

5. The last four digits of my social security number are not 1526.

I have read the foregoing statements and they are true and correct to the best of my knowledge and belief.

[Remainder of page intentionally left blank; signature page follows.]

EXHIBIT 4 4 BANKRUPTCY SEARCH

IN WITNESS WHEREOF, I hereunto set my hand this 22 day of August, 2017.

AFFIANT:

Susan D. Williams

Susan D. Williams

Subscribed and sworn to before me this 22 day of August, 2017.

Kathryn B. Carnes
Notary Public

My Commission Expires:

10/20/20





Search Results

LEAH ROVNAGHI
Friday Eldredge & Clark
400 West Capitol Avenue
Suite 2000
Little Rock, AR 72201

Date: 07/21/2017
Order #: 59842764
Customer #: 504120
Reference 1: USBC / AR
Reference 2: --

Target Name: Schlesinger, Scott

Jurisdiction: U.S. Bankruptcy Court, Arkansas Eastern District

Search Type: Bankruptcy - Searched as Petitioner
Results: No Records Found

Searched Through: 07/14/2017
Searched: 10 Years
Office: Eastern District

BRIAN H. LEFEVRE
Chicago Team 1
208 S. LaSalle Street
Suite 814
Chicago, IL 60604
(888) 829-5817 Ext.3582
Brian.LeFevre@wolterskluwer.com

This report contains information compiled from sources which CT Lien Solutions considers reliable but does not control. The information provided is not a certified record of the applicable jurisdiction unless otherwise indicated. CT Lien Solutions does not (i) warrant or guarantee the accuracy, completion or timeliness of the information provided or (ii) accept any liability for delays, errors or omissions in the information provided. CT Lien Solutions is not an insurer with regard to this information or these services. Under no circumstances shall CT Lien Solutions be liable for any loss of underlying collateral or loss (or decreased priority) of security interest in connection with this information or these services. Any categorization of search results is provided for convenience only and is not to be construed as a legal opinion concerning the status of filings.



Search Results

LEAH ROVNAGHI
Friday Eldredge & Clark
400 West Capitol Avenue
Suite 2000
Little Rock, AR 72201

Date: 07/21/2017
Order #: 59842764
Customer #: 504120
Reference 1: USBC / AR
Reference 2: --

Target Name: Schlesinger, Scott

Jurisdiction: U.S. Bankruptcy Court, Arkansas Western District

Search Type: Bankruptcy - Searched as Petitioner
Results: No Records Found

Searched Through: 07/14/2017
Searched: 10 Years
Office: Western District

BRIAN H. LEFEVRE
Chicago Team 1
208 S. LaSalle Street
Suite 814
Chicago, IL 60604
(888) 829-5817 Ext.3582
Brian.LeFevre@wolterskluwer.com

This report contains information compiled from sources which CT Lien Solutions considers reliable but does not control. The information provided is not a certified record of the applicable jurisdiction unless otherwise indicated. CT Lien Solutions does not (i) warrant or guarantee the accuracy, completion or timeliness of the information provided or (ii) accept any liability for delays, errors or omissions in the information provided. CT Lien Solutions is not an insurer with regard to this information or these services. Under no circumstances shall CT Lien Solutions be liable for any loss of underlying collateral or loss (or decreased priority) of security interest in connection with this information or these services. Any categorization of search results is provided for convenience only and is not to be construed as a legal opinion concerning the status of filings.

Search Results

LEAH ROVNAGHI
Friday Eldredge & Clark
400 West Capitol Avenue
Suite 2000
Little Rock, AR 72201

Date: 07/21/2017
Order #: 59842764
Customer #: 504120
Reference 1: USBC / AR
Reference 2: --

Target Name: Lafrance, Stephen

Jurisdiction: U.S. Bankruptcy Court, Arkansas Eastern District

Search Type: Bankruptcy - Searched as Petitioner
Results: No Records Found

Searched Through: 07/14/2017
Searched: 10 Years
Office: Eastern District

BRIAN H. LEFEVRE
Chicago Team 1
208 S. LaSalle Street
Suite 814
Chicago, IL 60604
(888) 829-5817 Ext.3582
Brian.LeFevre@wolterskluwer.com

This report contains information compiled from sources which CT Lien Solutions considers reliable but does not control. The information provided is not a certified record of the applicable jurisdiction unless otherwise indicated. CT Lien Solutions does not (i) warrant or guarantee the accuracy, completion or timeliness of the information provided or (ii) accept any liability for delays, errors or omissions in the information provided. CT Lien Solutions is not an insurer with regard to this information or these services. Under no circumstances shall CT Lien Solutions be liable for any loss of underlying collateral or loss (or decreased priority) of security interest in connection with this information or these services. Any categorization of search results is provided for convenience only and is not to be construed as a legal opinion concerning the status of filings.

Search Results

LEAH ROVNAGHI
Friday Eldredge & Clark
400 West Capitol Avenue
Suite 2000
Little Rock, AR 72201

Date: 07/21/2017
Order #: 59842764
Customer #: 504120
Reference 1: USBC / AR
Reference 2: --

Target Name: Lafrance, Stephen

Jurisdiction: U.S. Bankruptcy Court, Arkansas Western District

Search Type: Bankruptcy - Searched as Petitioner
Results: No Records Found

Searched Through: 07/14/2017
Searched: 10 Years
Office: Western District

BRIAN H. LEFEVRE
Chicago Team 1
208 S. LaSalle Street
Suite 814
Chicago, IL 60604
(888) 829-5817 Ext.3582
Brian.LeFevre@wolterskluwer.com

This report contains information compiled from sources which CT Lien Solutions considers reliable but does not control. The information provided is not a certified record of the applicable jurisdiction unless otherwise indicated. CT Lien Solutions does not (i) warrant or guarantee the accuracy, completion or timeliness of the information provided or (ii) accept any liability for delays, errors or omissions in the information provided. CT Lien Solutions is not an insurer with regard to this information or these services. Under no circumstances shall CT Lien Solutions be liable for any loss of underlying collateral or loss (or decreased priority) of security interest in connection with this information or these services. Any categorization of search results is provided for convenience only and is not to be construed as a legal opinion concerning the status of filings.

Search Results

LEAH ROVNAGHI
Friday Eldredge & Clark
400 West Capitol Avenue
Suite 2000
Little Rock, AR 72201

Date: 07/21/2017
Order #: 59842764
Customer #: 504120
Reference 1: USBC / AR
Reference 2: --

Target Name: Williams, Susan D

Jurisdiction: U.S. Bankruptcy Court, Arkansas Eastern District

Search Type: Bankruptcy - Searched as Petitioner

Searched Through: 07/14/2017

Results: See Attached Listing of Records Found with 13 Copies
Attached

Searched: 10 Years

Office: Eastern District

Document Listing:

File #	File Date	Chapter Type
08-bk-11388	03/03/2008	Chapter 13

BRIAN H. LEFEVRE
Chicago Team 1
208 S. LaSalle Street
Suite 814
Chicago, IL 60604
(888) 829-5817 Ext. 3582
Brian.LeFevre@wolterskluwer.com

This report contains information compiled from sources which CT Lien Solutions considers reliable but does not control. The information provided is not a certified record of the applicable jurisdiction unless otherwise indicated. CT Lien Solutions does not (i) warrant or guarantee the accuracy, completion or timeliness of the information provided or (ii) accept any liability for delays, errors or omissions in the information provided. CT Lien Solutions is not an insurer with regard to this information or these services. Under no circumstances shall CT Lien Solutions be liable for any loss of underlying collateral or loss (or decreased priority) of security interest in connection with this information or these services. Any categorization of search results is provided for convenience only and is not to be construed as a legal opinion concerning the status of filings.

MDSM, CLOSED

**U.S. Bankruptcy Court
Eastern District of Arkansas (Little Rock)
Bankruptcy Petition #: 4:08-bk-11388**

Assigned to: Judge Richard D. Taylor
Chapter 13
Voluntary
Asset

Date filed: 03/03/2008
Date terminated: 08/30/2013
Debtor discharged: 06/11/2013
Joint debtor discharged: 06/11/2013
Plan confirmed: 05/01/2013

Debtor disposition: Standard Discharge
Joint debtor disposition: Standard Discharge

Debtor

John S. Miller
7905 North Ridge Road
Mabelvale, AR 72103
SALINE-AR
SSN / ITIN: xxx-xx-0850

represented by **Robert R. Danecki**
Attorney at Law
P.O. Box 1938
Little Rock, AR 72203-1938
(501) 371-0002[Ⓟ]
Fax : (866) 341-7654[Ⓟ]
Email: Robert@danecki.com

Joint Debtor

Susan D. Miller
7905 North Ridge Road
Mabelvale, AR 72103
SALINE-AR
SSN / ITIN: xxx-xx-1526
aka Susan D. Williams

represented by **Robert R. Danecki**
(See above for address)

Trustee

David D. Coop
U.S. Bankruptcy Trustee
P.O. Box 5006
N. Little Rock, AR 72119-5006
(501) 374-1572[Ⓟ]
TERMINATED: 05/01/2008

Trustee

Mark T. McCarty
Chapter 13 Standing Trustee
P.O. Box 5006
N. Little Rock, AR 72119-5006
501-374-1572[Ⓟ]

Exhibit 4 4
 U.S. Trustee

EXHIBIT 4 4 BANKRUPTCY SEARCH

U.S. Trustee (ust)
 Office of U.S. Trustee
 200 W Capitol, Ste. 1200
 Little Rock, AR 72201
 501-324-7357

Filing Date	#	Docket Text
03/03/2008	<u>1</u> (49 pgs)	Chapter 13 Voluntary Petition. Fee Amount \$274 Filed by John S. Miller, Susan D. Miller. (Danecki, Robert) (Entered: 03/03/2008)
03/03/2008	<u>2</u> (5 pgs)	Chapter 13 Plan With Notice of Opportunity to Object/Respond Filed by Robert R. Danecki on behalf of Debtor John S. Miller, Joint Debtor Susan D. Miller. Plan Completion Due Date Set 2/5/2013. (Danecki, Robert) (Entered: 03/03/2008)
03/03/2008	<u>3</u> (1 pg)	Certificate of Credit Counseling Filed by Robert R. Danecki on behalf of Debtor John S. Miller (Danecki, Robert) (Entered: 03/03/2008)
03/03/2008	<u>4</u> (1 pg)	Certificate of Credit Counseling Filed by Robert R. Danecki on behalf of Joint Debtor Susan D. Miller (Danecki, Robert) (Entered: 03/03/2008)
03/03/2008	5	RECEIPT of Voluntary Petition (Chapter 13)(4:08-bk-11388) [misc,volp13a] (274.00) Filing Fee. receipt number 4711646, amount \$ 274.00. (U.S. Treasury) (Entered: 03/03/2008)
03/03/2008	<u>6</u> (1 pg)	Application for Compensation Filed by Robert R. Danecki on behalf of John S. Miller, Susan D. Miller (Danecki, Robert) (Entered: 03/03/2008)
03/04/2008	<u>7</u> (2 pgs)	Meeting of Creditors 341(a) meeting to be held on 4/2/2008 at 01:30 PM at U.S. Trustee's Office Meeting Room. Last day to oppose to dischargeability is 6/2/2008. Proofs of Claims due by 7/1/2008. (McGinness, Stephanie) (Entered: 03/04/2008)
03/04/2008	<u>8</u> (1 pg)	Order to Pay Trustee. (ecoop,) (Entered: 03/04/2008)
03/07/2008		

Exhibit 4 4

EXHIBIT 4 4 BANKRUPTCY SEARCH

	<u>9</u> (5 pgs)	BNC Certificate of Mailing - Meeting of Creditors (RE: related document(s) <u>7</u> Meeting of Creditors Chapter 13) No. of Notices: 12. Service Date 03/07/2008. (Admin.) (Entered: 03/08/2008)
03/14/2008	<u>10</u> (1 pg)	Order on Application For Compensation Ch. 13. (ecoop,) (Entered: 03/14/2008)
03/15/2008	<u>11</u> (1 pg)	Notice of Appearance and Request for Notice filed by Bryan Parker Christian Creditor Ford Motor Credit Company LLC. (Christian, Bryan) (Entered: 03/15/2008)
03/15/2008	<u>12</u> (1 pg)	Motion for Relief from Stay and Motion for Relief from Co-Debtor Stay Re: Co-Debtor Stacie Jackson .Fee Amount \$150 Filed by Bryan Parker Christian on behalf of Ford Motor Credit Company LLC (Christian, Bryan) (Entered: 03/15/2008)
03/15/2008	13	RECEIPT of Motion for Relief From Stay(4:08-bk-11388) [motion,mrlfsty] (150.00) Filing Fee. receipt number 4736481, amount \$ 150.00. (U.S. Treasury) (Entered: 03/15/2008)
03/18/2008	<u>14</u> (1 pg)	Hearing Scheduled, (RE: related document(s) <u>12</u> Motion for Relief From Stay filed by Creditor Ford Motor Credit Company LLC). Hearing scheduled for 4/16/2008 at 09:00 AM at Judge Taylor's Little Rock Courtroom. (Parrish, Marie) (Entered: 03/18/2008)
03/19/2008	<u>15</u> (2 pgs)	BNC Certificate of Mailing(RE: related document(s) <u>10</u> Order on Compensation) No. of Notices: 3. Service Date 03/19/2008. (Admin.) (Entered: 03/20/2008)
03/20/2008	<u>16</u> (2 pgs)	BNC Certificate of Mailing - Hearing(RE: related document(s) <u>14</u> Hearing (Document) Sched/Cont/Resched) No. of Notices: 4. Service Date 03/20/2008. (Admin.) (Entered: 03/21/2008)
04/01/2008	17	Request by Household Bank (SB), N.A. Designating Mailing Address for Notices pursuant to Bankruptcy Rule 2002(g)(1), requesting service of copies of all future notices at the address specified in the process of filing this Request Filed by (Bass, Patti) (Entered: 04/01/2008)
04/07/2008	18	

Exhibit 4 4

EXHIBIT 4 4 BANKRUPTCY SEARCH

		Meeting of Creditors Held and Concluded on 04/02/2008. Filed by Trustee (Wortham, Susie) (Entered: 04/07/2008)
04/08/2008	<u>19</u> (1 pg)	Notice of Appearance and Request for Notice filed by Doralee I Chandler Creditor Origen Financial, LLC. (Chandler, Doralee) (Entered: 04/08/2008)
04/09/2008	<u>20</u> (4 pgs; 2 docs)	Agreed Order of Abandonment of 1997 Sunshine 16x80 Manufactured Home Entered on 4/9/2008 (Miller, Shari) (Entered: 04/09/2008)
04/11/2008	<u>21</u> (4 pgs)	BNC Certificate of Mailing(RE: related document(s) <u>20</u> Order to Abandon or Surrender) No. of Notices: 1. Service Date 04/11/2008. (Admin.) (Entered: 04/12/2008)
04/16/2008	<u>22</u> (2 pgs; 2 docs)	Order Granting Motion For Relief From Stay and From Co-Debtor (Stacie Jackson) Stay filed by Ford Motor Credit Company, LLC. (Related Doc # <u>12</u>) Entered on Docket 4/16/2008 (Miller, Shari) (Entered: 04/16/2008)
04/17/2008	<u>23</u> (1 pg)	Order Confirming Chapter 13 Plan. (ecoop,) (Entered: 04/17/2008)
04/18/2008	<u>24</u> (2 pgs)	BNC Certificate of Mailing(RE: related document(s) <u>22</u> Order on Motion For Relief From Stay) No. of Notices: 3. Service Date 04/18/2008. (Admin.) (Entered: 04/19/2008)
04/20/2008	<u>25</u> (2 pgs)	BNC Certificate of Mailing(RE: related document(s) <u>23</u> Order Confirming Chapter 13 Plan) No. of Notices: 2. Service Date 04/20/2008. (Admin.) (Entered: 04/21/2008)
05/01/2008	<u>26</u> (2 pgs; 2 docs)	Notice of Appointment of Successor Trustee. Mark T. McCarty Appointed to Case. David D. Coop Terminated on Case. (ADI) (Entered: 05/01/2008)
05/02/2008	<u>27</u> (2 pgs)	Notice of Appearance and Request for Notice filed by Joe Manuel Lozano Creditor Kubota Credit Corporation. (Lozano, Joe) (Entered: 05/02/2008)
05/03/2008	<u>28</u> (2 pgs)	BNC Certificate of Mailing(RE: related document(s) <u>26</u> Notice Appointing Successor Trustee) No. of Notices: 2. Service Date 05/03/2008. (Admin.) (Entered: 05/04/2008)

Exhibit 4.4

EXHIBIT 4.4 BANKRUPTCY SEARCH

05/20/2008	<u>29</u> (3 pgs)	Chapter 13 MODIFIED Plan With Notice of Opportunity to Object/Respond Filed by Robert R. Danecki on behalf of Debtor John S. Miller, Joint Debtor Susan D. Miller (Danecki, Robert) (Entered: 05/20/2008)
05/20/2008	<u>30</u> (3 pgs)	Amended Schedules/Statements Filed: Schedule I, Schedule J, [Fee Due No] Filed by Robert R. Danecki on behalf of Debtor John S. Miller, Joint Debtor Susan D. Miller (Danecki, Robert) (Entered: 05/20/2008)
05/22/2008	<u>31</u> (1 pg)	Order to Pay Trustee. (ecoop,) (Entered: 05/22/2008)
06/04/2008	<u>32</u> (3 pgs; 2 docs)	Agreed Order Granting Relief From the Automatic Stay Re: 2006 Kawasaki Vulcan Entered on 6/4/2008(Miller, Shari) (Entered: 06/04/2008)
06/06/2008	<u>33</u> (1 pg)	Objection to Confirmation of Modified Plan Filed by Trustee. (ecoop,) (Entered: 06/06/2008)
06/10/2008	<u>34</u> (2 pgs; 2 docs)	Hearing Scheduled, (RE: related document(s) <u>33</u> Objection to Confirmation of Modified Plan Filed by Trustee). Hearing scheduled for 7/15/2008 at 09:00 AM at Judge Taylor's Little Rock Courtroom. (Parrish, Marie) (Entered: 06/10/2008)
06/12/2008	<u>35</u> (2 pgs)	BNC Certificate of Mailing - Hearing(RE: related document(s) <u>34</u> Hearing (Document) Sched/Cont/Resched) No. of Notices: 2. Service Date 06/12/2008. (Admin.) (Entered: 06/13/2008)
06/17/2008	<u>36</u> (9 pgs; 2 docs)	Motion for Relief from Stay <i>2004 Sunshine Mobile Home</i> . Fee Amount \$150 Filed by Doralee I Chandler on behalf of Origen Financial, LLC (Attachments: <u>1</u> Exhibit Retail Installment Contract and Title) (Chandler, Doralee) (Entered: 06/17/2008)
06/17/2008	<u>37</u>	RECEIPT of Motion for Relief From Stay(4:08-bk-11388) [motion,mrlfsty] (150.00) Filing Fee. receipt number 4929378, amount \$ 150.00. (U.S. Treasury) (Entered: 06/17/2008)
06/19/2008	<u>38</u> (2 pgs; 2 docs)	Hearing Scheduled, (RE: related document(s) <u>36</u> Motion for Relief From Stay filed by Creditor Origen Financial, LLC). Hearing scheduled for

Exhibit 4 4

EXHIBIT 4 4 BANKRUPTCY SEARCH

		7/15/2008 at 09:00 AM at Judge Taylor's Little Rock Courtroom. (Parrish, Marie) (Entered: 06/19/2008)
06/21/2008	<u>39</u> (2 pgs)	BNC Certificate of Mailing - Hearing(RE: related document(s) <u>38</u> Hearing (Document) Sched/Cont/Resched) No. of Notices: 2. Service Date 06/21/2008. (Admin.) (Entered: 06/22/2008)
06/24/2008	<u>40</u> (2 pgs; 2 docs)	Order Withdrawing Motion For Relief From Stay (Related Doc # <u>36</u>) Entered on Docket 6/24/2008 (Williams, Lisa) (Entered: 06/24/2008)
07/01/2008	<u>41</u> (3 pgs)	Chapter 13 MODIFIED Plan With Notice of Opportunity to Object/Respond Filed by Robert R. Danecki on behalf of Debtor John S. Miller, Joint Debtor Susan D. Miller (Danecki, Robert) (Entered: 07/01/2008)
07/07/2008	<u>42</u> (1 pg)	Trustee Motion to Withdraw Objection to Confirmation and Order Granting. (emccarty,) (Entered: 07/07/2008)
07/10/2008	<u>43</u> (1 pg)	Order to Pay Trustee. (emccarty,) (Entered: 07/10/2008)
07/15/2008	<u>44</u> (1 pg)	Objection to Confirmation of Modified Plan Filed by Trustee. (emccarty,) (Entered: 07/15/2008)
07/17/2008	<u>45</u> (2 pgs; 2 docs)	Hearing Scheduled, (RE: related document(s) <u>44</u> Objection to Confirmation of Modified Plan Filed by Trustee). Hearing scheduled for 8/6/2008 at 09:00 AM at Judge Taylor's Little Rock Courtroom. (Parrish, Marie) (Entered: 07/17/2008)
07/19/2008	<u>46</u> (4 pgs; 3 docs)	Transfer of Claim Transfer Agreement 3001 (e) 2 Transferor: HSBC Bank Nevada, N.A. (Claim No. 11) To eCAST Settlement Corporation Filed by (Bass, Patti) (Entered: 07/19/2008)
07/19/2008	<u>47</u> (2 pgs)	BNC Certificate of Mailing - Hearing(RE: related document(s) <u>45</u> Hearing (Document) Sched/Cont/Resched) No. of Notices: 2. Service Date 07/19/2008. (Admin.) (Entered: 07/20/2008)
07/23/2008	<u>48</u> (2 pgs)	BNC Certificate of Mailing(RE: related document(s) <u>46</u> Transfer of Claim) No. of Notices: 1. Service Date 07/23/2008. (Admin.) (Entered: 07/24/2008)

Exhibit 4 4 07/28/2008	EXHIBIT 4 4 BANKRUPTCY SEARCH <u>49</u> (1 pg)	Trustee Motion to Withdraw Objection to Confirmation and Order Granting. (emccarty,) (Entered: 07/28/2008)
07/29/2008	<u>50</u> (1 pg)	Order Confirming Modified Chapter 13 Plan. (emccarty,) (Entered: 07/29/2008)
07/30/2008	<u>51</u> (2 pgs)	Additional Application for Compensation Filed by Robert R. Danecki on behalf of John S. Miller, Susan D. Miller (Danecki, Robert) (Entered: 07/30/2008)
08/01/2008	<u>52</u> (2 pgs)	BNC Certificate of Mailing(RE: related document(s) <u>50</u> Order Confirming Modified Chapter 13 Plan) No. of Notices: 2. Service Date 08/01/2008. (Admin.) (Entered: 08/02/2008)
08/11/2008	<u>53</u> (1 pg)	Order on Application For Compensation Ch. 13. (emccarty,) (Entered: 08/11/2008)
08/13/2008	<u>54</u> (2 pgs)	BNC Certificate of Mailing(RE: related document(s) <u>53</u> Order on Compensation) No. of Notices: 2. Service Date 08/13/2008. (Admin.) (Entered: 08/14/2008)
08/20/2008	<u>55</u> (3 pgs; 3 docs)	Transfer of Claim Transfer Agreement 3001 (e) 2 Transferor: GE Consumer Finance (Claim No. 1) To eCAST Settlement Corporation Filed by (BECKET & LEE [IL],) (Entered: 08/20/2008)
08/22/2008	<u>56</u> (2 pgs)	BNC Certificate of Mailing(RE: related document(s) <u>55</u> Transfer of Claim) No. of Notices: 0. Service Date 08/22/2008. (Admin.) (Entered: 08/23/2008)
09/03/2008	<u>57</u> (3 pgs)	Trustee's Summary Notice of Claims Filed. (emccarty,) (Entered: 09/03/2008)
09/05/2008	<u>58</u> (3 pgs; 3 docs)	Proposed Transfer of Claim Transferor: Origen Financial, LLC (Claim No. 9) To Green Tree Servicing LLC Filed by (Taylor, Kara) (Entered: 09/05/2008)
09/10/2008	<u>59</u> (2 pgs)	BNC Certificate of Mailing(RE: related document(s) <u>58</u> Transfer of Claim) No. of Notices: 1. Service Date 09/10/2008. (Admin.) (Entered: 09/11/2008)
03/17/2009		

Exhibit 4 4	EXHIBIT 4 4 BANKRUPTCY SEARCH <u>60</u> (3 pgs)	Chapter 13 MODIFIED Plan With Notice of Opportunity to Object/Respond Filed by Robert R. Danecki on behalf of Debtor John S. Miller, Joint Debtor Susan D. Miller (Danecki, Robert) (Entered: 03/17/2009)
03/17/2009	<u>61</u> (1 pg)	Amended Schedules/Statements Filed: Schedule F, [Fee Due Yes] Filed by Robert R. Danecki on behalf of Debtor John S. Miller, Joint Debtor Susan D. Miller (Danecki, Robert) (Entered: 03/17/2009)
03/17/2009	62	RECEIPT of Amended Schedules, Statements, Petition Page or Creditors(4:08-bk-11388) [misc,amdsc] (26.00) Filing Fee. receipt number 5872481, amount \$ 26.00. (U.S. Treasury) (Entered: 03/17/2009)
03/27/2009	<u>63</u> (1 pg)	Order to Pay Trustee. (emccarty) (Entered: 03/27/2009)
04/14/2009	<u>64</u> (1 pg)	Order Confirming Modified Chapter 13 Plan. (emccarty) (Entered: 04/14/2009)
04/16/2009	<u>65</u> (2 pgs)	Additional Application for Compensation Filed by Robert R. Danecki on behalf of John S. Miller, Susan D. Miller (Danecki, Robert) (Entered: 04/16/2009)
04/16/2009	<u>66</u> (2 pgs)	BNC Certificate of Mailing(RE: related document(s) <u>64</u> Order Confirming Modified Chapter 13 Plan.) No. of Notices: 1. Service Date 04/16/2009. (Admin.) (Entered: 04/17/2009)
04/27/2009	<u>67</u> (1 pg)	Order on Application For Compensation Ch. 13. (emccarty) (Entered: 04/27/2009)
04/30/2009	<u>68</u> (2 pgs)	BNC Certificate of Mailing(RE: related document(s) <u>67</u> Order on Application For Compensation Ch. 13.) No. of Notices: 1. Service Date 04/30/2009. (Admin.) (Entered: 05/01/2009)
12/10/2009	<u>69</u> (1 pg)	Motion to Dismiss Case for Failure to Make Plan Payments Filed by Trustee (emccarty) (Entered: 12/10/2009)
01/06/2010	<u>70</u> (3 pgs; 2 docs)	Chapter 13 MODIFIED Plan With Notice of Opportunity to Object/Respond Filed by Robert R. Danecki on behalf of Debtor John S. Miller, Joint

EXHIBIT 4 4 BANKRUPTCY SEARCH		Debtor Susan D. Miller (Attachments: <u>1</u> Notice of Opportunity to Object)(Danecki, Robert) (Entered: 01/06/2010)
01/06/2010	<u>71</u> (3 pgs)	Amended Schedules/Statements Filed: Schedule I, Schedule J, [Fee Due No] Filed by Robert R. Danecki on behalf of Debtor John S. Miller, Joint Debtor Susan D. Miller (Danecki, Robert) (Entered: 01/06/2010)
01/13/2010	<u>72</u> (2 pgs)	Additional Application for Compensation Filed by Robert R. Danecki on behalf of John S. Miller, Susan D. Miller (Danecki, Robert) (Entered: 01/13/2010)
01/13/2010	<u>73</u> (1 pg)	Order Withdrawing Trustee Motion to Dismiss Upon Conditions (emccarty) (Entered: 01/13/2010)
01/19/2010	<u>74</u> (1 pg)	Order to Pay Trustee (emccarty) (Entered: 01/19/2010)
01/28/2010	<u>75</u> (1 pg)	Order on Application For Compensation Ch. 13 (emccarty) (Entered: 01/28/2010)
01/31/2010	<u>76</u> (2 pgs)	BNC Certificate of Mailing(RE: related document(s) <u>75</u> Order on Application For Compensation Ch. 13) No. of Notices: 1. Service Date 01/31/2010. (Admin.) (Entered: 01/31/2010)
02/04/2010	<u>77</u> (1 pg)	Order Confirming Modified Chapter 13 Plan (emccarty) (Entered: 02/04/2010)
02/07/2010	<u>78</u> (2 pgs)	BNC Certificate of Mailing(RE: related document(s) <u>77</u> Order Confirming Modified Chapter 13 Plan) No. of Notices: 1. Service Date 02/07/2010. (Admin.) (Entered: 02/07/2010)
02/18/2010	<u>79</u> (2 pgs)	Additional Application for Compensation Filed by Robert R. Danecki on behalf of John S. Miller, Susan D. Miller (Danecki, Robert) (Entered: 02/18/2010)
03/19/2010	<u>80</u> (1 pg)	Order on Application For Compensation Ch. 13 (emccarty) (Entered: 03/19/2010)
03/24/2010	<u>81</u> (2 pgs)	BNC Certificate of Mailing(RE: related document(s) <u>80</u> Order on Application For Compensation Ch. 13)

Exhibit 4 4

EXHIBIT 4 4 BANKRUPTCY SEARCH

		No. of Notices: 1. Service Date 03/24/2010. (Admin.) (Entered: 03/24/2010)
10/04/2010	82	Request by Toyota Motor Credit Corporation Designating Mailing Address for Notices pursuant to Bankruptcy Rule 2002(g)(1), requesting service of copies of all future notices at the address specified in the process of filing this Request. (Weisman, Gilbert) (Entered: 10/04/2010)
12/02/2010	<u>83</u> (3 pgs; 3 docs)	Transfer of Claim Transfer Agreement 3001 (e) 2 Transferor: LVNV Funding LLC its successors and assigns as (Claim No. 8) To Portfolio Recovery Associates, LLC Filed by (Garcia, Dolores) (Entered: 12/02/2010)
12/05/2010	<u>84</u> (2 pgs)	BNC Certificate of Mailing(RE: related document(s) <u>83</u> Transfer of Claim Transfer Agreement 3001 (e) 2 Transferor: LVNV Funding LLC its successors and assigns as (Claim No. 8) To Portfolio Recovery Associates, LLC Filed by) No. of Notices: 0. Service Date 12/05/2010. (Admin.) (Entered: 12/05/2010)
11/23/2011	<u>85</u> (14 pgs; 3 docs)	Transfer of Claim Transfer Agreement 3001 (e) 2 Transferor: Roundup Funding, LLC (Claim No. 10) To East Bay Funding Filed by (Montjoy, Joyce) (Entered: 11/23/2011)
11/25/2011	<u>86</u> (2 pgs)	BNC Certificate of Mailing(RE: related document(s) <u>85</u> Transfer of Claim Transfer Agreement 3001) No. of Notices: 0. Notice Date 11/25/2011. (Admin.) (Entered: 11/28/2011)
04/02/2013	<u>87</u> (1 pg)	Motion to Dismiss Case filed by Trustee (emccarty) (Entered: 04/02/2013)
04/04/2013	<u>88</u> (2 pgs; 2 docs)	Hearing Scheduled (RE: related document(s) <u>87</u> Motion to Dismiss Case filed by Trustee). Hearing scheduled for 5/8/2013 at 09:00 AM at Judge Taylor's Little Rock Courtroom. (Parrish, Marie) (Entered: 04/04/2013)
04/06/2013	<u>89</u> (3 pgs)	BNC Certificate of Mailing - Hearing(RE: related document(s) <u>88</u> Hearing Scheduled (RE: related document(s) <u>87</u> Motion to Dismiss Case filed by Trustee). Hearing scheduled for 5/8/2013 at 09:00 AM at Judge Taylor's Little Rock Courtroom.) No.

Exhibit 4 4	EXHIBIT 4 4	BANKRUPTCY SEARCH of Notices: 1. Notice Date 04/06/2013. (Admin.) (Entered: 04/06/2013)
04/09/2013	<u>90</u> (3 pgs)	Chapter 13 MODIFIED Plan With Notice of Opportunity to Object/Respond Filed by Robert R. Danecki on behalf of Debtor John S. Miller, Joint Debtor Susan D. Miller (Danecki, Robert) (Entered: 04/09/2013)
04/12/2013	<u>91</u> (2 pgs)	Financial Management Course Certificate Filed filed by Robert R. Danecki Debtor John S. Miller. (Danecki, Robert) (Entered: 04/12/2013)
04/12/2013	<u>92</u> (2 pgs)	Financial Management Course Certificate Filed filed by Robert R. Danecki Joint Debtor Susan D. Miller. (Danecki, Robert) (Entered: 04/12/2013)
04/18/2013	<u>93</u> (2 pgs)	Notice of Final Cure Mortgage Payment (emccarty) (Entered: 04/18/2013)
04/19/2013	<u>94</u> (1 pg)	Order Withdrawing Trustee Motion to Dismiss (emccarty) (Entered: 04/19/2013)
04/23/2013	<u>doc</u> (3 pgs)	Response to Notice of Final Cure Payment Rule 3002.1 (Claim # 13) with Certificate of Service Filed by Creditor Green Tree Servicing, LLC Filed by Creditor Green Tree Servicing, LLC (Mattson, Davy) (Entered: 04/23/2013)
05/01/2013	<u>95</u> (1 pg)	Order Confirming Modified Chapter 13 Plan (emccarty) (Entered: 05/01/2013)
05/02/2013	<u>96</u> (5 pgs; 2 docs)	Additional Application for Compensation Filed by Robert R. Danecki on behalf of John S. Miller, Susan D. Miller (Attachments: # <u>1</u> Creditor Matrix) (Danecki, Robert) (Entered: 05/02/2013)
05/04/2013	<u>97</u> (3 pgs)	BNC Certificate of Mailing(RE: related document(s) <u>95</u> Order Confirming Modified Chapter 13 Plan (emccarty)) No. of Notices: 1. Notice Date 05/04/2013. (Admin.) (Entered: 05/04/2013)
05/07/2013	98	Hearing Not Held. Settled or Continued Prior to the Hearing (RE: Trustee Motion to Dismiss Case - related document(s) <u>87</u>) (Previously Withdrawn; NO order due)(Albritton, Allison) (Entered: 05/07/2013)

Exhibit 4.4 05/28/2013	EXHIBIT 4.4 BANKRUPTCY SEARCH <u>99</u> (1 pg)	Order on Application For Compensation Ch. 13 (emccarty) (Entered: 05/28/2013)
06/05/2013	<u>100</u> (1 pg)	Order Authorizing Trustee Disbursement to Debtor (emccarty) (Entered: 06/05/2013)
06/06/2013	<u>101</u> (3 pgs)	Certification of Final Payment Filed by Trustee. Includes DSO Form to be Completed by Debtor(s). (emccarty) (Entered: 06/06/2013)
06/08/2013	<u>102</u> (5 pgs)	BNC Certificate of Mailing(RE: related document(s) <u>101</u> Certification of Final Payment Filed by Trustee. Includes DSO Form to be Completed by Debtor(s). (emccarty)) No. of Notices: 1. Notice Date 06/08/2013. (Admin.) (Entered: 06/08/2013)
06/10/2013	<u>103</u> (1 pg)	Certification Re: Domestic Support Obligation Filed by Robert R. Danecki on behalf of Debtor John S. Miller (Danecki, Robert) (Entered: 06/10/2013)
06/10/2013	<u>104</u> (1 pg)	Certification Re: Domestic Support Obligation Filed by Robert R. Danecki on behalf of Joint Debtor Susan D. Miller (Danecki, Robert) (Entered: 06/10/2013)
06/11/2013	<u>105</u> (3 pgs; 2 docs)	Order Discharging Both Debtors Entered on 6/11/2013(Fiallos-Flores, Jessica) (Entered: 06/11/2013)
06/13/2013	<u>106</u> (5 pgs)	BNC Certificate of Mailing - Order of Discharge(RE: related document(s) <u>105</u> Order Discharging Both Debtors Entered on 6/11/2013(Fiallos-Flores, Jessica)) No. of Notices: 13. Notice Date 06/13/2013. (Admin.) (Entered: 06/14/2013)
07/26/2013	<u>107</u> (3 pgs)	Chapter 13 Final Report and Account Filed by Trustee (emccarty) (Entered: 07/26/2013)
08/30/2013	<u>108</u> (2 pgs; 2 docs)	Order that the Chapter 13 Trustee is Discharged and Relieved of His/Her Trust in This Case. Entered on 8/30/2013(Fiallos-Flores, Jessica) (Entered: 08/30/2013)
08/30/2013	109	Bankruptcy Case Closed. The Trustee Has Performed All Duties Required and is Discharged From and Relieved of His Trust. (Fiallos-Flores, Jessica) (Entered: 08/30/2013)

EXHIBIT 4 4 BANKRUPTCY SEARCH

PACER Service Center			
Transaction Receipt			
07/21/2017 13:58:01			
PACER Login:	mc0019:2593428:0	Client Code:	
Description:	Docket Report	Search Criteria:	4:08-bk-11388 Fil or Ent: filed From: 1/1/1980 To: 7/21/2017 Doc From: 0 Doc To: 99999999 Term: included Format: html Page counts for documents: included
Billable Pages:	7	Cost:	0.70



Search Results

LEAH ROVNAGHI
Friday Eldredge & Clark
400 West Capitol Avenue
Suite 2000
Little Rock, AR 72201

Date: 07/21/2017
Order #: 59842764
Customer #: 504120
Reference 1: USBC / AR
Reference 2: --

Target Name: Williams, Susan D

Jurisdiction: U.S. Bankruptcy Court, Arkansas Western District

Search Type: Bankruptcy - Searched as Petitioner
Results: No Records Found

Searched Through: 07/14/2017
Office: Western District

BRIAN H. LEFEVRE
Chicago Team 1
208 S. LaSalle Street
Suite 814
Chicago, IL 60604
(888) 829-5817 Ext.3582
Brian.LeFevre@wolterskluwer.com

This report contains information compiled from sources which CT Lien Solutions considers reliable but does not control. The information provided is not a certified record of the applicable jurisdiction unless otherwise indicated. CT Lien Solutions does not (i) warrant or guarantee the accuracy, completion or timeliness of the information provided or (ii) accept any liability for delays, errors or omissions in the information provided. CT Lien Solutions is not an insurer with regard to this information or these services. Under no circumstances shall CT Lien Solutions be liable for any loss of underlying collateral or loss (or decreased priority) of security interest in connection with this information or these services. Any categorization of search results is provided for convenience only and is not to be construed as a legal opinion concerning the status of filings.



Search Results

LEAH ROVNAGHI
Friday Eldredge & Clark
400 West Capitol Avenue
Suite 2000
Little Rock, AR 72201

Date: 07/21/2017
Order #: 59842764
Customer #: 504120
Reference 1: USBC / AR
Reference 2: --

Target Name: Lafrance, Wendy

Jurisdiction: U.S. Bankruptcy Court, Arkansas Eastern District

Search Type: Bankruptcy - Searched as Petitioner

Results: No Records Found

Searched Through: 07/14/2017

Searched: 10 Years

Office: Eastern District

BRIAN H. LEFEVRE
Chicago Team 1
208 S. LaSalle Street
Suite 814
Chicago, IL 60604
(888) 829-5817 Ext.3582
Brian.LeFevre@wolterskluwer.com

This report contains information compiled from sources which CT Lien Solutions considers reliable but does not control. The information provided is not a certified record of the applicable jurisdiction unless otherwise indicated. CT Lien Solutions does not (i) warrant or guarantee the accuracy, completion or timeliness of the information provided or (ii) accept any liability for delays, errors or omissions in the information provided. CT Lien Solutions is not an insurer with regard to this information or these services. Under no circumstances shall CT Lien Solutions be liable for any loss of underlying collateral or loss (or decreased priority) of security interest in connection with this information or these services. Any categorization of search results is provided for convenience only and is not to be construed as a legal opinion concerning the status of filings.



Search Results

LEAH ROVNAGHI
Friday Eldredge & Clark
400 West Capitol Avenue
Suite 2000
Little Rock, AR 72201

Date: 07/21/2017
Order #: 59842764
Customer #: 504120
Reference 1: USBC / AR
Reference 2: --

Target Name: Lafrance, Wendy

Jurisdiction: U.S. Bankruptcy Court, Arkansas Western District

Search Type: Bankruptcy - Searched as Petitioner
Results: No Records Found

Searched Through: 07/14/2017
Searched: 10 Years
Office: Western District

BRIAN H. LEFEVRE
Chicago Team 1
208 S. LaSalle Street
Suite 814
Chicago, IL 60604
(888) 829-5817 Ext.3582
Brian.Lefevre@wolterskluwer.com

This report contains information compiled from sources which CT Lien Solutions considers reliable but does not control. The information provided is not a certified record of the applicable jurisdiction unless otherwise indicated. CT Lien Solutions does not (i) warrant or guarantee the accuracy, completion or timeliness of the information provided or (ii) accept any liability for delays, errors or omissions in the information provided. CT Lien Solutions is not an insurer with regard to this information or these services. Under no circumstances shall CT Lien Solutions be liable for any loss of underlying collateral or loss (or decreased priority) of security interest in connection with this information or these services. Any categorization of search results is provided for convenience only and is not to be construed as a legal opinion concerning the status of filings.

EXHIBIT 6.1 PROPERTY DESCRIPTION
EXHIBIT 6.1 NATURAL STATE CULTIVATION PROPERTY DESCRIPTION

Tract 1 Description:

As surveyed: A part of the southwest quarter of section 23, Township 4 South, range 11 west, Jefferson county, Arkansas, being more particularly described as follows: beginning at the northeast corner of said southwest quarter; thence s 00° 26' 56" w a distance of 1327.44 feet to a point; thence s 00°26'56" w a distance of 1327.44 feet to a point on the south line of said section 23; thence n 88°51'13"w along said south line of section 23 a distance of 422.64 feet to a point; thence n01°08'47"e a distance of 473.24 feet; thence n36°01'20"w a distance of 677.74 feet to a point; thence s51°58'40"w a distance of 623.67 feet to a point on the east right of way line of interstate 530; thence along said east right of way line n 45°07'56" w a distance of 256.69 feet to a row monument; thence continuing along said right of way line n 37°25'10"w a distance of 277.41 feet to a row monument; thence continuing along said right of way line n 13°33'49" w a distance of 250.78 feet to a point; thence continuing along said right of way line n 11°22'38" w a distance of 800.00 feet to a point; thence continuing along said right of way line n 11°27'38" w a distance of 664.59 feet to a point; thence leaving said right of way line s 88°23'27"e a distance of 722.92 feet to a rebar; thence s 88°23'27" e a distance of 1319.72 feet to the point of beginning; containing 87.28 acres, more or less.

Subject to 15-ft utility easement described as follows: commence at the northeast corner of said southwest quarter; thence s 00° 26' 56" w a distance of 1327.44 feet to a point; thence s 00°26'56" w a distance of 1327.44 feet to a point on the south line of said section 23; thence n 88°51'13"w along said south line of section 23 a distance of 422.64 feet to a point; thence n01°08'47"e a distance of 473.24 feet; thence n36°01'20"w a distance of 677.74 feet to a point; thence s51°58'40"w a distance of 623.67 feet to the point of beginning being on the east right of way line of interstate 530; thence along said right of way line n45°07'56"w a distance of 256.69 feet to a point; thence continuing along said right of way line n37°25'10"w a distance of 277.41 feet to a point; thence continuing along said right of way line n13°33'49" a distance of 250.78 feet to a point; thence continuing along said right of way line n11°22'38"w a distance of 13.09 feet; thence leaving said right of way n78°37'22"e a distance of 15.00 feet to a point; thence s11°22'38"e a distance of 14.71 feet to a point; thence s13°34'50"e a distance of 245.42 feet to a point; thence s37°25'10"e a distance of 273.23 feet to a point; thence s45°07'56"e a distance of 257.55 feet to a point; thence s51°58'40"w a distance of 15.12 feet to the point of beginning; containing 11,908 square feet (0.273 acres), more or less.

Tract 2 Description:

As surveyed: a part of the southwest quarter of section 23, township 4 south, range 11 west, jefferson county, arkansas, being more particularly described as follows: Commencing at the northeast corner of said southwest quarter; thence s 00° 26' 56" w a distance of 1327.44 feet to a point; thence s 00°26'56" w a distance of 1327.44 feet to a point on the south line of said section 23; thence n 88°51'13"w along said south line of section 23 a distance of 422.64 feet to the point of beginning; thence s88°51'13"e a distance of 371.38 feet to a point on the east right of way line of interstate 530; thence along said right of way line n00°17'15"w a distance of 16.55 feet to found angle iron; thence continuing along said right of way line n64°52'25"w a distance of 181.11 feet to a point; thence continuing along said right of way line n18°32'00"w a distance of

EXHIBIT 6.1 PROPERTY DESCRIPTION

252.86 feet to a point; thence continuing along said right of way line n45°07'56"w a distance of 256.69 feet to a point; thence leaving said right of way line n51°58'40"e a distance of 623.67 feet to a rebar and cap; thence s38°01'20"e a distance of 677.74 feet to a rebar and cap; thence s01°08'47"w a distance of 473.24 feet to the point of beginning, being a rebar and cap; containing 12.42 acres, more or less.

	Female	Minority	% Ownership
Joe Courtright			15.73%
Stephen LaFrance			5.66%
Wendy LaFrance	y		10.07%
Dr. Scott Schlesinger			5.66%
Dr. Kelli Schlesinger	y		10.07%
Dr. Cliff Peck			4.23%
Deane Peck	y		7.51%
Robert DeBin			4.46%
Keith Mooney			4.23%
Donna Mooney	y		7.51%
Alonzo Williams		y	8.45%
Susan Williams	y	y	15.02%
Donna Terrell	y	y	1.41%

Totals

Female	52%
Minority (old definition)	25%
Minority Ownership (Current Definition which included females)	60%

EXHIBIT 4.1 OWNERS CREDIT SCORES

Natural State Medicinals
Arkansas Licensing Application
Exhibit 4.1

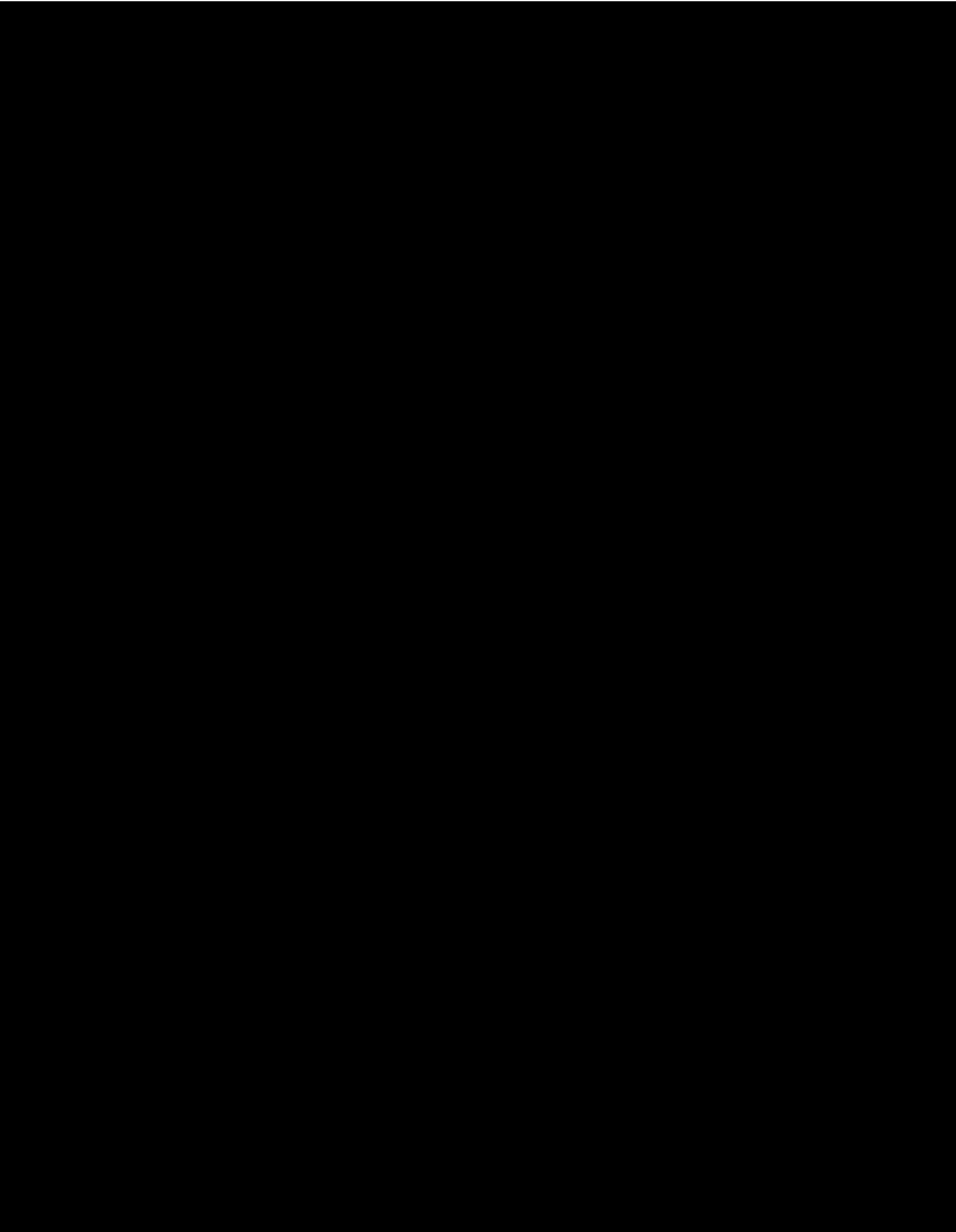



Personal & Confidential

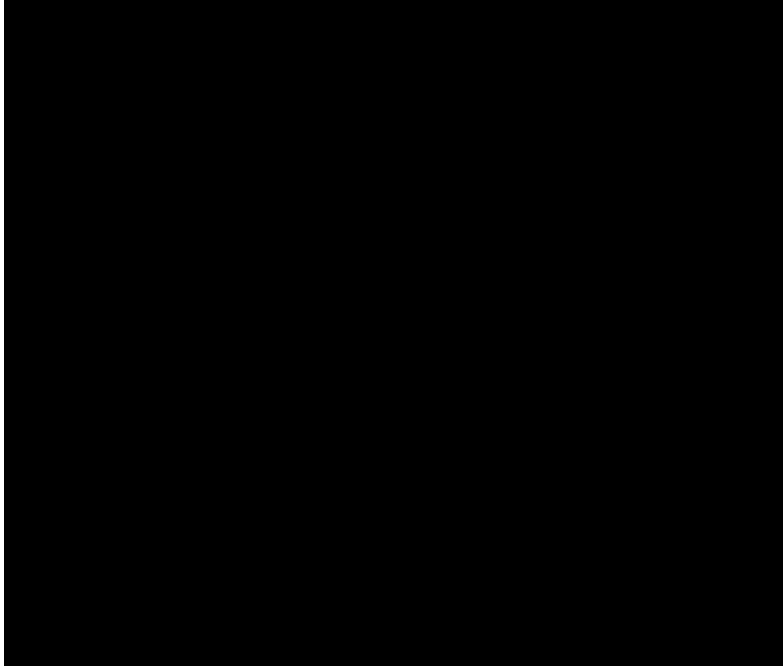

Personal & Confidential

EXHIBIT 4.1 CREDIT HISTORIES



Personal & Confidential

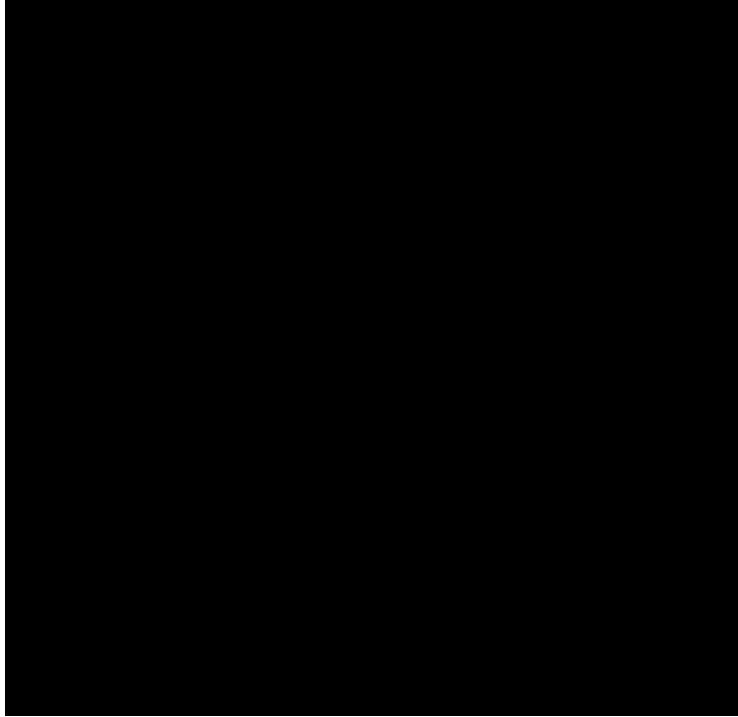

Personal & Confidential



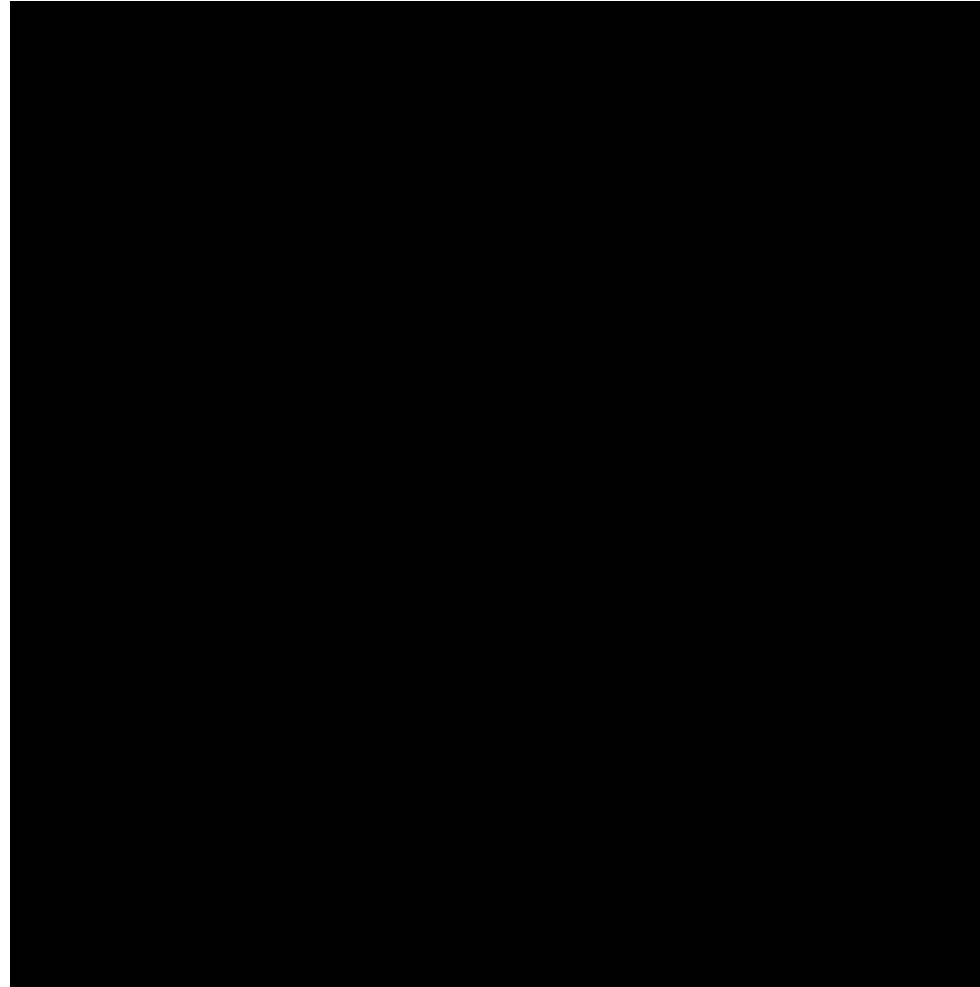

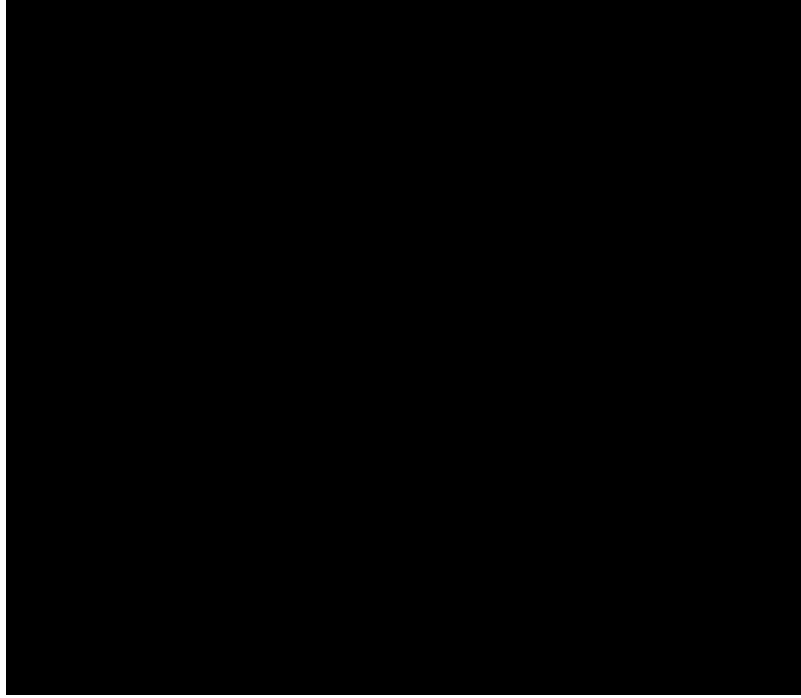

Personal & Confidential

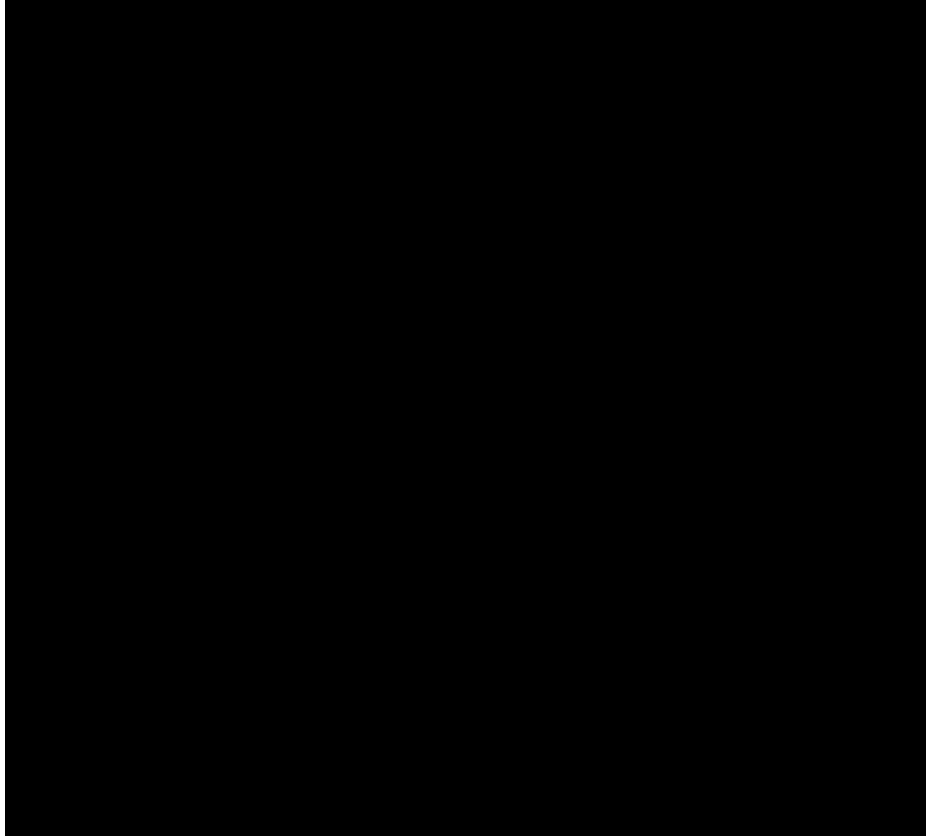

Personal & Confidential



Print This Page

Close Window

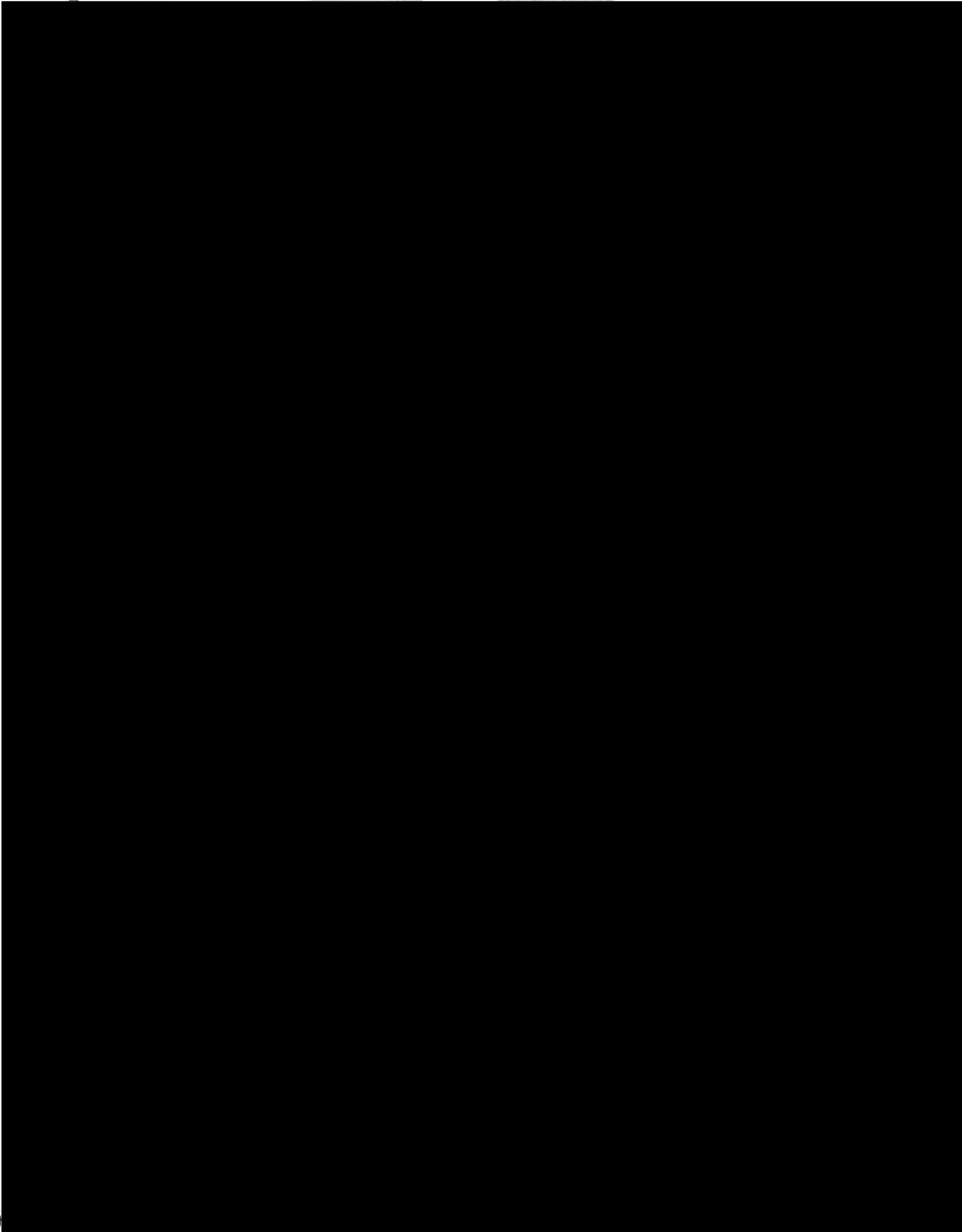

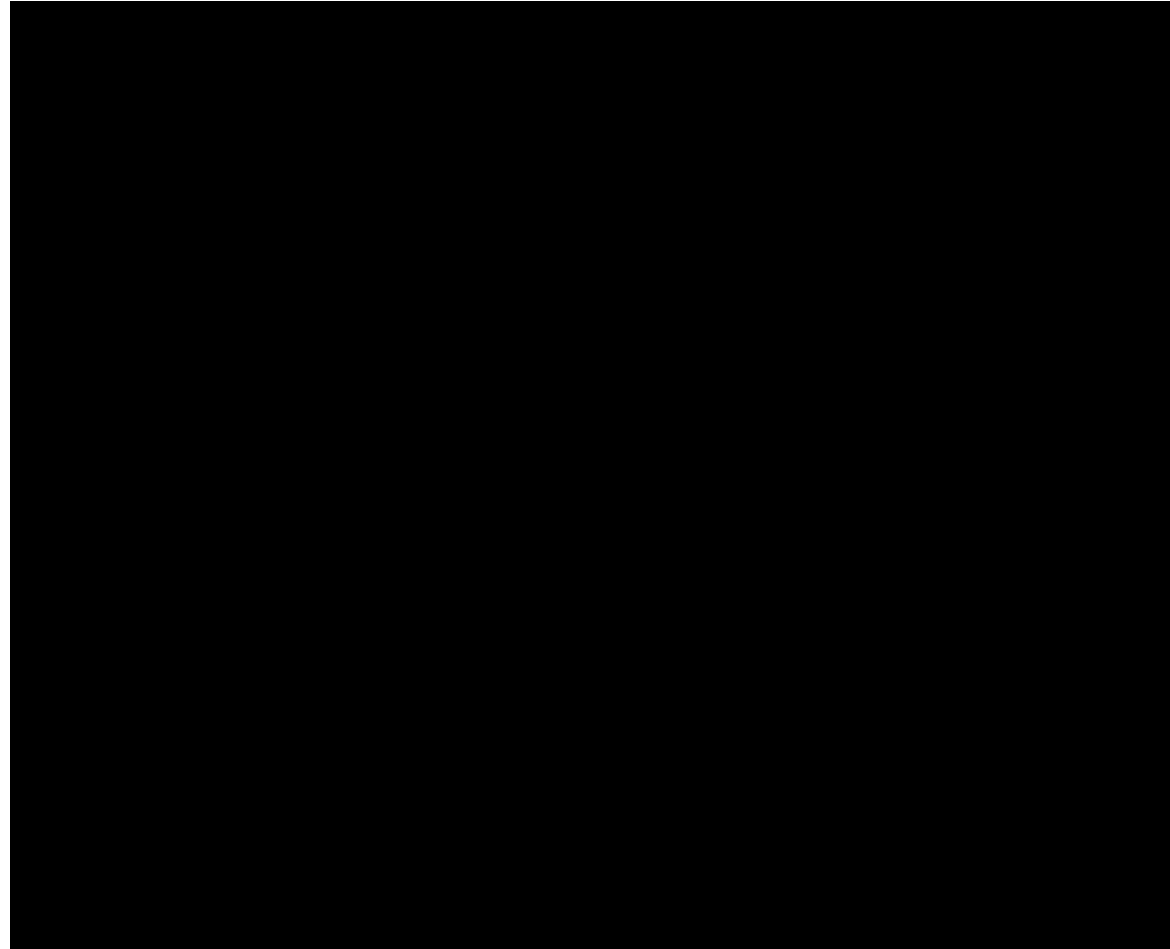

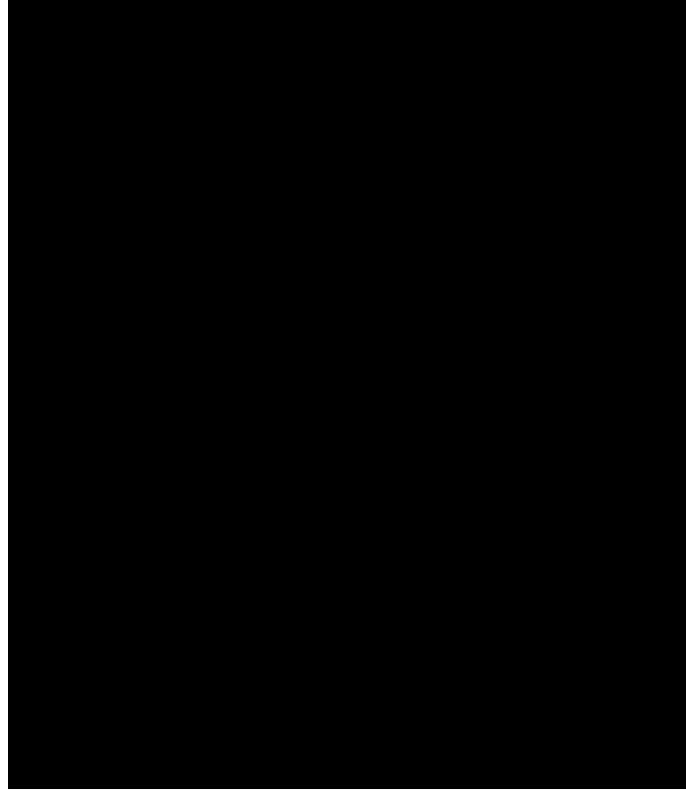

Personal & Confidential

9/10/2017

Natural Sate Medicinals Cultivation
State of Arkansas Cultivation Application
Exhibit 4.1

Equifax Personal Solutions: Credit Reports, Credit Scores, Protection Against Identity Theft and more
Equifax Response
EXHIBIT 4.1 CREDIT HISTORIES
Referenced Form Section E
Schedule 4



▶ Print This Page

▶ Close Window

