

15 July 2020



Phil Pennington

By Email: Phil.Pennington@rnz.co.nz

Dear Phil

INFORMATION REQUEST – Harington Street Carpark

We write in response to your email dated 11 June 2020 in which you requested the below information. We note that the due date for this request was extended to 15 July 2020.

- 1. All the expert reports received by council into why this project went wrong, with all attachments**
- 2. And all reports received by council about how to remedy this, with all attachments.**
- 3. full links to all info in council meetings and reports that is publicly available (but may required navigating of your website, and noting TCC will know far better than RNZ does, where this resides).**
- 4. What is being done to remedy this project in terms of:**
 - a. The physical structure – will it be demolished?**
 - i. At whose cost?**
 - b. The financial exposure – will/is council seeking redress?**
 - i. Who from? Harrison Grierson?**
 - ii. What consideration has been given to legal action?**
 - iii. What is happening re legal action?**
 - c. The danger of this being repeated**
 - i. Has/will council complaint to ENZ about the structural engineer?**
 - ii. Are there any other projects council is or had used this engineer on?**
 - iii. Will those be reviewed?**

We have considered your request in accordance with the Local Government Official Information and Meetings Act 1987 (“**LGOIMA**”) and respond as follows.

1. Please find the requested reports enclosed with this letter.

Please note that some reports have been removed or redacted (partially blacked out) in accordance with the following sections of LGOIMA:

1. Section 7(2)(g), to “*maintain legal professional privilege*”.
2. Section 7(2)(i), to “*enable any local authority holding the information to carry on, without prejudice or disadvantage, negotiations (including commercial and industrial negotiations)*”.

We have considered the public interest and appreciate that there is a desire for transparency around the issues with the project, as well as the steps being taken by Council to address those issues.

However, we consider that there is a genuine need to withhold these reports for the time being, so that Council can act effectively on behalf of the public. The premature release of this information could undermine Council’s position in any potential civil negotiations and would therefore hinder its ability to minimise costs to the public.

2. Same as above.
3. There are no publicly available Council meetings or reports in relation to problems with, or remediation of, this project. Some reports that were excluded from the public are enclosed with this letter in response to questions 1 and 2.
4. Regarding the remediation of this project:
 - a. The Council has not yet decided the future of the structure. Unfortunately, demolition is likely to be an option that the council will need to consider.
 - i. The Council, as building owner, would fund the demolition, but would seek to recover the wasted costs involved from those who are responsible for the failed project.
 - b. Regarding Council's seeking of redress for financial exposure:
 - i. Yes, as well as others involved in the failed project.
 - ii. The Council has taken advice and has now commenced a recovery process.
 - iii. The Council does not want to prejudice the recovery action for the ratepayers of Tauranga and, given that process has now commenced, it would be inappropriate to comment.
 - c. Regarding danger of this being repeated:
 - i. Yes, a complaint has been made to ENZ.
 - ii. From an initial review of our records we can confirm one of the engineers involved in the Harington Street Transport Hub Project issued a Producer Statement – PS1 – Design to the council in respect of the structural design of a small retaining wall.
 - iii. We are arranging for a Chartered Professional Engineer with the appropriate experience and capability to peer review this design.

You have the right to seek an investigation and review by the Ombudsman of this decision. Information about how to make a complaint is available at www.ombudsman.parliament.nz or freephone 0800 802 602.

We may be publishing our responses on our website as your request may be of interest to others. All personal information will be removed and only the question and answers will be seen.

If you wish to discuss this decision with us, please feel free to contact the writer.

Yours sincerely



Coral Hair
Manager
Democracy Services

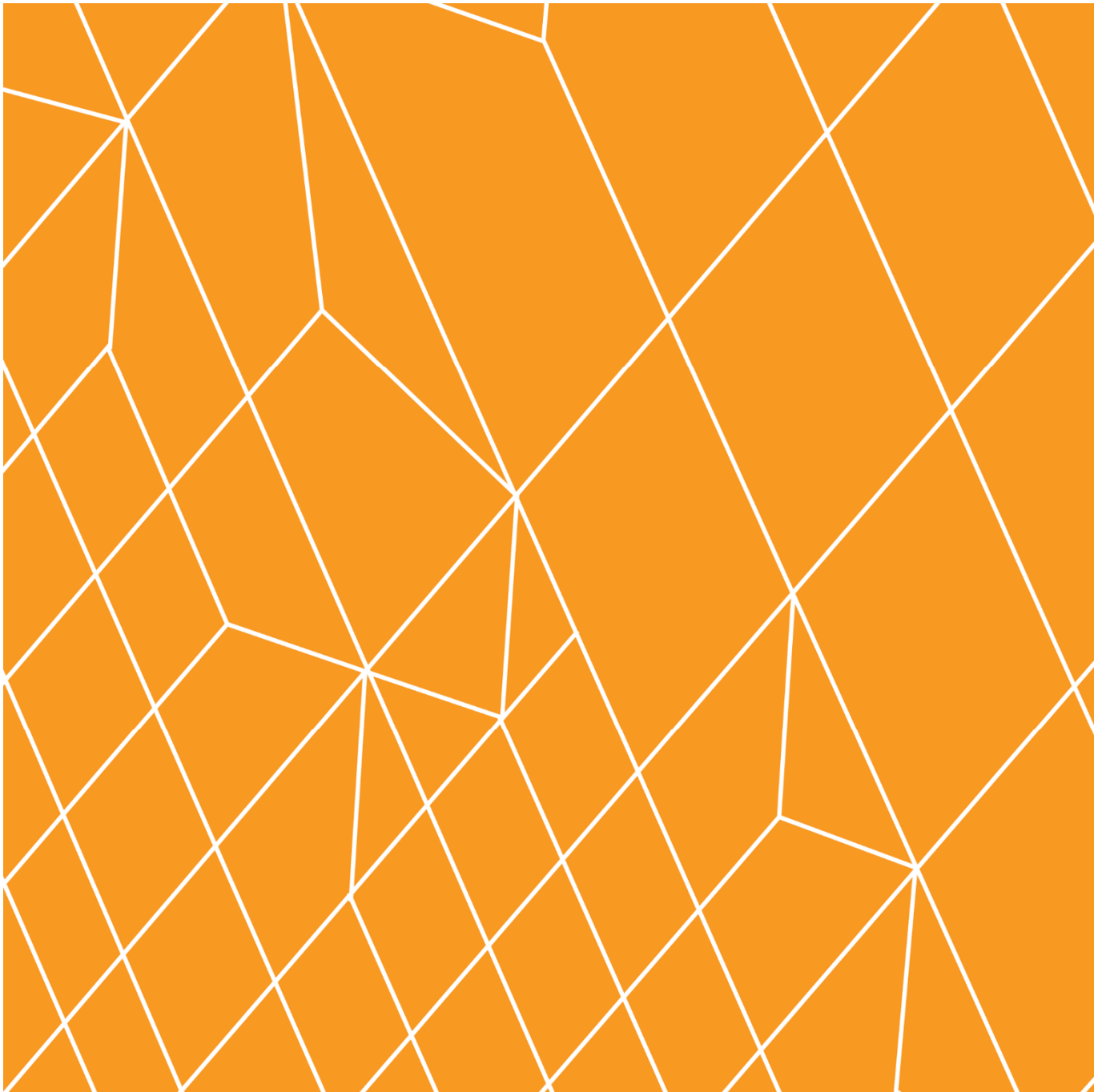

TCC - Transport Hub

16 Harington Street
Tauranga

Report

Report

TCC - Transport Hub, 16 Harington Street

Prepared For:
Steve Wiggill, Tauranga City Council

Date: 17 July 2019
Project No: 138991.00
Revision No: 1

Prepared By:



Eva Cuttriss
PROJECT DIRECTOR
Holmes Consulting LP

Reviewed By:



Bruce Galloway
TECHNICAL DIRECTOR

Report Issue Register

DATE	REV. NO.	REASON FOR ISSUE
17/07/2019	1	High Level Structural Review

CONTENTS

1 Executive Summary1

2 Introduction1

3 Scope of Work1

4 Limitations1

5 Description of the development1

6 Observations 3

6.1 Ramp Movement joints 3

6.2 Braced bays 5

6.3 Foundations..... 6

6.4 Vehicle barriers 7

6.5 Stairs 8

6.6 Durability..... 8

6.6.1 Reinforced concrete 8

6.6.2 Structural steel 9

7 Recommendations 9

1 EXECUTIVE SUMMARY

2 INTRODUCTION

Holmes Consulting LP have been engaged by Tauranga City Council to complete a brief high-level structural review of the Harington Street Transport Hub, Tauranga. This review includes current construction drawings, specification and design report.

3 SCOPE OF WORK

The scope of work for this project included the following:

1. Carry out a brief high-level review of the structural drawings, design report and specification.
2. Provide a summary of any obvious non-compliances with clauses B1 or B2 of the Building Code (as relates to structure).
3. List any initial questions that arise which could be put to the designer for their comment.
4. On the basis of the above, provide an opinion as to whether a detailed peer review should be commissioned.
5. Report on our findings and recommendations.

Our review has been primarily of a qualitative nature, and calculations have not generally been carried out unless specifically referenced. We have also not had the opportunity to discuss our queries with the original designer as part of this initial review.

Our understanding of the site progress at the time of review is that construction is underway on site with foundations, basement retaining walls and suspended levels up to approximately L03 constructed. Structural steelwork has been erected to approximately L05 with braced bays to L07.

Holmes Consulting LP would also like to note that this review is based on the documentation presented to us at the time of the review and appreciate that the Structural Engineer, in the course of normal construction monitoring work, may have developed some details further.

4 LIMITATIONS

Findings presented as a part of this project are for the sole use of Tauranga City Council in its evaluation of the subject property. The findings are not intended for use by other parties, and may not contain sufficient information for the purposes of other parties or other uses.

Our review has been restricted to structural aspects only. Our professional services are performed using a degree of care and skill normally exercised, under similar circumstances, by reputable consultants practicing in this field at this time. No other warranty, expressed or implied, is made as to the professional advice presented in this report.

5 DESCRIPTION OF THE DEVELOPMENT

The new Harington Street Transport Hub is understood to be a 9-storey structural steel framed building with 2 basement levels and 7 levels above ground. Foundations are formed as shallow, 600mm wide x 700mm deep strip footings with a 350mm insitu concrete basement slab and concrete perimeter walls.

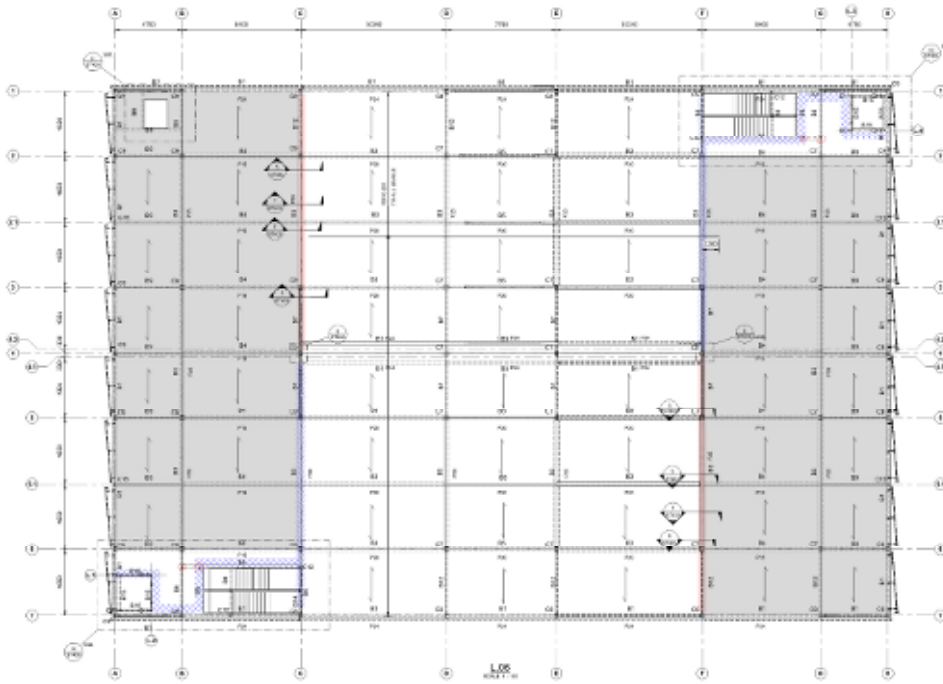

Figure 1 - Level L06 floor plan

Proprietary steel tray-deck “Comflor 80” provides permanent formwork and strength for insitu concrete floors, including ramps to all levels. Steel framing provides gravity support to all floors and steel cross-braced bays of approximately 4.7m long provide lateral load resistance above the basement concrete retention walls.

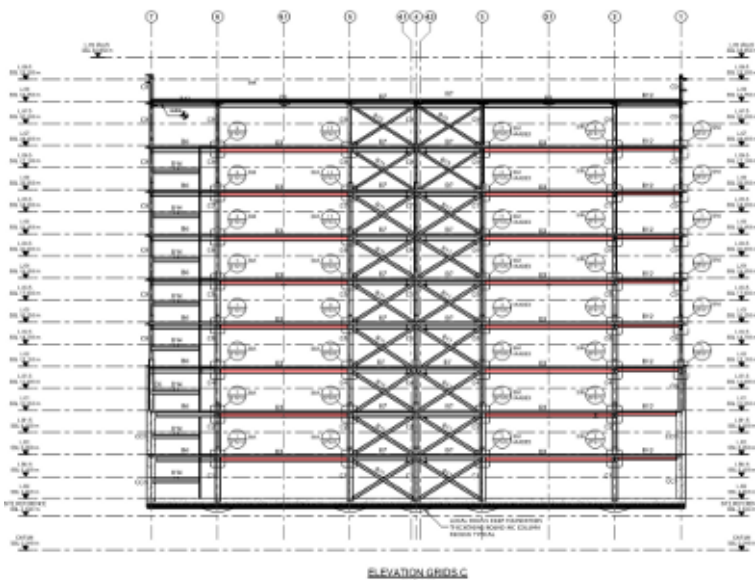

Figure 2 - Cross section showing braced bay and floor levels

The braced bays utilise a brace connection (INERD connection) which is intended to yield during an Ultimate Limit State (ULS) event in a ductile manner and dissipate energy. The INERD connection is not covered by the standards referenced by the New Zealand Building Code and would therefore be considered an alternative solution. The INERD connection is detailed using a steel 'pin' which is subjected to flexural actions by the braces. The pin sizes vary for each braced bay and level, presumably to match the design forces obtained from the original analysis.

The site is underlain with Matua Subgroup silty sands and classified as a Class D or deep/soft soil site in accordance with NZS1170.5. The geotechnical investigation report states that, in the absence of ground improvement works extending a depth equal to the minimum plan dimension of the footing, a Geotechnical ultimate bearing pressure for a 1.0m wide strip footing, 1.0m deep is 220kPa. A conventional strength reduction factor ($\phi=0.5$) is required to be applied to this value. The geotechnical report also states that the site was found to have no liquefaction response under an SLS event and only negligible amounts of liquefaction under a ULS event.

A hydrostatic uplift force on the basement slab is proposed of up to 15kPa on the basis of a 1.0m sea level rise. This is outlined to have been requested as a consideration by the "project principles".

6 OBSERVATIONS

Our review of Harington Street Transport Hub is qualitative and performed as a brief and high-level review only. The review is intended to provide Tauranga City Council with a summary of any obvious non-compliances with clauses B1 or B2 of the Building Code (as relates structure).

6.1 Ramp Movement joints

A recent revision of the structural drawings has introduced 100mm wide movement joints to the top of each ramp.

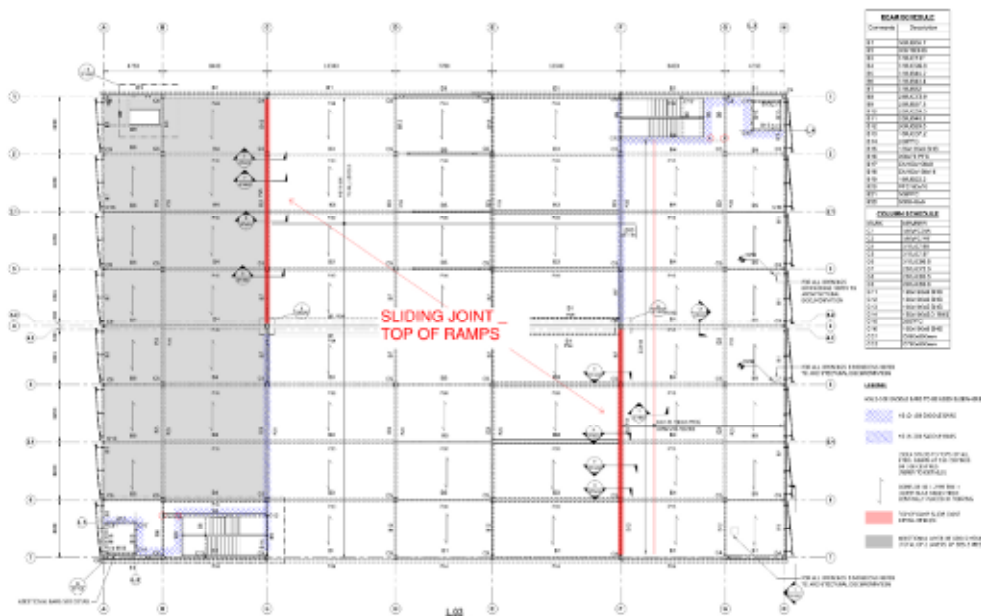

Figure 3 - Floor plan showing sliding joints top of ramps

On the basis of the information available we are unable to understand the insertions of joints in ramps, given that gaps appear to be proposed in the concrete floors but not in the adjacent connected steel

beams (which have instead been strengthened). Depending on what solution was intended by the designers, the following is a high-level summary of the key concerns identified:

1. If movement joints (as currently proposed) were intended at either end of the ramps to effectively split the building into two separate structures:
 - The movement joints proposed do not accommodate the total building displacement. The DFR states that the expected displacements of the original building are 186mm and 250mm in the longitudinal and transverse directions respectively. This would imply a seismic gap in the order of 375mm to 500mm would be required at the ends of the ramps and along the central grid to achieve full separation and prevent pounding.
 - The steel edge beams and central internal columns connecting split levels are not currently proposed to be separated from the separated portions of the building. This means that the seismic joints detailed would not achieve separation of the ramp levels.
2. If no gap was introduced (as we understand was the intent of the original design):
 - The ramps effectively join the adjacent floors together and therefore contribute to the overall lateral load resistance. The ramps would therefore need to be designed to transfer the lateral loads from roof to foundation, including transferring these struts around the corners between ramps.
 - Given that the ramps are not capable of developing a ductile mechanism, this also implies the overall energy dissipation assumed ($\mu=4$) is likely inappropriate for such a mixed system (ramps are unable to accommodate inelastic displacement and should be designed as elastic rather than fully ductile).
 - The forces induced through the ramps would also likely lead to a significant torsion being developed which would need to be resisted by elastically responding lateral load resisting elements to balance these torsional forces.
3. If the intent of the added joints was to provide separation between individual floors only:
 - A single joint would be expected per floor (rather than the two joints currently proposed). These joints are typically provided mid-ramp due to complexities of separation of adjacent structure if the joints are provided at existing floor levels.
 - As noted above, it is implicit in this approach that the joint must be through the full ramp section (including both concrete slab and supporting steel beams).
 - Adjacent structure to the ramp must also be compatible with the deformations imposed between the relevant floors - central columns would need to be assessed to accommodate the relative drifts between adjacent ramps.

We suggest clarifying the intended design intent with the original designer, as it is difficult to draw consistent conclusions from the information that has been provided to us.

The details currently provided to support the introduction of sliding details to the top of ramps do not appear to be adequately detailed to support gravity loads or manage deterioration from constant vehicle movement across these joints:

- The slotted cleats proposed per the figure below comprise long, slender plates with no stiffening to prevent plate buckling.
- The long slots proposed mean the narrow portion of plate remaining between the slots is unlikely to be insufficient to cantilever from the supporting beam to support the vertical loads applied by the bolts.

- The slotted holes proposed mean that the bolt group cannot resist the applied moment, and therefore torsional loads must be applied to the supporting beam which will likely be unable to resist these.

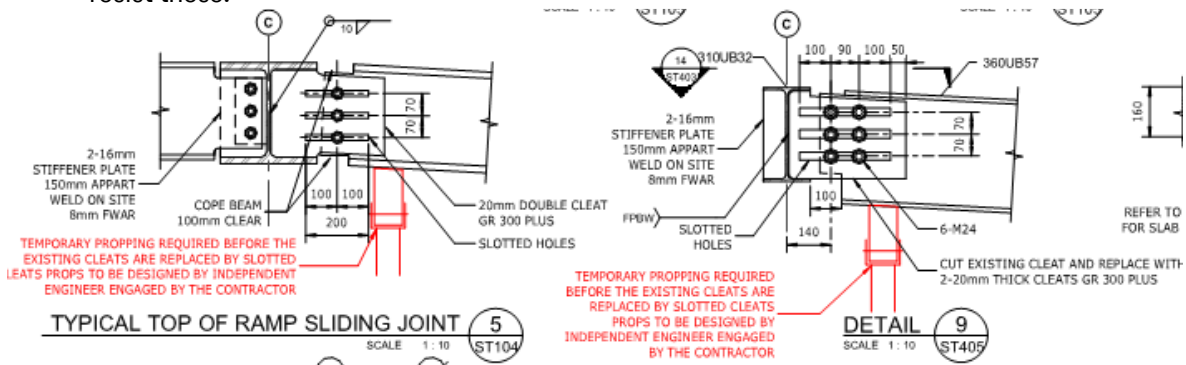

Figure 4 - Slotted beam connections to top of ramp

We suggest the designer is asked to review these slotted connections and comment on the intended means of transferring gravity loads to the supporting beams.

6.2 Braced bays

Based on concerns about the potential for load sharing between braced bays and ramps in the original analysis, we have undertaken a basic hand calculation of the brace forces at level L01 (above basement walls).

Key assumptions with respect to seismic demands used to assess capacity include:

- Period has been taken as 1.2 seconds from the DFR.
- Hand calculations were carried out to determine the seismic coefficient at the stated $\mu=4$, and to generate a base shear and equivalent static load distribution based on the floor masses assumed to be acting above level L01 (top of basement level).
- No allowance has been made for torsional response or mass eccentricity – this would typically be expected to increase demands for a regular structure such as this one by approximately 20%.
- It is assumed that the larger dimension of the rectangular INERD pins is in the primary force direction (the orientation of the pins is not specified in the drawings).
- In assessing the foundation design, the overstrength factor of the braced frames was assumed as only $\phi_o=1.25$ (i.e. assumes the braces have been tuned perfectly up the height of the building so that the overstrength is absolutely minimised).

A summary of the questions raised about the steel braced frames are as follows:

- The INERD brace connection system isn't covered by NZS3404, so would be considered an alternative solution under the NZBC which would require a special study to be carried out to confirm compliance. We haven't reviewed the structural calculations and are therefore unable to comment on whether the level of investigation carried out is likely to meet the requirements for a special study.
- The expected inter-storey drift of 1.69% reported in the DFR exerts significant demands on the yielding pins (equating to out of plane deformations equivalent to the depth of the pin, occurring over a length of only 3 x pin depth). Given our previous experience with low cycle fatigue, these types of deformations are often unsustainable, and we would expect that such a low cycle fatigue

study should have been carried out as part of the special study for the original braced frame design.

- On the basis of the basic hand calculations described above, the force expected in the L01 brace shows the flexural capacity of the yielding pin at the ends of the braces to be between 30% and 90% of that required for $\mu=4.0$ loads. However, the actual capacity is expected to be lower still, as the basic 2D hand calc takes no account of torsional response.

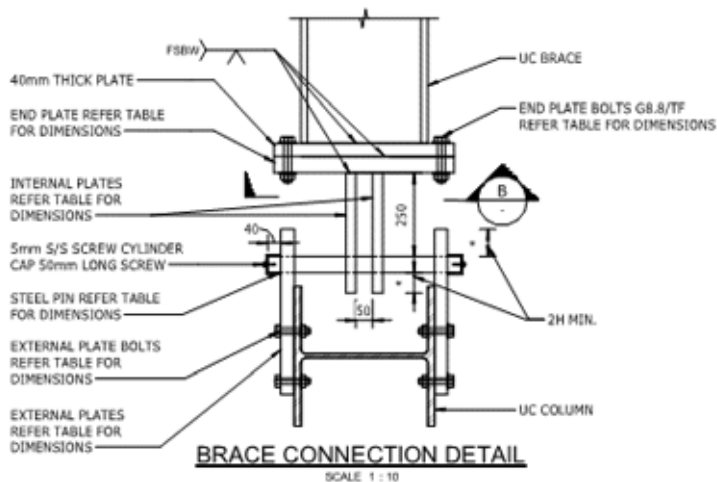

Figure 5 - Brace connection detail from ST407

- There is a concern with the development of a soft-storey mechanism on any level. As with Buckling Restrained Braces (BRBs), which follow a similar concept to these INERD braces, there is a need for some of the lateral force resistance to come from frames or significant elastic columns – these stiffening elements, in effect, protect against a soft-storey forming, and all the while, the braces are providing the majority of the lateral resistance and energy dissipation.
- According to the DFR, the two-way braced frame has been designed for full ductility. For Category 1 (fully ductile) systems, NZS3404 requires secondary elements (such as columns/collector beams) to meet the material requirements of Section 12. However, there is no reference in the Specification or Drawings to the steel grades specified, other than reference to grade 300/350. The only material reference is the specification of ‘High Ductile’ steel for the pins on drawing ST407. We note that all of these secondary elements should have been specified using grade S0 steel in accordance with NZS3404.
- The steel braces are typically connected via the INERD pin connection to the outside of the column flanges. However, the drag beams are typically connected to the middle of the column web via a simple web cleat connection. As such, there is no obvious mechanism to transfer the beam drag forces from the centre of the column web into the column flanges to be able to get these forces into the bracing system. The recent drag beam strengthening details that have been added to the drawing set also do not appear to address this load path issue.

6.3 Foundations

Basic hand calculations were carried out to assess the likely capacity of the shallow strip foundation system to resist the applied loads.

Geotechnical foundation design parameters were taken from the geotechnical report attached to the DFR – in particular, the geotechnical ultimate bearing capacity for a 1m wide strip foundation was given as 220kPa. For assessment of ULS actions, this equates to a bearing capacity of 110kPa.

The following is a summary of our preliminary findings with regards to the foundation demands:

- **Braced Frame Foundations:** Based on the same hand calcs for seismic actions on the braced frames, the overturning actions of the braced frames on grids C and F cause compression reactions on the foundations that significantly exceed the allowable ULS bearing capacity (noting that the basic hand calcs do not consider the additional loads imposed by torsion or mass eccentricities). The tension forces under these braced frames also exceed the weight of the structure that is available to hold them down. In summary, the foundations do not appear to have sufficient capacity to support the seismic overturning actions on the internal braced bays (no assessment has been made of external braced bays, as this would require a more detailed assessment of the overall loads on the basement foundation walls).
- **Gravity Column Foundations:** Basic hand calculations were carried out on the column at grid C3 to assess the likely foundation capacity to support gravity loads. The bearing stress under factored gravity loads is estimated to be somewhere between 350kPa and 1100kPa (depending on how much of the slab and foundation beam can be engaged). Again, this is significantly in excess of the 110kPa allowable ULS bearing capacity specified in the geotechnical report, indicating that the building may have settlement issues under self-weight.

6.4 Vehicle barriers

Vehicle barriers are arranged to the perimeter of all suspended floors. At the ends of ramps, a 240kN barrier is proposed (Grid A and H) on ST400. The barrier is a proprietary system which is installed to the completed slab edge. The Comflor slab and beam under are insufficient to provide overturning resistance to this barrier in the figure below. Neither beam nor slab appears to be detailed to provide resistance to a 240kN barrier load.

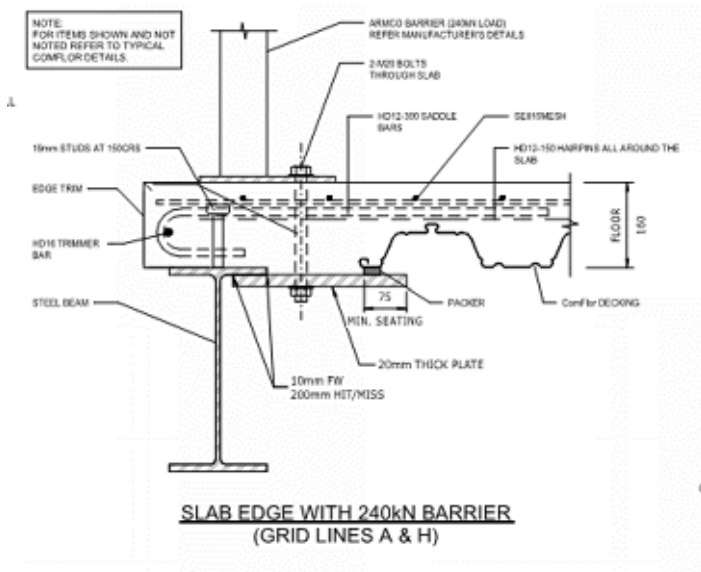

Figure 6 - 240kN vehicle barrier support structure on ST400

The drawings show two layers of SE815 mesh to some areas of the floor slab. When considered in conjunction with the need to lap mesh in both directions, this would result in reinforcing covers significantly less than required by NZS3101. Alternative reinforcing options to increase covers have been proposed by the designer as a notice to the contractor (NTC300) and included in this review. The most effective of which uses HD10 each way in place of mesh or HD10 bars to lap mesh in both directions. With this proposed alternative and using careful placement of reinforcing, minimum cover of 35mm can be achieved to meet NZS3101 for B1 exposure classification.

6.6.2 Structural steel

The design report indicates that a C5-M corrosion protection system is to be adopted for this structure in accordance with NZS3404:1997.

Where steel is proposed to be site welded, it is important that enclosed surfaces can be sealed to avoid moisture ingress to untreated steelwork. Where remedial connections are proposed to installed steelwork there are several instances where it does not appear possible to seal concealed steelwork interfaces. See figure 8 below showing lengths of weld that are inaccessible on site and where moisture ingress may occur in such a site-welded joint.

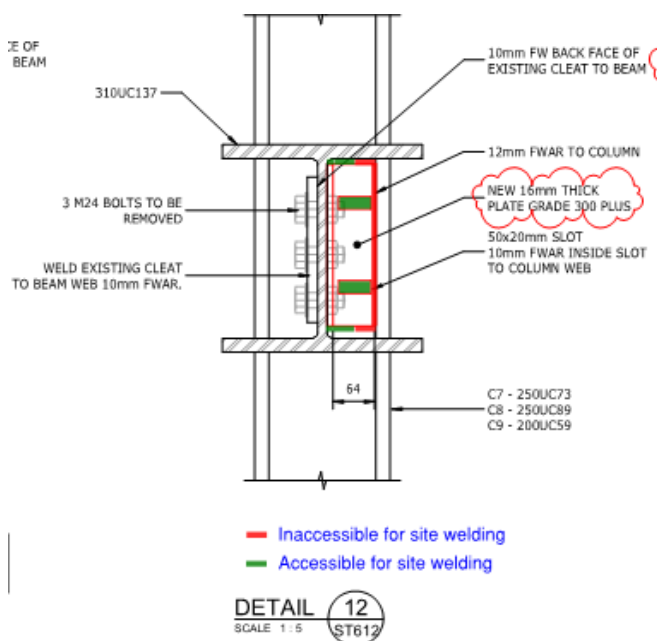

Figure 8 - Site welded beam connection

The drawings and specification are unclear with regards to the extent of painting proposed, and in particular what durability treatment is proposed to the Comflor decking. Given the C5-M marine environment, we recommend confirming the durability treatment proposed to the Comflor flooring system.

7 RECOMMENDATIONS

On the basis of our initial high level review of the structural documents provided, we have identified a number of concerns relating to design of the vertical and lateral stability system under the New Zealand Building Code (NZBC) B1/VM1, and relating to the expected durability performance to NZBC B2. A summary of these is as follows:

- Foundation bearing capacity appears insufficient to support gravity and seismic loads
- Lateral load resisting system lacks an obvious load path to develop floor forces, and appears to have insufficient capacity to resist the applied seismic loads
- New ramp separations proposed do not appear to address floor separations and raise a number of concerns regarding vertical load carrying capacity
- Floor slabs do not appear to be capable of anchoring the vehicle barriers proposed
- Stair support steelwork detailing does not appear to address lateral loads
- Steelwork remedial designs are impractical with regards to achieving durability requirements

From our high level review we believe there could be other aspects of the design that may not comply with the New Zealand Building Code. Based on this, it is our opinion that a detailed peer review should be carried out to understand the extent of the issues.

3. Substantive work on the construction project has been halted since early September 2019.
4. A Project Advisory Board has been established to ensure design and construction issues are addressed, [REDACTED], and learnings are identified.
5. The Project Advisory Board has identified a programme of work to be undertaken in advance of a substantive report back to Council in the first quarter of 2020. This report seeks endorsement of that programme of work.

DISCUSSION

Reasons for the Transport Hub project

6. The purpose of the Transport Hub project is to support the economic and social activity of the city centre by providing a facility that supports commuters and visitors wishing to access the business district by car, motorbike or bicycle.
7. The Transport Hub provides replacement carparking for sites that have been lost, e.g. The Strand southern reclamation (132 in 2014/15), University of Waikato Durham Street carparks (127 in 2014/15), and also for potential future developments, e.g. the ex-TV3 site (120 parks).
8. Additionally, the project provides the opportunity for Council to consolidate existing city centre parking space into one facility, freeing up valuable land for other purposes that will deliver a greater economic and social return for the city centre in the future, e.g. removing carparking from the waterfront.
9. The northern city centre location of the Transport Hub provides better parking options for the northern side of the city centre than currently exist.
10. A summary of the drivers for inclusion of the Transport Hub project in the Long-Term Plan 2015-25 was provided in the deliberations report (DC133, 2-5 June 2015). An extract from this summary is included as **Appendix 1** to this report as it provides useful background to the decision-making for this project. Key points made in this summary were:
 - (a) Demand for public parking in the city centre is high, in some areas too high to deliver an efficient service to our customers.
 - (b) Commuter demand for parking in the city centre is high, as many workers travel to work by car.
 - (c) Demand for leased space is greater than supply.
 - (d) There are a number of developments occurring and planned in the city centre that will increase parking demand.
 - (e) If significant investment is made in alternative transport modes there will be a shift in behaviour. However, the period until changes in travel behaviour occurs is likely to be medium-term.

Project background

11. During the Long-Term Plan 2015-25 deliberations, \$24 million was approved for the provision of a new off-street city centre northern carpark, the Transport Hub.
12. Through the preliminary design phase of the Transport Hub project during 2016 and 2017, a number of scope options were considered to maximise the space available for carparks, and for end-of-trip cycle facilities.
13. The final Transport Hub project scope was approved by Council in August 2017 and can be summarised as being:

To design and construct a nine-level Transport Hub on the existing Harington Street carpark area. The building is to comprise two basement levels and seven above-ground levels, accommodating 550 private vehicles and 250 cycles, and providing

charging facilities for electric vehicles and e-bikes, as well end-of-trip facilities for cyclists.

14. This option was selected as it maximises the site available. The two basement levels can be leased as premium secure covered carparks, and the number of above-ground levels is minimised which reduces, as far as possible, the impact on neighbouring properties.
15. A list of key Council reports regarding this project is provided in **Appendix 2**. These reports provide much of the background included in this report, including the strategic drivers for the Transport Hub project. The reports also contain detailed parking demand and supply information that, while now several years old, informed the decision-making process at the time and may also be of interest to this Council. Links to these reports have been separately circulated prior to this meeting.
16. In April 2017, **Harrison Grierson** was commissioned to carry out the structural design of the Transport Hub. The completed structural design was peer reviewed by an independent structural engineering consultant, **Constructure**, commissioned separately by TCC. The peer-reviewed design was lodged for building consent and consent was granted by the Building Consenting Authority, TCC, in July 2018.
17. Construction of the consented building commenced in May 2018, with a scheduled in-use date of December 2019. The construction is being undertaken by Watts & Hughes, with TSA Management providing an independent project manager acting for TCC. The balance of the project delivery team comprises the TCC Project Director, Warren & Mahoney Architects, Harrison Grierson providing structural design and Beca providing fire, building services and civil design.

Technical Issues

18. After a beam twisted under temporary construction loads in May 2019, Harrison Grierson carried out an internal review of their design and informed the TCC project team that they had identified an issue with the ramps in the building. At that stage, approximately two thirds of the structural steel had been erected and half of the concrete elements completed.
19. Whilst not expressly stated at the time, it became apparent that the issue related to the seismic resilience of the building. Harrison Grierson issued revised construction drawings for the building which included significant changes to the structure. These were again peer reviewed by Constructure. Based on the revised design, an amended building consent application was lodged and building consent issued in July 2019.
20. To provide additional assurance, TCC also commissioned **Holmes Consulting** to carry out a high-level structural design review of the recently redesigned building. Holmes Consulting has significant experience in the area of effects of seismic loads on buildings, particularly in Christchurch. Holmes Consulting's report of July 2019 highlighted a number of design shortcomings in the redesigned building, all of which were acknowledged by a new design team at Harrison Grierson. This process took some time while the new design team came up to speed with the complex model underlying the building design.
21. Substantive construction work was halted in early September 2019 and has not been recommenced. Since that time, various contract obligations and materials storage costs have continued at a round figure cost of \$4,000 per day to TCC. Additionally, as the Transport Hub was originally scheduled to open in December 2019 there is also an opportunity cost of potential lost carparking revenue.

Initial work to address the design issues

22. Around the same time as substantive construction work was halted, TCC appointed a team to work with the new Harrison Grierson design team and their new 3D structural modelling sub-consultant, **Compusoft Engineering**, to identify and quantify the design shortcomings. The TCC-appointed team comprises a technical advisor, **Dave Brunsdon** of **Kestrel Group**, Holmes Consulting and an independent peer reviewer, **Craig Stevenson** of **Aurecon**. Mr Brunsdon and Mr Stevenson are both highly experienced engineers. Mr Brunsdon also has extensive experience in the retrospective seismic strengthening of buildings. The TCC-

appointed team and Harrison Grierson-appointed team are together referred to as 'the review group'.

23. The review group has identified that the extent of the structural work required to address the design shortcomings includes:
 - work on the foundations;
 - work on the steel bracing elements;
 - separation of the ramp slabs;
 - additional reinforcement of the floor slabs; and
 - yet-to-be-finalised modifications to the slab edges and stair support details.
24. The redesign work is progressing and building consent is planned to be applied for in two stages:
 - (a) Foundation strengthening – application prior to Christmas 2019. The current status is that design and documentation has been completed and is now at peer review stage. Building consent application timing should be as planned.
 - (b) Superstructure strengthening – application by the end of February 2020. The design for this stage is currently underway and timing is currently running to plan.
25. Two matters are noted regarding the design issues and current building status:
 - (a) The focus to date has been on ensuring a robust design is arrived at, enabling the earliest possible completion of the Transport Hub to the high standard originally envisaged.
 - (b) Safety assessment of the partially-completed building is an ongoing process, undertaken by the construction contractor-appointed temporary works designer. This should be available by 20 December 2019.
26. The technical issues encountered with the building design and the process undertaken to address them are comprehensively covered in Mr Brunsdon's report, *Harington Street Transport Hub Background Report*, which is attached as **Appendix 3**.

Current and Proposed Programme for Resolution

27. On 9 December 2019 the Chief Executive drew together a Project Advisory Board (PAB) for the Transport Hub project to ensure:
 - (a) Design and build issues are resolved in the most timely and effective manner, enabling the build to recommence.
 - (b) [REDACTED]
 - (c) Learnings from this project are identified and used to improve TCC processes and practices.
28. The PAB's role is to advise the Chief Executive, enabling provision of the best decision-making information to Council regarding this project. The future of the PAB is to be considered once the objectives outlined above are achieved.
29. The PAB comprises the Chief Executive, General Manager: Strategy & Growth, General Manager: Infrastructure, General Manager: Corporate Services plus two independent experts in infrastructure projects and structural design, John Revington and Ian Fraser (to be confirmed). It is proposed that Mayor Tenby and Councillor Robson attend the PAB as observers, to ensure transparency of the process for the Mayor and Councillors. Council staff and independent technical and [REDACTED].
30. The workstreams identified by the PAB to date are:
 - (a) **Technical solutions** – already underway, as outlined in the Technical Issues section of this report. This workstream includes detailed costing of the potential solution or solutions.

- (b) **Strategic drivers** – the ‘why’ of this project. This involves both the project history, as briefly outlined in the Background section of this report, and examination of the current environment to incorporate any significant changes since the project was signed off.
- (c) **Financial analysis** – largely focuses on whole of life costs and revenues for the facility and the city centre parking network, including the impact of Council’s current and future parking pricing strategy on parking demand and revenue.

Note: a combination of outcomes from these first three workstreams will inform the range of alternate options Council might consider in the first quarter of 2020, alongside the option of continuing with the Transport Hub project as currently envisaged.

- (d) [REDACTED]

- (e) **Risk/ opportunity management** – the PAB will identify, assess and put steps in place to mitigate risk following standard TCC risk management processes.

- (f) **Communication plan** – [REDACTED], the part-completed Transport Hub and its structural design issues are understandably a matter of high community interest. The existing Transport Hub project communication plan is being updated to enable TCC staff, the Mayor and Councillors, and parties involved in this process to communicate clearly, accurately and consistently with our communities.

A draft set of key messages from this meeting will be circulated after the meeting concludes.

- (g) **Learnings implementation** – learnings from this project must be captured and built upon for the future. To this end each PAB meeting will note key learnings from this project for follow up at a later date. Once the more externally-focused workstreams are complete or near completion, the PAB will assess the learnings and approve an action plan to implement agreed improvements to TCC practices and processes. Ownership for each action will be assigned beyond the life of the PAB if required.

31. Council is asked to endorse the proposed programme for resolution at this meeting. This programme of work will enable a comprehensive report containing costed options for completion of the Transport Hub project, along with updates on related matters, to be provided to Council for a decision in the first quarter of 2020.

STRATEGIC / STATUTORY CONTEXT

32. The Transport Hub will provide multimodal transportation parking facilities, including undercover storage for 250 cycles and charging for E-bikes and electric cars, in alignment with the following plans, strategies and strategic initiatives:
 - (a) Government Policy Statement (GPS) on Land Transport 2018
 - (b) Draft Tauranga Transport Strategy
33. Provision of 550 carparks on a city centre site that previously provided 93 carparks enables some existing carpark facilities to be relocated to this site, freeing up valuable city centre land that may be better suited to other uses. It also enables future city centre developments’ carpark requirements to be met more effectively, encouraging and enabling more private city

centre development. This is in alignment with the following plans, strategies and strategic initiatives

- (a) Tauranga City Plan
- (b) City Centre Strategy
- (c) SmartGrowth Strategy
- (d) Tauranga Urban Form and Transport Initiative (UFTI)

FINANCIAL CONSIDERATIONS

- 34. The current approved budget for the Transport Hub project is \$32 million, with a further \$5 million currently included in the under-development draft annual plan 2021 budget.
- 35. Capital expenditure to date on the project is \$18 million, as at 30 November 2019, with around \$4,000 per day expenditure on various contract obligations continuing to add to that figure while construction is on hold.
- 36. No additional budget is sought at this stage, however there will potentially be financial considerations arising from a Council decision on the costed options report to Council in the first quarter of 2020.
- 37. Note that TCC’s currently adopted funding principle is that parking is a ring-fenced activity, which means that all parking costs are covered by parking revenue.

[REDACTED]

[REDACTED]

[REDACTED]

[REDACTED]

[REDACTED]

[REDACTED]

[REDACTED]

[REDACTED]

[REDACTED]

[REDACTED]

[REDACTED]

CONSULTATION / ENGAGEMENT

- 42. [REDACTED], there is understandably a high level of community interest in the project status and Council’s future plans for the Transport Hub.
- 43. A communication plan has been developed and is being updated. Key messages from this meeting will be circulated after the meeting concludes. These are referenced in paragraph 30, section (f) of this report.

SIGNIFICANCE

- 44. The ‘matter’ addressed in this report is the Transport Hub project. Any decisions relating to the ‘matter’ would likely be of high significance under the [TCC Significance and Engagement Policy](#).
- 45. However, the ‘decision’ sought in this report relates to endorsement of a programme of work that will ensure good information is provided to Council in the first quarter of 2020 to enable a Council decision on how best to proceed with the Transport Hub project build.

46. The 'decision' sought in this report, i.e. endorsement of the proposed programme of work, is determined to be of low significance.

NEXT STEPS

47. Next steps will be to continue with the proposed programme for resolution, as outlined in this report, with a view to reporting back to Council for a decision in the first quarter of 2020.

ATTACHMENTS

1. **Extract from Council report DC133, June 2015 - A11073427**
2. **List of previous reports to Council - A11073428**
3. **Kestrel Technical Background Report on Harington St Transport Hub - A11069339**
4. **[REDACTED]**

Extract from Council report DC133, Long Term Plan Deliberations 2-5 June 2015.

A summary of the drivers for inclusion of the Transport Hub project in the Long Term Plan 2015-25 has been reproduced below, largely as written in report DC133, as it provides a useful background summary of the decision-making information for this project.

1. Key background information from the earlier LTP Issues and Options Paper (DC24, 3 February 2015):
 - (a) Demand for public parking in the city centre is high at present – in some areas too high to deliver an efficient service to our customers.
 - (b) Commuter demand is being driven by the high number of workers travelling to work by car.
 - (c) Demand for leased spaces is greater than supply.
 - (d) There are a number of developments occurring that will increase parking demand.
 - (e) Under the current and proposed pricing regimes there is little interest from the private sector in partnering in the delivery of new public city centre parking facilities. A different parking pricing regime will generate more interest from the commercial sector.
 - (f) Parking is an integral part of the Tauranga Transport Strategy 2012-42, however if people are to be encouraged to use non-motorised transport they must be provided with a safe and pleasant environment. The creation of pedestrian and cycle links is an important part of increasing safety and access to the city centre. These links need to be planned and delivered in conjunction with road planning to enable the transport network to be developed in an integrated fashion.
 - (g) If significant investment is made in alternative transport modes there will be a shift in behaviour. However, the period until changes in travel behaviour occurs is likely to be medium term, but if parking prices remain suppressed then availability of spaces will create a supply issue that will need to be dealt with by the construction of new parking stock.
2. The need for new city centre parking stock is based on the following information:
 - (a) Most people visiting or working in the city centre come by car and use council-provided public car parking. This trend is unlikely to change for the foreseeable future. If this trend is not reversed traffic congestion will increase and parking availability will be reduced as more people commute into the city centre.
 - (b) The current occupancy of the city centre parking at peak times is 80%, however peak occupancy in the car park buildings is between 80% and 100%.
 - (c) Significant planned and future developments in the city centre mean that demand for parking will continue to grow.
 - (d) Having sufficient supply of public parking into the future provides certainty to users of the city centre and encourages investment.
3. Providing additional car parking facilities will generate an increase in single occupancy car use which, in turn, will place additional pressure on the local roading network. This 'demand and supply' approach to parking will also impact on the use of public transport and the level of investment considered necessary to improve and promote it.
4. The annual operating costs of a new \$24m parking building (primarily interest on debt and depreciation) would be \$1.4m.

5. Parking is a user pays activity. This means that the costs of running the parking activity are paid for by people parking across the city. The associated costs for the parking building would be funded through debt and repaid through parking charges and fines across the city, with no rates impact.

Previous substantive reports to Council

Meeting Date	Meeting	Report	Report Title	Objective ID
3 Feb 2015	Council – Draft LTP 2015-25 Deliberations	DC 24	Long Term Plan Issues and Options – Tauranga City Centre: Car Parking Building	A6080714 (agenda) A6066577 (minutes)
2-5 June 2015	Council – Long Term Plan 2015-25 Deliberations	DC133	City Centre: Car Park Facilities	A6291130 (agenda) A6295756 (minutes)
18 July 2017	Council	DC180	Harington Street Transport Hub – Scope Options	A8017950 (agenda) A8018473 (minutes)
15 Aug 2017	Council	M17/70.15	Notice of Motion – Transport Hub – Revocation of Resolution	A8069632 (agenda) A8084656 (minutes)
[REDACTED]	[REDACTED]	[REDACTED]	[REDACTED]	[REDACTED]
[REDACTED]	[REDACTED]	[REDACTED]	[REDACTED]	[REDACTED]

11 December 2019

Steve Wiggill
Project Director
Tauranga City Council
Private Bag 12022
Tauranga 3143

**Confidential and Legally Privileged:
Harrington Street Transport Hub – Technical Background Report**

Dear Steve

This background report provides a summary of the issues that have been encountered with the building design, the process undertaken to address them and the technical components of the project completion strategy.

1 The Original Design

1.1 Design objective

The original structural design objective was to achieve a building structure that complies with New Zealand Building Code Clause B1: *Structure*.

This objective is generally considered to have been met when a Building Consent is issued for the design, and a Code Compliance Certificate is issued upon the completion of construction to convey that the building has been constructed in accordance with the design. In issuing a Building Consent and Code Compliance Certificate, the Building Consent Authority draws upon a range of information, including engineering certification statements from the designers and peer reviewers.

1.2 Features of the building and its design

The Harrington Street Transport Hub is a nine-storey carpark building which comprises two basement levels and seven levels above ground. The overall plan dimensions of the building are approximately 55m by 37m. As is the case for many buildings in the Tauranga CBD, the underlying soils comprise silty sands and are of only moderate bearing capacity.

The structure comprises a reinforced concrete foundation ribbed slab foundation, and concrete basement retaining walls up to ground level. The superstructure consists of steel beams and columns, with concrete floor slabs that are cast in situ on metal decking.

Resistance to lateral loads is provided by diagonally braced steel frames in both the longitudinal and transverse directions. These frames feature a brace connection (INERD connection) which is intended to yield in a ductile manner and dissipate energy via replaceable pins at the ends of the diagonal braces.

Most aspects of the original design can be regarded as conventional in nature. The INERD connection is however an innovative feature that is not covered by design standards, and it is not known if these connections have previously been used in multi-storey buildings of this size in New Zealand.

1.3 Design and verification process

All structural aspects of the foundations and superstructure were designed by Harrison Grierson. A geotechnical investigation was undertaken and reported on by CMW Geosciences, and foundation design parameters provided to Harrison Grierson.

A regulatory peer review was undertaken by Auckland-based consultants Constructure, and they provided the Building Consent Authority (TCC) with a Producer Statement (PS2 – Design Review) which stated that they believed the building complied with New Zealand Building Code Clause B1: Structure.

A building consent was first issued by TCC on 16th July 2018, with a subsequent revision issued on 9th October 2018 (Amendment 1) to take account of a change in basement floor levels. Their consent review process would have relied upon the design documentation and certification from Harrison Grierson and the design review certification from Constructure to give them reasonable grounds to believe that the building complies with B1 Structure.

2 Identifying Issues with the Design

2.1 Discovery of the problem

After a steel beam on level 1.5 of the eastern perimeter twisted under temporary construction loads in May 2019, Harrison Grierson carried out an internal review of their design and informed the TCC project team that they had identified an issue with the ramps in the building. At that stage, approximately two thirds of the structural steel had been erected and half of the concrete elements completed. Whilst not expressly stated at the time, it became apparent that the issue related to the seismic resilience of the building.

In June 2019, Harrison Grierson issued a revision to the drawings for the building which included a number of changes to the structure, including remedial measures to the levels that had already been completed. They had identified that the customary floor separations had not been provided, and that the building would not respond to an earthquake in the way it had been modelled and bracing elements designed. The changes were peer reviewed by Constructure. Based on the revised design, an amended building consent application was lodged and building consent issued on 10th July 2019 (Amendment 4).

By that time however the TCC project team were losing confidence in several aspects of the structural design, and Holmes Consulting was commissioned to carry out a high-level structural design review of the recently re-designed building. Holmes Consulting is a leading national structural design consultancy with extensive experience in the seismic design and strengthening of major buildings. Holmes' review and report of July 2019 highlighted a number of design shortcomings.

The extent and implications of the design shortcomings identified by Holmes took some time to be fully appreciated and acknowledged by Harrison Grierson. This appeared to have been primarily because members of their original design team had subsequently left the company, and the new engineers took some time to become familiar with the complexities of the structural model and the innovative bracing connection system employed.

At the beginning of August 2019, Harrison Grierson accepted that there were significant issues with the design and acknowledged the points raised by Holmes Consulting. They established a design team which included a specialist structural modelling sub-consultant, Compusoft Engineering Ltd. Compusoft provide expertise in relation to the advanced seismic modelling of buildings, and their first task was to create a comprehensive new model of the lateral load resisting system.

2.2 Establishing the extent of the problems and required solutions

At the end of August, the TCC Project Director appointed the writer to provide independent advice to Council. The primary scope of this input was to address the following aspects:

1. Establishing and participating in a process to identify the full extent of the design shortcomings, including active liaison with all parties;
2. Facilitating discussions between all parties to develop viable solutions to return the building to fully code-complying status; and
3. Liaising with the regulatory arm of TCC to ensure that the revised building consent packages contained the appropriate information for timely consent processing.

In addressing the first two of these aspects, another highly experienced engineer, Craig Stevenson of Aurecon, was brought in at an early stage as an independent peer reviewer. It is appropriate to bring in a peer reviewer as early as possible, particularly in complex cases like this when it is essential to establish that the full scope of shortcomings have been identified.

Holmes Consulting also continued to provide inputs to the review of the original design.

3 Summary of Shortcomings in the Original Design

For the purposes of this report, the design shortcomings are grouped under the headings of *Foundations*, *Primary Lateral System* and *Other Elements*.

3.1 Foundations

The foundation slab has been found to have insufficient strength to be able to transfer the vertical loads from the columns to the ground. This lack of strength appears to have resulted from one of the provisions in the concrete design standard being overlooked.

3.2 Primary lateral system

A number of inter-related design issues have resulted in the original lateral bracing system to be found to be inadequate.

As noted above, car park ramps are typically separated in order for the different levels of the building to move relative to one another and enable the lateral loads to go to the primary bracing elements. Without this separation, a different load path results which sees the lateral forces taken in the ramps themselves – actions that neither the ramps nor the bracing structure were designed for. This issue had been identified by Harrison Grierson earlier in the year, but the movement joint they introduced did not provide for sufficient relative movement of the building between floors, given that the building had been designed as a ductile (ie. flexible) structure.

Creation of the separation of the ramp system also changes the response of the structure in other ways, resulting in different actions on the braced frames. As a result of the new model prepared by CompuSoft, a number of these elements have been found to not have the required strength and/ or ductility to resist the actions from the fully separated structure.

Other inadequate load paths to transfer the horizontal seismic loads from the floors to the main lateral bracing elements have also been found near the corners of the structure.

These shortcomings affect both the completed and still to be constructed levels of the building.

3.3 Other elements

Other relatively minor shortcomings were also found, including to the base connections of the vehicle barriers at the top and bottom of the ramps where they connect into to the edges of the concrete slabs.

The detailing of the support elements to the concrete stairs were not considered to fully take into account the full range of imposed seismic loadings from the stairs.

Having due regard to the design shortcomings identified through the Holmes review and subsequent process outlined above, it was apparent that the original design objective of a building structure that complied with the New Zealand Building Code Clause B1 had not been met.

4 Current Status of the Building

As noted above, the building is currently partially complete. Broadly, the structural steel framing has been constructed up to Level 4 on the southern side, Hamilton Street; the bracing elements have been constructed up to Level 7 on the northern side, Harington Street. The concrete floor and ramp slabs have been cast up to Level 4 above ground to the northern half of the building.

Construction of the main structure was halted on 3rd September 2019.

5 Strengthening of the Building to a Fully Code Compliant State

5.1 Extent of structural work required

In order to address the design shortcomings outlined in section 3, the following structural measures have been proposed:

Foundations

A new 350mm thick overlay slab across the whole basement will provide the originally intended foundation capacity. Associated work involves the drilling and grouting of a significant number of dowel bars into the existing slab to ensure the new and original concrete elements act together. The breaking out of an existing lower level ramp section is also required to enable access to the original slab.

Ramp slab separation

Separation of the ramps is being introduced to all the suspended floors above ground level on the western side of the building. Steel beams and columns are required to be introduced at each level to support the cut edge of the slab.

Bracing elements

New steel cross bracing elements are being introduced along each of the external faces of the building. The bracing components in two of the external corners of the building are also being replaced in the same location with new braces and connections. Associated work involves the reinforcing of the existing columns to the already constructed levels by the addition of welded steel plates. The connections of the existing columns in these bays to the basement walls are also to be upgraded, including the local reinforcement of sections of the basement walls.

Additional horizontal bracing is also being added to several bays of the roof.

Suspended floor slabs

Additional reinforcement of the floor slabs is required to accommodate the increased forces from the now-separated slabs. This will involve retrofitting the already cast slabs above ground, as well as modifying the design of the levels that are still to be cast. Strengthening of the connections to the steel bracing elements at the corners of the building is also envisaged.

Other elements

The extent of work required to the existing and new slab edges to accommodate the heavier duty vehicle barrier posts has yet to be determined, along with the modifications required to the stair support details.

5.2 The process and key participants

Harrison Grierson are responsible for the production of the calculations, drawings and specifications to reflect the above changes for the building consent and construction purposes.

It is understood that Compusoft Engineering Ltd have been engaged as a sub-consultant by Harrison Grierson to assist through until the completion of the design of the strengthening work. Geotechnical consultants CMW have also provided input in relation to the revised foundation design.

Independent peer review of the structural design work is being undertaken by Aurecon, led by Craig Stevenson.

5.3 Consenting process

It is intended that building consent for the strengthening work and changes to the levels that have still to be constructed will be applied for in two stages, as follows:

- Foundation strengthening – targeting submission of the consent documentation prior to the Christmas break.
- Superstructure strengthening – targeting submission of the consent documentation by the end of February 2020.

The intended programme through until the completion of the work is covered in a separate report.

5.4 Current Status of the Revised Design

The design is progressing towards the above consent submission dates. The foundation strengthening design and documentation has been completed and is currently subject to peer review.

The superstructure design has reached the point where the member design is essentially completed but the design and detailing of the connections is still underway.

It is understood that other minor aspects such as the revised detailing of elements including the vehicle barrier to slab connections and modified stair detailing has yet to be commenced.

5.5 Design issues and risks

It is understood that the architectural impacts of the proposed strengthening measures are minor and can be accommodated.

Technical issues and risks requiring further specific consideration include:

- Ensuring the durability of the structure is maintained, particularly in relation to the retrofitting of existing columns with site-welded steel additions.
- Verifying that the steel stored offsite during the site shutdown period has not deteriorated.

6. Concluding Observations

Once the project team became aware of issues with the design, it is considered that they have followed an appropriate and comprehensive process to understand the extent of the problems and take steps to produce a code-complying building. This has involved working through the stages of identifying the issues, quantifying the extent of the issues, agreeing on solution concepts and detailed design.

Outside specialists were involved at an early stage, firstly to establish the extent of the issues and then to provide the TCC project team with a level of confidence in the design processes employed by Harrison Grierson in developing appropriate strengthening solutions.

The level of external input being provided by CompuSoft (directly to Harrison Grierson) and Aurecon (as peer reviewer) plus Holmes Consulting is systematically addressing the issues with the original design and associated risks. There is a high level of confidence that a code-complying building that meets the original project objectives is being produced. The nature and extent of the remedial and strengthening measures are however complex, with cost and time implications that are outside the scope of this report.

Yours sincerely



Dave Brunsdon

Chartered Professional Engineer
DistFEngNZ

Director

Kestrel Group Ltd

Kestrel Overview Report on Harington St Transport Hub 20191211



Tauranga City

Harington Street Transport Hub Project Advisory Board

Project Status Report

For 28 January 2020



EXECUTIVE SUMMARY

- Nothing to report on Health and Safety.
- Conversation to be had [Board only session] regarding management structure and roles through to completion [see Agenda item 1].
- Good progress is being made on the strengthening re-design. Foundation consent lodged 10 January 2020. Super structure design will be completed w/c 10 February 2020.
- The Project QS and the Contractor are working through re-pricing the project and construction rescheduling as design develops, in order to optimise time. Budget and timing details are not definitive enough to report on.
- RLB is providing advice on the procurement approach to complete the building.
- [REDACTED]
- [REDACTED]
- [REDACTED]
- Communication with stakeholders is ongoing.
- Reporting to Council on 10 March 2020. The report will contain full details of the scope, cost and programme for completion of the building as originally planned and [REDACTED]

1. HEALTH AND SAFETY

Nothing to report. Minor enabling and non-abortive works ongoing. The TCC and Contractor H&S Advisors continue to carry out regular joint inspections.

2. STRENGTHENING DESIGN

Harrison Grierson continues to make progress on the strengthening design with modelling work being carried out by Compusoft, the local agents for the modelling software. TCC has appointed Aurecon to provide structural design peer review and a signed Producer Statement 2.

In order to reduce the total programme for design and design review, Aurecon is working closely with the Harrison Grierson and Compusoft teams. The entire re-design process is being closely monitored by the TCC team, with technical advice from Dave Brunsdon.

The foundation strengthening detailed design and peer review was completed on 9 January 2020 and lodged for Building Consent on 10 January 2020.

Since the PAB last met, Compusoft, Harrison Grierson and Aurecon identified that they could take a different approach to superstructure strengthening design which has slightly delayed the design programme but is expected to reduce construction cost and time. The design team have moved towards a 'special study' as permitted by the loading standard, as a valid but less onerous approach. Special studies are used quite commonly for more complex structures, and Compusoft and Aurecon have the required knowledge and experience to produce and review such designs. As a result, there is a significant reduction in the number of braces required overall, and in the nature of the foundation connections. No external bracing is now required to the street elevations of the building.

The updated re-design programme is shown on a separate document.

3. PROGRAMME

The re-design programme is detailed elsewhere.

The Contractor is developing a construction programme, simultaneous with design development.

4. FINANCIAL

4.1. Breakdown of Costs to Date [Action item from December PAB]

	2017	2018	2019	2020 (YTD)	Total
Professional Services	\$282,370	\$777,346	\$446,992	\$291,023	\$1,797,732
Construction		\$500,000	\$12,644,029	\$2,305,398	\$15,449,427
Internal	\$190,970	\$304,970	\$348,807	\$143,006	\$987,753
	\$473,340	\$1,582,317	\$13,439,828	\$2,739,427	\$18,234,912

4.2. Breakdown of Delay Costs [Action item from December PAB]

Cost Area	Monthly Cost	Daily Cost
Contractor	\$77,400	\$3,520
Consultants and Internal	\$35,000	\$1,590
Lost Revenue*	\$108,333	\$4,924
Total Daily Cost		\$10,034

* Original Revenue Budget for FY21 = \$1.3M (Assumed 85% uptake)

4.3. Revised Parking Opportunity Cost

The revised parking revenue budget for full year FY21 is \$600k. This is based on a staged take up of 25% on day 1 to 60% on day 365.

4.4. Costs Paid to Harrison Grierson by Year [Action item from December PAB]

Financial Year	Cost
2017	nil
2018	\$207,000
2019	\$175,000
2020 (YTD)	nil
Total	\$282,000

4.5. Strengthening Costs

RLB and Watts & Hughes are currently pricing the foundation strengthening costs in parallel.

As details of the superstructure strengthening design become available, these are being passed to RLB and Watts & Hughes for pricing.

Timeline for pricing by Steve Gracey, RLB New Zealand Managing Director, is included in the procurement advice note attached. The current RLB cost estimates include a contingency to reflect the cost estimate confidence level.

We will have these numbers ready to report at the Council meeting on 10 March 2020. These numbers will, however, be presented to the PAB for ratification prior.

5. [REDACTED]

6. STAKEHOLDER ENGAGEMENT/COMMUNICATIONS

The communications plan is reviewed regularly and updated as appropriate. It includes both planned and reactive communication material. We anticipate approaches from local media for an update on the project status in the very near future.

Regular stakeholder emails keep local affected parties informed of current and planned works.

Objective ID: A11153427

The most recent media coverage related to comments from a neighbouring property owner. The project team continues to work with individual property owners potentially affected by the works.

7. BUILDING PART-BUILT STABILITY

The shortcomings identified with the original design relate firstly to the foundation slab when all levels are constructed, and secondly to the performance of the seismic bracing under major earthquake loads (i.e. 1 in 500 year return period and above). These issues are not expected to cause concern when the structure does not have the mass from all the levels in place.

A lower level of earthquake loading is relevant for buildings under construction, even for situations such as this when the construction period continues for longer than anticipated (i.e. 1 in 250 year return period when the construction period exceeds six months).

The work to install relatively minor additional temporary bracing is currently being undertaken. This work will take the temporary structure to the 1 in 250 year return period.

8. COUNCIL MEETING – 10 MARCH 2020

The project team is currently preparing a report to the full Council meeting on 10 March commensurate with the original scope of the project. The report will contain full details of the scope, cost and programme for completion of the building as originally planned and some early guidance on the liability component, to inform decision-making.

9. RELATED DOCUMENTS:

9.1. Re-Design Programme

9.2. Current delivery Team Organisation Structure (for consideration)

9.3. [REDACTED]

9.4. [REDACTED]

9.5. [REDACTED]

9.6. RLB Procurement Advice (to be tabled)

9.7. Actions from PAB Meeting – 19 December 2019

Harington Street Transport Hub – Re-Design Programme

Activity	w/c 6 Jan	w/c 13 Jan	w/c 20 Jan	w/c 27 Jan	w/c 3 Feb	w/c 10 Feb	w/c 17 Feb	w/c 24 Feb	w/c 2 Mar	w/c 9 Mar	w/c 16 Mar	w/c 23 Mar	w/c 30 Mar
Foundation Building Consent Process													
Superstructure Design													
Superstructure Peer Review													
Superstructure Building Consent Process													
Foundation - QS Measure and Estimate													
Foundation - Contractor Pricing													
Superstructure - QS Measure and Estimate													
Superstructure - Contractor Pricing													
Overall QS Cost Estimate													
Overall Contractor Pricing													
Proposed PAB Meeting													
Council Decision													



Project Advisory Board Report.

Harington Street Car Park Project Project Manager's Report



Prepared By:

Malcolm Sabourin, TSA Management

Report Date:

2nd March 2020

1 Strengthening Design

Harrison and Grierson have provided the remedial works design for both the Foundations and Superstructure. The foundation design solution was lodged for a building consent on the 10th January and is currently under review by Aurecon as part of the Peer Review process.

The Superstructure Design Solution was provided by Harrison & Grierson on the 14th February which also included some amendment design for the foundation overlay. This design has been provided to Aurecon for their review in advance of progressing with the Building Consent. The peer review is anticipated to take 6 weeks to complete due to the complexity of the works required.

Structural design documentation is being reviewed for completeness by Watts and Hughes, assisted by the work carried out by RLB and TSA. The objective is to identify all remaining details and clarifications to ensure the building consent submission is fully complete and to allow RLB to complete an accurate cost estimate which can be used to compare against Watts & Hughes pricing.

2 Architecture, Traffic Design and Building Services

With the full extent of the structural strengthening works known this now allows the Architects Traffic Engineers and Building Services consultants to consider the implications and impacts of these additional elements and to develop their design responses. To ensure a coordinated approach is undertaken, TSA are managing regular meetings to progress this workstream. The outcome being, design documentation to support the Building Consent and to be provided to Watts and Hughes for subcontractor pricing.

Attached is a flow chart which outlines the general methodology for undertaking the design review within from key parties involved in this process.

3 Watts & Hughes Methodology and Temporary Works

Watts & Hughes with their structural subcontractors are now undertaking a detailed review of the structural design documentation and identifying areas where clarification of intent is required in addition, further details which are missing resulting in further update of the drawings. This is commonly found on projects and addressed during the construction phase. The intention is to identify these now such that there is a high level of confidence that the full scope of the works is captured and included in the pricing to be submitted by Watts & Hughes.

The required structural works are extensive and located within a partially completed building which introduces challenges of gaining access to undertake the works. In addition, the nature of the works will require a combination of:

- Significant temporary support of the structure where works are required within lower floors. The nature of this support anticipated to be more significant than the normal temporary works found during the construction phase of a project
- Complete removal of some elements where these are now redundant or member sizes have changed
- Deconstruction of portions of the structure to be taken offsite for remedial works where this provides a more cost efficient solution.

Watts & Hughes have now engaged with their key structural subcontractors and are developing methodologies to undertake the works. Once the general principals are established a temporary works engineer will be engaged to develop the temporary support structures.

The temporary works statements will assist with informing the project team and specifically the Quantity Surveyor in development of more accurate cost estimates.

4 Building Stability

During February we have received statements from both Watts and Hughes and Harrison & Grierson that the car park in its current condition is stable in both dead load and seismic loading conditions. The Watts & Hughes statement relates to floors which are partly constructed and the Harrison & Grierson statement relating to the basement which has been completed to their original design. The current loadings recognise that the substantial live loads from vehicle parking is not contributing to the loadings in the existing condition.

5 Strengthening Costs

During the period Watts & Hughes have progressed the pricing of the Foundation Design issued in January following consultation with their subcontractors on access to the lower levels and the methodology for these works. Delivery of long lengths of reinforcing steel to the lower levels will present challenges which will be reflected in the price expected early March.

Rider Levett Bucknall have received the superstructure design and have commenced scheduling the works in terms of quantities of materials. Cost estimates of the introduced structure is anticipated early march. As the Watts and Hughes construction methodology has not been fully developed this component of the works will prove difficult to price. This is a significant component of the required works and will attract a significant cost premium. For this reason we do not believe the RLB cost estimate will have a high level of confidence at this early stage of planning.

It is proposed to engage the services of a second Quantity Surveyor to undertake an independent cost estimate of the works. This initiative is supported, as we believe critical decisions will be based on estimated costs provide by the Quantity Surveyors rather than relying on Watts and Hughes to obtain fixed lump sums from their supplies and sub-contractors. In addition, it is anticipated that within the 6 week period during which the building consent peer review is carried out the Building Services and Architectural additional works will be designed but may not have been costed by the Watts & Hughes sub-contractors. Estimates will be required to inform on the cost of these works.

6 Programme

The design provided by Harrison & Grierson on the 14th February has provide a scope of works which is more significant and challenging in nature than was envisaged late in 2019. For this reason it is taking longer than anticipated for both the project team and Watts & Hughes to develop the methodologies by which the works will be carried out. In addition the Aurecon peer review of the superstructure is anticipated to take 5-6 weeks.

Based on information available to date and initial discussions with designers and Watts and Hughes we believe that a similar length of time will be required to allow Watts & Hughes and their subcontractors to develop pricing which includes the methodologies and temporary works associated with the current design.

The outline programme attached indicates that the earliest that the project team will have meaningful cost information including analysis of options is early May.

**HARRINGTON STREET CARPARK
STRUCTURAL STRENGTHENING DESIGN REVIEW PROCESS**

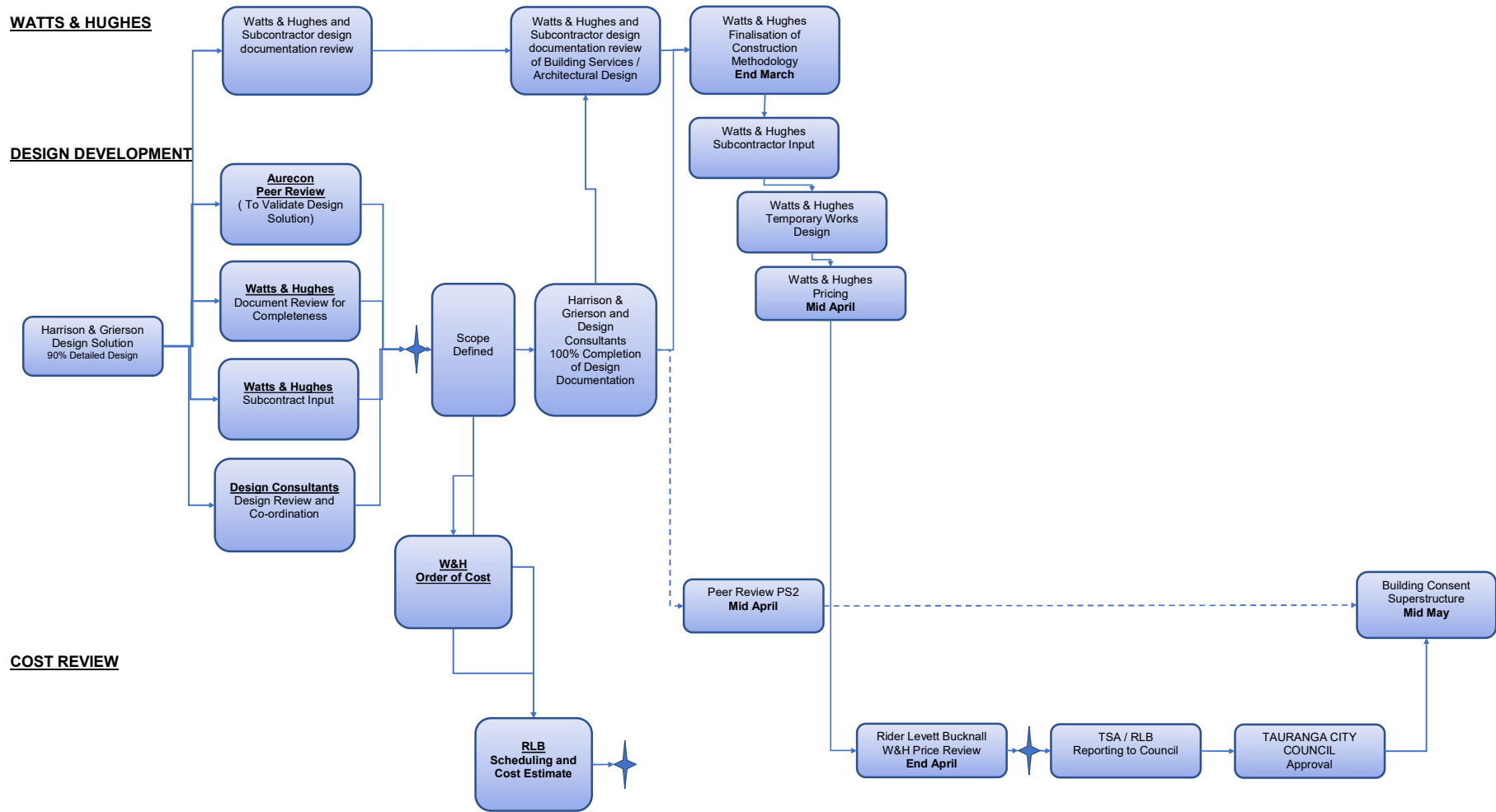

Harington Street Transport Hub Project Delivery Team

28 February 2020

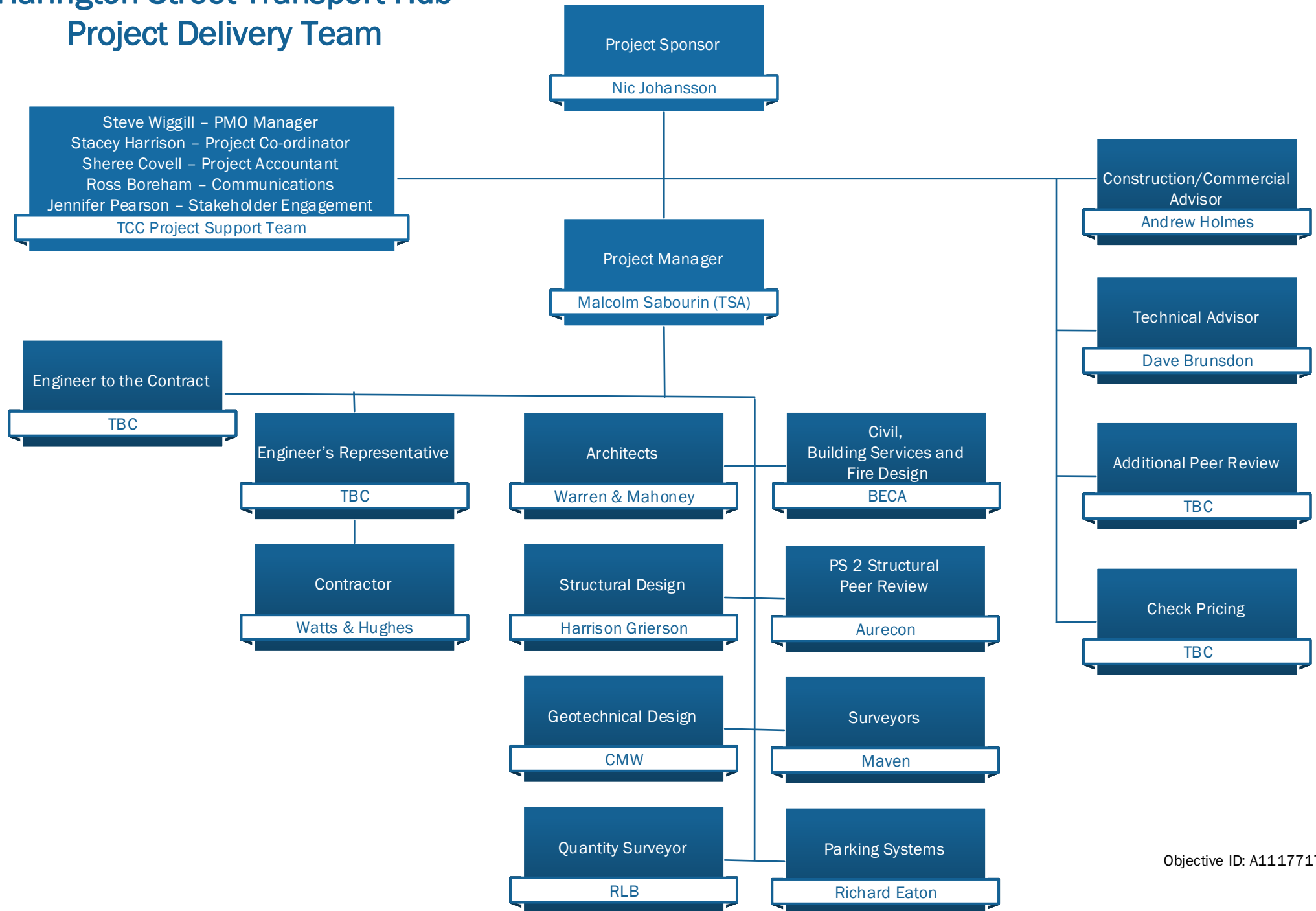



Tauranga City

Harington Street Transport Hub Project Advisory Board

Project Status Report

For 5th March 2020



EXECUTIVE SUMMARY

- Nothing to report on Health and Safety.
- A revised Project Structure has been developed and is currently being implemented
- The initial design packages for both the Foundations and Superstructure have been delivered by Watts & Hughes. These are being reviewed for completeness and further information requested where required to complete the design..
- The Project QS and the Contractor are working through re-pricing the additional structural works, rescheduling as design develops. Currently there is not the required level of construction methodology detail (under development by Watts & Hughes and their subcontractors) to provide accurate estimates for reporting to Council
- [REDACTED]
- Further communications with stakeholders is currently being prepared.
- [REDACTED]

1. HEALTH AND SAFETY

Nothing to report. Minor enabling and non-abortive works ongoing. The TCC and Contractor H&S Advisors continue to carry out regular joint inspections.

2. MANAGEMENT STRUCTURE

A revised management structure has been developed which provides for TSA to take a lead on the Project Management concentrating initially on the design development, interface with Watts and Hughes and establishing a cost to complete. Malcolm Sabourin of TSA is taking the lead to bolster the Project Management capability and is concentrating on the remobilisation period and progressing key activities to achieve a meaningful start to activities onsite. TSA's line of reporting is directly to Nick Johansson.

3. STRENGTHENING DESIGN

Harrison Grierson have completed their initial design deliverables for both the Foundations and Superstructure. Review by Watts and Hughes, TSA and RLB is underway to identify areas of further clarification and detail required,

The Extent and nature of the strengthening works has proven to be more extensive and demanding than initially anticipated.

Refer to TSA Report attached for further details.

4. PEER REVIEW PROCESS

(Action form 28th January Meeting)

The engagement of a fully independent Peer Reviewer in addition to the services being provided by Aurecon has been pursued. There has been some difficulty identifying suitably experienced companies who have capacity currently to undertake the works. An alternative approach using the services of Kestrel Consultants to review the process and close out of requests of clarification is being considered.

5. PROGRAMME

The programme through to reporting to Council on the all up cost of the works to complete has been reviewed and reforecast based on the extent and complexity of the works. These two components providing challenges in terms of the development of suitable methodologies and anticipated extensive temporary works design. It is anticipated that reporting with meaningful cost will not be available until early May 20.

The Contractor is developing a construction programme, simultaneous with design development.

6. FINANCIAL

6.1. Breakdown of Costs to Date [Action item from December PAB]

	2017	2018	2019	2020 (YTD)	Total
Professional Services	\$282,370	\$777,346	\$446,992	\$291,023	\$1,797,732
Construction		\$500,000	\$12,644,029	\$2,556,316	\$15,700,345
Internal	\$190,970	\$304,970	\$348,807	\$156,706	\$1,001,453
	\$473,340	\$1,582,317	\$13,439,828	\$3,004,045	\$18,499,530

6.2. Strengthening Costs

RLB and Watts & Hughes are currently pricing the foundation strengthening costs in parallel. Watts and Hughes have advised that they will have their methodology statement, cost of works and programme available by the week commencing 9th March 20.

(Action from 28th January meeting)

Project Cost Estimates

The Superstructure design is currently being measured in detail by RLB and will closely be followed by the estimate for the works. Currently there is inadequate information to place cost estimates with any level of certainty on the temporary works components of the works. This will only be possible once Watts & Hughes progress their temporary works design.

RLB advise that they plan to have an update estimate by the week commencing 9th March 20. This estimate to be reviewed as more detail becomes available.

Currently engagement of a second Quantity Surveying company to provide a comparison in cost estimating of the works has been pursued. Discussions are underway with Cuesko.

Refer to TSA Report for additional detail

7. [REDACTED]

8. STAKEHOLDER ENGAGEMENT/COMMUNICATIONS

The communications plan is reviewed regularly and updated as appropriate. It includes both planned and reactive communication material. We anticipate approaches from local media for an update on the project status in the very near future.

The communications team are preparing for a further media update on the project which was previously advised would occur early 2020

9. BUILDING PART-BUILT STABILITY

(Action from 28th January meeting)

Council have received advice from Watts and Hughes confirming that the portion of the building above ground which is partially complete is in a stable condition during appropriate return periods for structures under construction

Harrison & Grierson have reviewed the portions of the building which have been completed to their original design and confirm that the structure is stable under both gravity and seismic loading on the basis that the car park floors do not have the applied live load of vehicles.

10. LGA – OPTIONS STUDY

(Action Item from 28th Jan 2020)

As required under the LGA a number of options are being considered and order of cost estimates prepared by RLB. These include:

- Removal of 4 floors of the building with resulting reduced
- Deconstruct total and backfill to ground level
- Deconstruct and rebuild

High level costings have been received from RLB. These can be compared to the structural strengthening option in advance of final reporting to Council in May.

11. COUNCIL MEETING – 10 MARCH 2020

It was envisaged that a report would be taken to Council on 10 March with costed options and a recommendation. However the design delivered by Harrison and Grierson on the 14th February has provided a challenging design solution which is currently being considered in detail by Watts & Hughes and their specialist sub-contractors. The resulting development of appropriate methodologies and temporary works solutions means that an update to Council will not be achievable in March. A more realistic date being May this year. This timing to be discussed further at the PAB meeting.

12. RELATED DOCUMENTS:

- 12.1.** TSA Report
- 12.2.** Re-Design Programme
- 12.3.** Design Process Methodology Flow Diagram
- 12.4.** Current delivery Team Organisation Structure

Project Name: Harington Street Transport Hub
To: Nick Johansson / James Woodward (TCC)
Prepared by: Malcolm Sabourin TSA
Subject: Status Update Report Report
Report Period: To: Friday 3rd April

1.0 **OVERVIEW**

Current Programme Objectives

The current emphasis is to be able to report back to the PAB on the following primary areas of focus:

- Resolution of outstanding H&G design issues which are needed for Aurecon to complete the Peer Review.
- Consideration of Holmes Group alternative concept design solutions for bracing within the structure
- Watts & Hughes Pricing of the works
- Cost Estimates to complement the W&H Pricing should fixed lump sum not be achievable.
- Costings for the following Options:
 - Design as documented
 - Reduction by 4 floors
 - Demolition to leave a basement ready for future development of the site
 - Demolition and rebuild of carpark using a conventional structure

During the Covid 19 isolation period the activities which can be undertaken remotely have continued to progress utilising Skype and Teams conferencing techniques. This is working well however Watts and Hughes have found it challenging to engage with subcontractors who ideally need to visit site to view the scope of work elements and the environment in which they will be working. This is likely to impact on the ability for Watts and Hughes to provide a lump sum figure without a series of risk premiums added to reflect the level of fixed pricing information available ..

The following work streams have progressed during the last week in the lead up to reporting to the PAB at a meeting now scheduled for the 23rd April.

- i. Aurecon Peer Review of the Superstructure
- ii. Watts and Hughes development of temporary works
- iii. Watts and Hughes pricing of the works
- iv. Rider Levett Bucknall cost estimating of the works
- v. Cuesko cost estimating of the works
- vi. Architectural and Building services changes due to structural works
- vii. Independent Structural development of alternative bracing concept designs by Holmes Consulting Group.

Harrison & Grierson are still developing a design solution for the superstructure as questions are raised by Aurecon. We are not simply answering minor queries but are essentially still designing which is slowing the peer review process.

Programme

We are now planning towards completing work steams as best we can under the Covid 19 constraints to allow reporting to the PAB on the 23rd April.

2.0

DESIGN

Independent Design Review

- A concept design workshop was held on Wed 1st April and attended by; Holmes Group, Harrison and Grierson, Compusoft, Kestral and TSA. Holmes Group tabled three options for discussion. These consist of:
 - Option 1 – Nominally Ductile Concrete Shear Walls. - This option is likely to require a large foundation in the Basement which would reduce carpark numbers but provides a clean solution and gets rid of our seismic joint on the ramps
 - Option 2 – Ductile Concrete Shear Walls only to the perimeter walls on grids 1 and 7 . This utilises shear walls to the perimeter and maintains the seismic joints to ramps. Car park numbers are maintained.
 - Option 3- Similar concept as 2 but uses Structural Steel Bracing
- Each of these provided promising alternative designs in the longitudinal plane of the building which would replace the current steel strengthening at the corners within the basement. All three options remain as viable design solutions for longitudinal strengthening.

The transverse direction is more challenging and although an alternative solution was discussed it appears that the utilisation of the INERD frames and pins will still be required as will the strengthening of columns

- Following on from this workshop Holmes Group will further develop their broad concepts and annotate mark ups. These will be used to obtain some broad estimates of cost to establish whether one of these provides an overall solution which could provide a feasible alternative to the current Harrison & Grierson Design.

The concepts put forward by Holmes Group seem promising however access to construct will require careful consideration. At some point input will be required from Watts and Hughes however currently we do not want to introduce this complexity and redirect the focus away from finalising a cost for the current design. Furthermore, key subcontractors may become disinterested if they are aware alternatives are being considered. Cost estimates provided by RLB are possibly the best way forward for use and throwing into the mix as part of the Options study.

Building Services to Basement as a result of 350mm overlay

- The design consultants have completed their concepts for building services and architectural elements which are required due to the additional structural works introduced by Harrison and Grierson.
 - Further development of these has been held as we wish to minimise fees expenditure until a decision is made on which option/s Council wish to progress further.
 - The information developed to date is adequate to feed into the cost estimate to be provided by Rider Levett Bucknall
-

3.0 **BUILDING CONSENTS**

Foundations:

The revised design for the foundations has been received with the PS1 and PS2. This is ready for submission to Council . TSA are following up on some earlier clarifications generated by Council so that these also can be included with this revision.

Building Superstructure

As reported in the last period it has been necessary for the H&G structural model to be rerun to reflect the as-built form that exists onsite. This has been completed which then required a review of the outputs followed by any resulting change in design.

There are numerous areas where further clarification of design detail is required however as indicated previously there remain three areas where a design solution appears to be challenging.

These include:

- Ductile Pins – Final extent of pin remedial works
- Splice plates to columns – The practicality of achieving what is required
- Slab Diaphragm

There continues to be dialog between Harrison & Grierson and Aurecon to clear RFI's generated through the Peer Review process.

As we have identified earlier we appear to remain in a state where elements of the structural strengthening are still in a design phase as the issues above have not been resolved to the Peer Reviewers satisfaction. Furthermore the information which will emerge once this design is resolved is urgently needed to feed into the pricing and cost estimating process.

4.0 **WATTS & HUGHES**

Temporary Works

We are advised that the temporary works design was substantially completed last week and provided to Watts & Hughes for final review. During the coming week it is intended:

- Watts and Hughes to utilise this information to incorporate into their costings for the overall works
- The temporary works designs to be circulated to both Rider Levett Bucknall and Cuesko to provide a better understanding of the complexities of undertaking the works required and therefore reflect this in the estimates they are developing.
- Provide Council and the technical consultants and better appreciation of what is required.

Construction Methodologies

Detailed construction methodologies can now be progressed with the temporary works designs completed. It should be noted however that due to the Covid 19 access restrictions there will remain areas of works for which final resolution of details will not be fully developed. Examples of these are likely to include:

- Finalisation of acoustic walls required to control noise breakout to achieve maximum boundary noise level. The works generating excessive noise levels include:
 - a. Drilling of dowels within the basement for the slab overlay.
Currently within the limits for a small number of tools being operated but likely to be exceeded when multiplied by the numbers required to achieve meaningful progress.

b. Hydro Excavation

Hydro excavation of the concrete at the top of the basement walls to achieve the design solution. To undertake these works relaxation of Council noise limitations would be helpful however this is unlikely to be achievable due to the relationship with adjacent neighbours.

c. Sandblasting

Sandblasting of structural steelwork to remove existing paint systems where steel plating is required to strengthen the columns and where the existing steelwork primer is likely to require replacement due to the length of time the steelwork has been left in an exposed condition. Extent and ability to control noise break out yet to be resolved.

Buildability

It has not been possible for Watts & Hughes to engage onsite with subcontractors to view and discuss how works maybe carried out to achieve the required design outcome. Engaging with subcontractors is challenging and relies on phone and skype communications which is not ideal.

- The primary subcontractor is Jensens who are critical in terms of reviewing the steel design as it is produced. Although their senior management have been tied up in some essential construction projects they have provided initial feedback identifying concerns on details which are now being developed for the splice and plating of the steel columns. We have been advised that what is being proposed is not able to be achieved onsite and as such we have asked both H&G and Aurecon to “hold” further peer review of these elements until buildability can be resolved. A skype meeting using photographs of typical connections is being arranged for next week to determine a solution which reflects the access constraints of achieving what is required. Once resolved the design can be provided to both Aurecon to complete the Peer Review and our Quantity Surveyors for cost estimating purposes.
- It is likely that progressive removal from site of components requiring modification will be required to achieve a cost efficient solution. In addition, where close tolerances are to be achieved, this maybe the only practical solution. The extent of this removal will become clearer once the methodology statements have been developed in more detail.

Site Security

Watts and Hughes have secured the site and are now working from home.

During the past week visits have been carried out to maintain pumps operational onsite and to check overall security of the site. There have been no issues identified as a result of these inspections.

5.0

FINANCIAL

Financial Work Stream 1 – Watts and Hughes Pricing

- Watts and Hughes ability to engage with their subcontractors and suppliers onsite to develop detailed methodologies and solutions to aid in pricing the works is no longer possible during the isolation period. This is limiting their ability to formulate fixed price lump sums for elements of the works.
 - TSA have asked Watts & Hughes to provide a work in progress summary of their pricing which includes those trades and components of works which can be priced and those which are proving to be an issue.
-

- As identified in the previous report there is some reluctance by certain subcontractors to take on risk where extent of works is not fully known. In addition access to undertake the works with unknown productivity rates is likely to result in elevated prices.

Financial Work Stream 2 – Rider Levett Bucknall Cost Estimating –

- RLB continue to be provided with more detailed information from which to develop their cost estimate for the current design solution.

Financial Work Stream 3 – Cuesko Independent Structural Cost Estimate

- The RLB schedule descriptions and design documents have been issued to Cuesko
- TSA have marked up a set of structural drawings to assist Cuesko with their understanding of the works required including the extent of structure complete for pricing the demolition option.
- A scoping meeting has been carried out with Cuesko and RLB in the last week to ensure both parties have a consistent brief and have access to the same information.

Financial Work Stream 4 – Options Studies

The following Options Studies are being prepared for the PAB and Council so that further financial modelling can be undertaken to assist in decision making:

- Option 1 – Current design solution
- Option 2 – Reduction in height by 4 floors
- Option 3 - Demolition leaving only a basement
- Option 4 – Demolition and rebuild carpark using a conventional structural solution.

The estimates available for Option 1 will be more accurate due to the more detailed information available. Costs for the remaining options will be high level but are aimed at allowing decisions to be made on an order of cost basis.

The Cuesko contribution into Option 1 has been limited to structural works as this is where the majority of cost lies, and their input can provide best value for money. Their further contribution will be to provide a cost estimate for Options 3 and 4.

The information available for option 2 is limited as H&G will be required to undertake detailed modelling to establish any reduction in strengthening requirements. Currently their resource is fully committed to establishing a design solution for Option 1.

RISKS -New Risks Identified in Bold

Emerging Key Risks	Risk	Rating	Mitigation
	<u>Achieving Design Solution</u> There is a risk that there is not a practical and economical solution to resolve the three fundamental areas of design which include: <ul style="list-style-type: none"> • Pin and associated plate modifications • Diaphragm action 	Med / High	H&G are responding to Aurecon RFI's challenging the design. Buildability advice is being sought from Jensen's to ensure that the design solution can be achieved

- **Splice and Column Joints**

<u>Steel Primer</u> There is a risk that the steel primer on the upper levels is no longer effective due to the length of time it has been exposed and will require replacement	High	Testing proposed to try and determine extent of the issue . An estimate of extent will need to be the basis of the W&H pricing.
<u>Noise and Dust</u> Should replacement of the primer be required this is require sandblasting to prepare the surface. The noise levels will exceed boundary maximum levels	High	Watts & Hughes enlisting the advice of an acoustic engineer to advise on noise containment initiatives Extent of acoustic isolation walls being investigated
<u>Hydro excavation</u> There is a risk that the noise levels resulting from using Hydro Excavation techniques will exceed the permissible maximum boundary levels	High	Watts & Hughes consulting with an acoustic engineer to develop noise screening methodologies.
<u>Cost Certainty</u> There is a risk that either extent of works or methodologies present risk to subcontractor result in subcontractors not being willing to fix there prices	Medium	Watts & Hughes being advised that Councils expectation is that a fixed price lump sum is required to keep pressure on for an acceptable price submission.

KEY ISSUES

- Investigation through independent advice of an alternative bracing system with the aim of simplification and reduced construction time / cost – Concepts to be estimated to determine order of cost for comparison against the base scheme
 - Development of parallel cost estimates -Underway
 - Close out of Superstructure Peer Review and design which impacts on final pricing of the works - Ongoing.
-



Tauranga City

Harington Street Transport Hub Project Advisory Board

Tauranga City Council Update

For 23rd April 2020

This sponsor's report outlines Tauranga City Council's parallel workstreams running alongside the technical work being undertaken by TSA, and [REDACTED] (both reported separately). These parallel workstreams include:

- Strategic Review & Decision Making
- Financial Modelling
- Communications

The plan is to provide enough detail and evidence with technical work, financial modelling, [REDACTED] and strategic support to place Council in a position to understand benefits, costs, risks and consequences for the various options to be considered and decided upon.

The communications support will advise on messaging locally and nationally, give clarity on associated risks, reputational issues and potential consequences.

The financial modelling has been completed and is based on the estimates provided by the work undertaken on the options by TSA.

The original design is technically very demanding. It is proving extremely difficult to design structural strengthening solutions to deal with the seismic deficiencies, let alone design them to be retrofitted on site. The result, after analysing the original design principles and alternative options, is that there are no cost-effective solutions. The team concludes a drastic picture of cost, time and effort. The detail is covered in the TSA project managers report.

The design, technical work and costings could continue in order to provide greater detail, and possibly better certainty, but at diminishing returns.

The project team is proposing that it is presenting to the PAB a suite of information which can turn the focus to looking at what is the best option for Council to pursue the information now available providing both the PAB and ultimately Council enough confidence to make an informed decision.

We suggest that the work being undertaken by Stakeholder Strategies will help assist in this process by giving the full picture of criteria to be considered.

Strategic Review & Decision Making

Stakeholder Strategies has been engaged to assist TCC in finding the most suitable way forward for the project. The three essential tasks covered off in their scope of work are:

1. Why did TCC decide to build this project; does that decision apply today?
2. What are the forward options and which out of those is most attractive.
3. What are the criteria that Council need to consider to decide on a path forward.

TCC have provided Stakeholder Strategies with all current available information to assist them with answering the above questions. Stakeholder Strategies have also conducted interviews with key individuals who were involved in the project’s planning and development.

Attached in the appendices is the current scope and indicative information required to answer the above questions.

Financial Modelling

The table below shows some high level financial modelling of scenarios. All options will deliver a negative return based on the current pricing structure and would need significant price increases to make them financially viable. These increases range from 10% to 20% year on year, which in itself would significantly influence private car park supply together with demand making these models unlikely to be sustainable.

At current pricing levels (inflated going forward) the maximum cost of the car park could not exceed \$25m (or for the lesser floor model less than \$15m). These are based on uptake models which are difficult to predict in the current environment but show the clear gap between existing costings and a sustainable outcome.

		Total Project cost	Completion	Number of spaces	ROI using 2020 fees (50 years)	ROI using 2020 fees (30 years)	Fee increase required to achieve 4 ROI (50 years)	Fee increase required to achieve 4 ROI (50 years)
Option A	Redmediation	53,400,000	Mar-22	550	-67%	-82%	9.90%	13.60%
Option B	Demo	24,900,000	Dec-20	0	0%	0%	NA	NA
Option C	Demo & Rebuild	62,100,000	Nov-22	550	-73%	-80%	11.65%	14.90%
Option D	Reduced Height	47,644,000	Nov-21	278	-87%	-91%	16.20%	19.50%

Communications

On 9 March 2020, a media release was published providing an update on the current state of the project. The release stated that it was anticipated that council would consider recommencement options by mid-year.

No further updates have been provided to the media in the interim.

Once the PAB has determined that it is ready to recommend options for the future of the building to Council, it is expected that a 'holding release' would be issued, with a detailed update prepared for release once the Council has made a decision. Assuming that process would be in a public excluded meeting of Council, the release would first be shared on a confidential basis with key stakeholders (including elected members and Council's senior leadership team) and then shortly after, be released simultaneously to other stakeholders and to media representatives. It is anticipated that the spokespeople providing background to the Council's decision would be the General Manager Infrastructure (technical detail and option selection), the Chief Executive and the Mayor or PSOC chair.

1. RELATED DOCUMENTS:

1.1. Stakeholder Strategies Scope

Memorandum

To: Project Advisory Board
CC: [Copied recipient name/s]
From: David Cunliffe, Partner, Stakeholder Strategies
Date: 17 April 2020

Scope of Stakeholder Strategies engagement on Transport Hub project

This note is a summary of the scope of work Tauranga City Council has engaged Stakeholder Strategies to carry out. Due to the time frame of the assignment, wherever possible we are relying on data and modelling that already exists.

The three essential tasks covered within our scope are outlined below, along some sub-questions that may be explored within each of these three headings, pending availability of information and importance to outcome. We expect these sub-questions will evolve as insights emerge.

1. Why did Tauranga decide to build the Transport Hub, and would it make the same decision today?
 - What was the original rationale for the carpark project and how did that evolve?
 - How cogent was the rationale given information at the time?
 - How was the procurement process managed and how were providers contracted? Was this process effective?
 - Is the original rationale for the Transport Hub supported by current strategies, including the transport and city center strategies?
2. What are the forward options and which is most attractive?
 - What are the options and what are the costs and risks/uncertainties associated with each? (taking Project Advisory Board outputs as our inputs)
 - What are the high-level constraints of these options, and can they be navigated?
 - How should the options be assessed?
 - Multi-criteria decision analysis?
 - Risk-adjusted decision analysis?
 - What option/s appear most favourable?
3. How can Council decide on a path forward?
 - When and how should decision be made by Council as to the path forward for the Transport Hub project?
 - What option is preferred and why?
 - How should conditions and constraints be navigated?
 - What are the political and management considerations?
 - How should a decision be communicated (high level)?



Project Advisory Board Report.

Harington Street Car Park Project Project Manager's Report



Prepared By:

Malcolm Sabourin, TSA Management

Report Date:

20th April 2020

1 Summary

1.1 Structural Strengthening Work Stream

- Aurecon continue to challenge H&G's design solutions in critical areas which is delaying finalising the Superstructure Peer Review process and impacts generally on making progress overall. The latest advice received indicates that the design / peer review process will take another 3 weeks to reach a point where documents will be fully available for Building Consent. A further 3 weeks is required for Watts & Hughes pricing.
- Alternative bracing systems have been identified and should be progressed if the project is proven to remain viable at current cost estimates.
- The works are challenging and controlling noise level at the boundaries of the site requires further work to prove feasibility.
- On completion of the strengthening, the remedial works will likely be visible and difficult to conceal.
- Alternative Option cost estimates have been prepared based on available information from which to feasibility studies can be developed. TSA recommend that Council review the current \$53.4 estimated value and determine whether the project remains viable compared to the other options being considered.

1.2 General Items

- Watts & Hughes have followed the Governments Covid Level 4 directive which required all non-essential construction sites to close. Subsequently we have received formal notification as required under the Contract. [REDACTED]
- Watts and Hughes remain responsible for the security of the site and have undertaking periodic inspections in a manner which conforms with physical distancing guidelines.
- Future additional costs for compliance with any new Covid-19 working regulations or standards are likely to be treated as variation under the Contract and become a project cost.

2 Strengthening Design / Peer Review

The superstructure design was issued by Harrison & Grierson to Aurecon for Peer review on the 14th February 2020. The key components of this design being:

- Basement wall strengthening in four corners
- New Seismic Joint to Ramps from level 1.5 to the roof and externally within the building envelope. This includes introduction of new columns and beams to create the ramp seismic joints.
- Introduction of carbon fibre wrap over the entire area of slabs at levels L 01.5 and L 02
- Extensive Beam column connection strengthening above Level L 01.5
- Extensive plating up of columns to provide the required capacity
- Replacement of Inerd pins and gusset plates within the existing bracing bays located at the 4 corners of the building.

As of writing this report Aurecon have not been able to complete their Peer Review as there continue to be significant areas where the design is being challenged and Harrison & Grierson are being required to review and redesign their solutions. Buildability has also been challenged by the steelwork subcontractor resulting in the necessity amend the detailing of strengthening components to achieve the required outcome.

In summary we are still developing a design solution for the strengthening of the building which is over and above that which is normally expected during a peer review process. This has impacted on the ability for Watts and Hughes to have their subcontractors' price the works.

Key areas of design which remain unresolved include:

- The capacity of the design to transfer vertical loads between the superstructure and the basement wall strengthening
- The capacity of the carbon fibre overlay required to strengthen the diaphragm slabs at L 01.5 and L 02
- Capacity of the Inderd pin gusset plates forming part of the seismic bracing system.

TSA are in daily contact with both H&G and Aurecon to monitor the flow of information and achieving commitments for documentation milestones. In addition, we have consulted with higher management within H&G to voice concerns over progress and request that the technical support to the local office is maintained to ensure that the design issues are resolved without delay.

The 350mm foundation to be poured over the existing lower basement level has been designed and the peer review completed. This is now ready for documents to be submitted as an amendment to the original consent. This overlay results in the clearance to the underside of the beams reducing to 2.2m. This satisfies the minimum requirements of the District Plan, however will place limitations on the type of vehicle which can use the lower levels

Building services and architectural works which are required as a result of the structural additions have been progressed to a level of detail required for the purposes of preparing cost estimates. Further development of these works is being held until structural design has been completed and the direction of the project confirmed.

3 Traffic Design Review

The traffic consultants (Abley) have completed a review of the carpark layout as requested by the PAB. The objective was to validate that the final design reflects Council's expectation that the parking, circulation and general layout provides a facility that is functional and as a minimum complies with the District Plan.

The review has confirmed

Standard Parking Bays

- i. Parking bay depths comply with both the District Plan and AS/NZS 2890 at 5.4m
- ii. Parking bay widths at 2.5m comply with the District Plan but are less than AS/NZS 2890 which recommends 2.6m width. The Abley report advises that the parking bay widths at 2.5 are still acceptable.
- iii. Isle width is generous at 7.5m where the code and District Plan require 5.8

Disabled Parking Bays

- iv. Parking bay depth of 5.35m complies with the ANZ/NZS 2890
- v. Parking bay widths at 2.5m comply with AS/NZS 2890
- vi. The shared space width of 1.0m as dimensioned on the architectural drawings is less than the 1.1m required under the code. The architectural layouts indicate that a dimension of at least 1.1m is possible. The question has been asked of WAM to confirm a wider shared space can be achieved.

Abley have made suggestions for signage to be provided on level L 01.5 Harington Street entrance level where there is potential for cyclists to share isles with vehicles. This can be accommodated however it is noted that the intended primary access for bicycles is via the dedicated ramps of Hamilton street directly into the cyclist facilities. It is recommended that the Abley report be provided to relevant stakeholders within Council who may not have been involved with the original design and decision making process for the purposes of informing on the final internal traffic design solution.

4 Construction Challenges

Watts & Hughes continue to work proactively to support the project and have developed methodologies and temporary works designs for the strengthening works. Pricing has not progressed as planned due to the ongoing change in structural design. In addition, the Covid -19 lockdown has impacted on the ability for subcontractors to visit the site to understand; the scope of works required, the means of access and have meaningful dialog required to prepare pricing for Watts and Hughes.

There remain some key areas of construction risk which are proving difficult to mitigate and resolve. An example being the hydro-excavation of the basement walls and sandblasting to prepare for plating up of columns and to address deterioration of primer to steel components where these have been left exposed for an extended period. The equipment used to undertake these tasks generate high noise levels which will require temporary acoustic walls and screening on grids 1 and 7 to reduce the impact on the neighbours. Acoustic advice has been sought and the type of temporary works construction to form a screen along the boundaries has been identified. It may in some instances be necessary and be more cost effective to deconstruct these elements and have the sandblasting undertaken offsite.

As part of the column strengthening steel plates are required which pass through the existing completed concrete slabs. To achieve this, concrete will be required to be removed to gain access and then repaired on completion. Similar complexities exist where beam / column joints need strengthening. Reinstatement on completion of the works will leave evidence of a repair which is not desirable in a new building.

The works require a significant onsite resource to undertake the strengthening. Yet to be factored into productivity and cost is the impact that the Covid-19 work practices will have on the manner in which the work force can operate onsite. Guidelines are being developed but based on Australian experience productivity rates can be expected to reduce and costs increase as a result. We anticipate guidelines and new industry practices will be developed over the coming month in advance of any significant works recommencing onsite. In the meantime, Watts and Hughes are preparing H&S plans to allow subcontractors to visit the site to progress the pricing of the works.

5 Watts & Hughes Methodology and Temporary Works

Watts & Hughes have completed identifying and determining the nature of the temporary works required. This includes significant vertical support to allow the removal and modification of completed works to allow the introduction of the new basement wall longitudinal steel bracing. These temporary works are necessary to allow hydro excavation of portions of the concrete basement wall which is currently supporting the structure above.

Access within the building will require temporary propping of the ramps to allow material delivery and handling of heavy components. In addition handling of some 300 tons of reinforcing steel required to form the basement slab overlay will be delivered down the ramps using a steered dolly system towed behind a vehicle. This allows long lengths of reinforcement to be negotiated around the north and south corners of the basement car park.

Due to the tight tolerances required of the Inerd bracing system discussions with Watts & Hughes steelwork subcontractor (Jensen Steel Fabricators) have identified concerns in being able to achieve the required modifications working onsite. For this reason, it is considered desirable and more cost effective where the building has not had

frustrated at the ongoing change in details being produced. Currently we are issuing updated details to Watts and Hughes for information only. Formal instruction to price the documents will follow but only once a peer review acceptance has been received.

- Significant portions of the works are difficult to price as scope and time required to undertake the works can not be easily determined. Onsite conditions could impact significantly on productivity and therefore cost risk. Sub-Contractors may not be prepared to offer a lump sum without adding price contingency which will lead to an elevated price.
- Covid-19 has impacted on the ability for Watts and Hughes to have subcontractors visit site to establish scope and methodology for the works. It is anticipated that we will revert back to Level 3 within the next 1-2 weeks with construction sites opening. This will assist Watts & Hughes being able to progress meaningful dialog with subcontractors to prepare trade pricing.

It is anticipated that the key structural steelwork component of the price will take 3 weeks to price once design is completed and accepted by Aurecon. Currently it is not clear when the Peer Review and design will be completed.

With the available information, cost estimating of the H&G steel strengthening option has been progressed by both Rider Levett Bucknall and Cuseko. The purpose of gaining a check price is to provide a level of comfort should it be necessary to make informed decisions in advance of a price being available from Watts & Hughes.

The process for developing parallel estimates has involved detailed combined briefing by TSA to provide background and insight onto the complexity of the works required. In addition, as further clarification of design detail has been issued by H&G this information has been provided to both parties.

The estimates generated have been reviewed by TSA and additions / adjustments made where necessary to ensure a final apples with apples comparison was achieved. The end result being a comparable current estimate of total project cost to undertake the H&G strengthening solution of \$53.4m.

This is broken down in general terms as follows:

• Current Contract Value (Original + Variation)	\$26.4m
• Additional strengthening and associated cost	\$16.2m
• Construction Contingency @30% of the strengthening cost	\$5.0m
• Associated costs (Fees / consents/ internal costs etc)	\$5.4m
• Costs though to commitment to proceed	\$.4m
• Total Estimated Project Cost	<u>\$53.4m</u>

It should be noted that there remain some key structural elements being challenged by Aurecon which we anticipate will result in further increase to the value identified above. This is consistent with updated design which has been received within the last 48hrs and provided for within this overall figure.

In addition the cost estimates do not take into account any reduced productivity or additional costs which will occur once the Covid- 19 isolation levels is reduced to level 3 or lower.

Cost comparison with other Options being considered are covered in section 8 of this report.

8 Option Studies

8.1 Option Descriptions

3 Options in addition to that for the current strengthening of the building have been prepared to assist with decision making. These are:

- i. Option A – Current strengthening proposal (550 parks provided)
- ii. Option B – Demolition and demobilisation leaving the basement with temporary propping to the retaining walls
- iii. Option C – Demolition and rebuild of the existing carpark design but utilising a conventional steel frame and bracing system (550 parks provided)
- iv. Option D – Progressing with the strengthening design but with 4 floors removed from the building. (278 Parks provided)

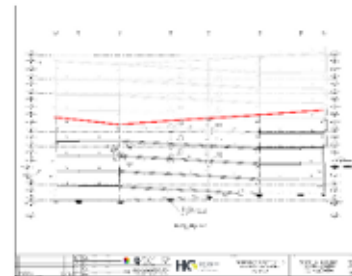

To provide a reasonable level of confidence Cuesko have provided comparison estimates for the structural steel strengthening, demolition and carpark rebuild options. It should be noted that Option D has the least confidence level in relation to cost as more detailed analysis will be required. We have based the current understanding of this option on the broad brush review and advice provided by Holmes Group.

In addition to the Options identified above Holmes Group have considered alternative conventional bracing schemes to the Inerd ductile system. Three longitudinal schemes were considered with a preferred selected which utilises insitu concrete shear walls. Initial estimates indicate that there is not a significant saving however we would recommend that if the project remains feasible at the current \$53.4m dollar figure then a shear wall option could provide greater level of confidence in the final structural form and provide savings in overall time to construct. In addition Watts and Hughes are more likely to provide a fixed lump sum on this component of the work compared to the steel strengthening of gussets, changes to bolting groups and replacement of the Inerd pins. To progress this further we would suggest that TSA consult with Watts and Hughes to validate the construction viability of the concept scheme. Following this it will be necessary to engage Harrison & Grierson to undertake modelling to establish how the stiffer structure and resulting increased loads can be accommodated. This work by H&G should not divert their efforts from completing the Option A base design to the satisfaction of the Peer Reviewer. Once design work is initiated we would anticipate further input will be required from Holmes Group to assist and give guidance.

8.2 Option Cost Estimates

For comparison, the estimated project costs for the 4 Scheme Options are as follows:

<u>SCHEME OPTION</u>		<u>RLB</u>	<u>Cuesko</u>	<u>W&H</u>			
		Cost Expended To Date \$19.1 m					
	<u>Nos of Carparks Provided</u>	<u>Total Cost</u>	<u>Total Cost</u>	<u>Total Cost</u>	<u>Adopted Estimate</u>	<u>Cost to Complete</u>	
Option A- Current Scheme	550	\$53.4m	\$53.4m	\$49.7m	\$53.4m +/- 10% On Total Construction Cost to complete	\$34.3m	

Option B – Demolish and leave Basement	0	\$23.5m	\$24.8m		<u>\$24.1m</u> +/- 10% On Total Construction Cost to complete	\$5.0m
Option C – Demolish and Re-build Conventional Car Park	550	\$54.7m	\$69.6m		<u>\$62.1</u> +/-10% On Total Construction Cost	\$43.0m
Option D -Reduced Height Option	278	\$47.6m	NA		<u>\$47.6</u> +/- 10% On Total Construction Cost to complete	\$28.5m

The level of accuracy at +/- 10% reflects that within each estimate there are contingencies which reflect the extent and level of information available to establish the overall construction estimates.

8.3 [Redacted]

[Redacted]

8.4 Options – Programme comparison

The anticipated construction programmes anticipated for each option are provided on the following page.

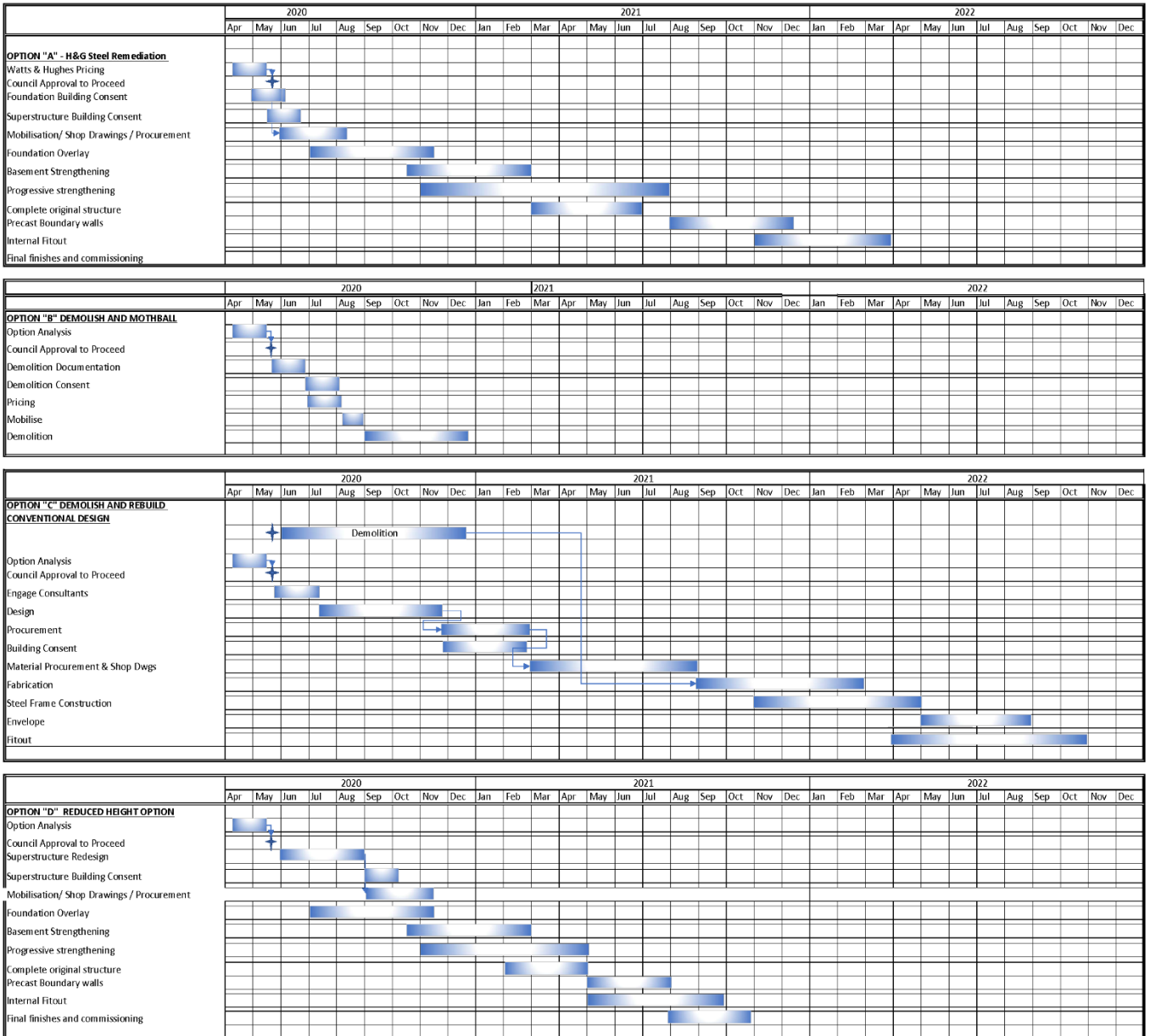

9 GENERAL ITEMS

- Since the last formal PAB meeting the Covid-pandemic and subsequent Government directive to implement Level 4 isolation measures has impacted the project in terms of accessing the site and the necessity to progress what activities are possible from individuals homes.
- The site was made secure as of the 25th March
- [REDACTED]
- [REDACTED]
- [REDACTED]

[Redacted text block]

- Planning for post Level 4 and the ability to open construction sites under Level 3 is underway. With the current level of activity onsite this is not anticipated to be too onerous and time is available to implement appropriate activities and procedures prior to a large workforce returning. It should be noted that should there be a new standard or regulation covering working within the Covid -19 environment costs associated with this, including a reduction in productivity is likely to be handled as a variation under the contract with associated time and costs awarded to Watts & Hughes.

Harington Street Transport Hub Project
WATTS AND HUGHES REPORT
Brief Overview and Synopsis of Events



4th May 2020 – Revision 1

TSA Report

Background

The Harington Street Transport Hub Project was a fully detailed design project and was granted building consent on 16th July 2018. Earthworks construction commenced on site June 2018 with a earthworks consent.

During construction it was noted a beam had reacted poorly after receiving a construction load (concrete pour) and the design engineers Harrison and Grierson were notified Friday 29th March 2019. On the 8th April 2019 HG CAN 126 was issued from Harrison and Grierson stating no compromise to its strength (beam) in the permanent position.

The 6th May WH received HG CAN139 and EI 293 instructing to prop Grid lines 1, 4.1, 4.2 and 7.

Revised seismic details were issued 7th June 2019 under EI 323 after receiving a Building Consent Amendment on 5th June 2019. These were updated 17th June 2019 under EI 338 and it became apparent the building had greater design issues that just beams reacting poorly under construction loads.

WH was instructed on 24th September 2019 under EI 416 instructing to halt all works on site.

The latest seismic detail drawings were issued 17th February 2020 and are still being reviewed.

1. Construction Overview

The proposed remedial design challenges are numerous and logistically perplexing. WH have devised a methodology based on a philosophical design of the work being able to be achieved cost effectively for Tauranga City Council.

We were first issued seismic details 7th June 2019 under EI 323. These were updated 17th June 2019 under EI 338. The latest drawings were issued 17th February 2020, and they are still being revisited.

There are significant changes continually being reviewed and introduced. As of the 1st May 2020 we do not see a competent and complete design.

Challenges we face include welding in connections behind plates that are not accessible and requiring deconstruction to construct. The coloured plating on the details adjacent are areas requiring remedial works, this occurs in numerous locations.

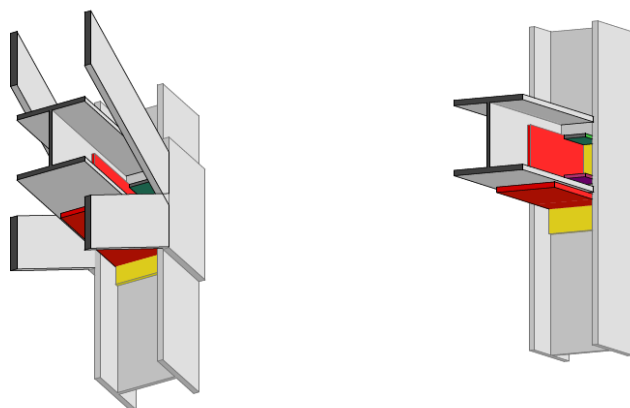

As the design is incomplete, we cannot provide certainty around achieving and completing the work successfully that is both best for the client and project in terms of durability, quality and cost effective.

The proposed design changes can be broken down into two parts, Foundations/Basement and Superstructure.

2. Foundations/Basement

An additional 350mm thick concrete overlay floor is required to provide additional strengthening to effectively spread vertical, gravity and lateral loads. The floor alone comprises of 300 tonnes of reinforcing and nearly 750m³ (140-150 truckloads) of concrete to be delivered two and half stories underground. Challenges are scanning the floor and walls of existing steel to imbed over 3000 reinforcing bars to miss the existing steel. This is time consuming and labour intensive. We anticipate a considerable amount of steel strike after previous trial tests indicated a 40% steel strike rate. Holes will need to be relocated and re-drilled.

The photo below details the volume of reinforcing steel in the existing slab that requires to be avoided for the remedial works.



The task of tying the reinforcing matt, which comprises of 4 layers of steel running in a transverse and longitudinal direction, and stirrups or shear links tied at 150mm centres in both directions. Physically support an estimated 60 tonne of upper steel placed at 250mm centres and tie 42,000 links at 150mm centres whilst constructing the raft is not an easy task.

As detailed in the adjacent sketch, basement wall strengthening to all four corners. Remedial works require hydro demolition to 8 columns. Substantial removal of fixture's and structural steel elements to allow access to the work face. A temporary works engineer must design a plan to hold and support a 20m structure, partially erected above the ground whilst the works take place.

As detailed in at adjacent sketch, additional beams are required to the 2 grids in each corner of the building including additional wall plating. The darker grey area to the top of the column is the area requiring hydro demolition while retaining stability of the existing structure.

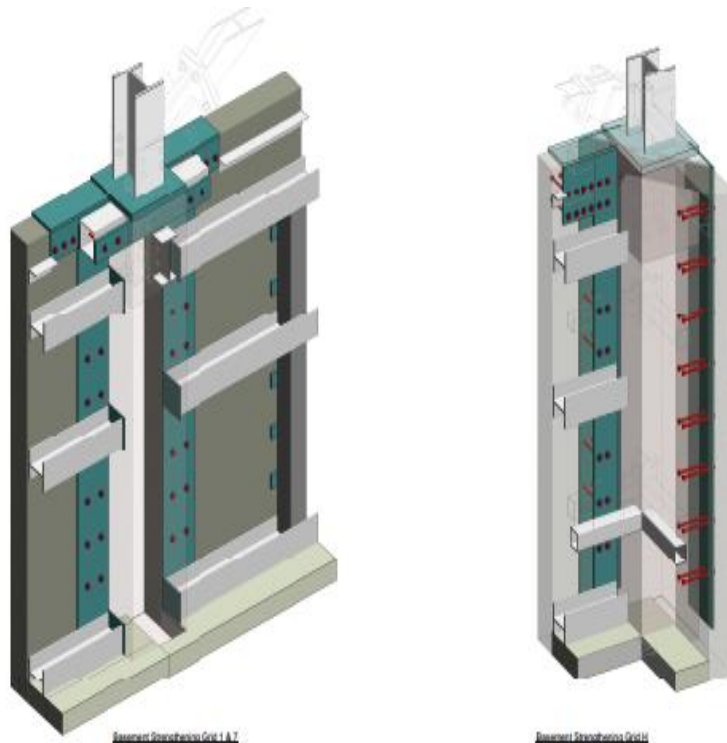

Removing and replacing a ramp that is tied to the basement floor requires considerable demolition and planning to complete safely.

Both basement wall strengthening, ramp removal and replacement see large steel beams and columns being removed and re-fitted. This brings complexity to installation as we are limited to allowable weights imposed to the existing suspended floors. Propping can mitigate the risk and allow for greater weights but will increase costs.

The waterproofing of fixings through the exterior precast walls poses risk and no guarantee has been given or obtained for these works based on the design.

One of the biggest risks we see is with basement wall strengthening and the ability to mitigate excessive noise levels generated from these works. The columns must have the top sections demolished by hydro demolition. The hydro demolition works can generate up to 95-100 dBA noise levels and we are currently restricted to working the within the allowable noise limits as set out in NZS 6803:199 Acoustics-Construction which allows up to 75 dBA. WH have sought advice from an acoustic designer who has explained in real terms the difficulty of being able to reduce the noise levels. The works are located on boundaries to neighbouring apartments offering no more than a 2m separation.

We can measure this risk early by carrying out on-site testing to conclude if this risk can be managed / eliminated.

3. Superstructure

The superstructure requires significant works to iNerd Braces, Beams, Columns etc.

Painting and protection of composite beams is a large scoped item. The structural steel component equates to 988 tonne and we currently have 694 tonne erected on site.

All structural steel excluding final coated steel will need to be surfaced, primed and made good to receive coatings. Risk is gaining safe access to steel that is elevated and work within allowable noise restrictions.

Dulux have provided a remedial scope specification for the strengthening works and have advised the steel must be profiled prior to further coatings being applied. This will involve abrasive or sandblasting to areas that will require welding and painting. This is a significant volume of work but greatest risk will be reducing the anticipated 120 dBA generated from the activity in areas which are difficult to access.

iNerd pins and connecting plates need to be removed from site as allowable tolerances will not allow this work to be done on site and will need to be done in a factory situation. The removal of these elements will be challenging due to their location on site. Some will require concrete demolition to the floor around the column. No design has been received to reinstate the floor after numerous requests by WH and TSA.

As you can see from the photo below, the square pins are specific to each iNerd Brace and reinforces the need to adjust off site for safety and accuracy of the design principles.



Top flanges of all composite beams have a durability issue. Over 8000 traydec voids have to be sealed on site that will require prep and coating.

Diaphragm bracing. No confirmed design received and is therefore hard for WH to comment.

Seismic Joints vary on site and no final solution of design has been received. Numerous columns require additional plating which requires 8 passes with a welder every 1m of column. We estimate approx. 100m of columns to be adjusted. Additional columns and beams need to be installed around the seismic joints. No complete design has been received.

Column strengthening. Beam/Beam and Beam/Column connection strengthening requires extensive plating and connection work. Access to connections to complete works may require demolition and removal of structure from site. This design is still ongoing and not complete. This will require abrasive blasting.

Stairs strengthening supports required but no final design provided.

Additional roof bracing can be done cost effective as this works has not commenced yet and will be conventional building of this scale. Floor diaphragms designs are not yet issued.

Part of the design solution sees the need for abrasive blasting, hydro demolition and these two phases of works will create excessive noise levels that may not be able to be arrested and meet the Certificate of Compliance of allowable noise limits.

An acoustic engineer has been approached and advice sought but the reply was with trepidation due to the variance between allowable and no allowable limitations. Until specifically designed shrouds fitted with ventilation, lighting that allow these to be relocated from workface to workface have actually been tested we will not know if these will meet the required standards to allow the works.

We have very serious concerns of the competency of design and meeting allowable noise levels being generated from refurbishing structural steelwork. We know these works will be costly to remediate and if excessive noise levels cannot be reduced we are vulnerable to being shut down. To negate this risk the alternative is to dismantle and refurbish the works off site but this is time versus cost.

4. Impact on neighbours

The current proposed remedial design is complex and the duration of the build will be increased due to the design of the works. Accelerated construction could see reduced time frames but ultimately results in increased costs.

Hydro demolition which is expected to take 8 days in total and it itself will be noticeable by generating up to 100 dBA.

Abrasive blasting will be ongoing for some time whilst the remedial works continue. This generates up to 120 dBA.

WH will make every effort possible to limit unnecessary noise generated from the remedial works and minimise any impact derived from the works.

Noise blankets, purposely built shrouds to contain works, acoustic designers, noise monitoring are all means which WH would employ to minimise the anticipated noise levels which the works would generate. However it is anticipated that the allowable noise limits will be frequently exceeded so brings the risk of being shut down and adding time to the programme.

We recommend consultation with all stakeholders and neighbours to discuss the issue of the potential to exceed allowable noise limits.

Air borne contaminants and dust could be an issue. Appropriate mitigation controls will be used to prevent any nuisance or negative impact to neighbours.

5. End result/Visual Impact

Additional plating, cleats, basement strengthening and plating for the Ingal Barrier system will be noticeable. The largely unknown visual impact will be with the diaphragm brace system or carbon fibre wrap. This design is not complete so cannot offer comment if this design is to go ahead but would have concerns in appearance.

6. Ability to gain fixed prices from Sub contractors.

The difficulty of obtaining fixed prices from contractors largely derives from an incomplete design. We won't mention how long it has taken but some design aspects are questionable around buildability. Incomplete design some areas are questionable if it can be done but this undermines confidence in contractors.

No one single contractor wants to price work and lose money because of the unknowns.

If a complete competent design is presented all contractors will submit fixed prices but until then we cannot find anyone willing to do so. If they do the risk will be evaluated and the job will be priced accordingly.

Covid 19: The last 5 weeks have seen a lock down over the country where no one has been able to work. This includes the ability to go to site and evaluate scopes of works.

Summary:

WH are here to help Tauranga City Council to resolve the current engineering challenges that the project faces. WH have a resource and depth of contractors that can perform and execute the remedial works proposed. After consultation undertaken with all our relevant sub contractors it has been deemed the seismic detail drawings have high costs associated to them and encompasses significant risk. Consideration must be given to evaluate if cost and risk will outweigh the solution.

To reinforce, WH are committed to the project and can construct any works but we want the best value for money for our Council and City and reviewing all details from cost, programme and aesthetics.

Project Name: Harington Street Transport Hub
To: Nick Johansson / James Woodward (TCC)
Prepared by: Malcolm Sabourin TSA
Subject: Status Update Report Report
Report Period: To: Saturday 9th May 2020

1.0 OVERVIEW

The current emphasis is to be able to report back to the PAB on the following primary areas of focus:

- Resolution of outstanding H&G design issues which are needed for Aurecon to complete the Peer Review. TSA continue to apply pressure on H&G with the aim of receiving timely responses to requests for clarification generated by Aurecon and Watts and Hughes.
- Watts & Hughes Pricing of the works – This is being held until Harrison & Grierson can provide substantially completed design documentation which has been reviewed and approved by the Peer Reviewer..
- Costings for the following Options have been completed, They have recently been revised

Options include:

- Option A - Design as documented
- Option B - Demolition to leave a basement ready for future development of the site
- Option C - Demolition and rebuild of carpark using a conventional structure
- Option D - Reduction by 4 floors

Programme

We reported at the last PAB meeting that based on advice from Harrison & Grierson that design would substantially be completed within 2-3 weeks. This follows acceptance by Aurecon on the analysis approach for the diaphragm and other key components of the structure. Since the meeting on the 23rd April there has been limited progress to get this design underway. Once received, and provided the design is adequate, there is a period of 4-5 weeks to conclude subcontract pricing and for Watts and Hughes to submit an overall price for consideration. .

2.0 DESIGN

Building Superstructure

It was anticipated that H&G would have substantially demonstrated the adequacy of their design solution addressing key areas of concern over the last 2 weeks. This has not occurred and despite regular meetings with Aurecon they are struggling to reach a point where design analysis and calculations can be provided for review. The key areas of concern are currently:

-
- Diaphragm Performance. H&G have yet to demonstrate to Aurecon that their approach to the analysis of the diaphragm is acceptable. This is impacting progress . Once the loads have been determined it will then be necessary for H&G to consult with a specialist supplier to prove that the carbon fibre overlay can provide the required strength and perimeter transfer of load into the structural frame is possible. It is only once there has been engagement with the supplier that we can be confident the proposed remedial works will be accepted by Aurecon. Currently there is inadequate information to engage with the carbon fibre specialist.
 - Basement Bracing Solution - H&G have yet to respond to Aurecon's request for the designer to review the manner in which significant loads are transferred from the superstructure into the basement walls. This issue was identified mid April and has not been responded to.

These are two areas where TSA are concerned that the slow resolution of a design solution suggests the issues are significant and as such Harrison & Grierson are struggling to demonstrate a remedial works solution.

Although the focus remains on the diaphragm and basement bracing there remain a significant number of more minor issues and details to be resolved to allow conclusion of the superstructure Peer Review and a consenting package to be completed. Timing for resolution of design has not been forthcoming from H&G with key dates not being achieved resulting in ongoing slippage.

Independent Design Review- Shear Wall Alternative Design Solution

A small amount of work was undertaken by Holmes Group to complete their investigation of an alternative bracing design solution using more conventional design. This has identified challenges which will require significant foundations to the perimeter walls in the lowest basement level. In addition there is likely to be a transverse wall required to transfer load. Both of these impact the use of this lower level and currently indicate that a significant number of parks on this level would be lost.

The option of using more conventional bracing as a design solution is not being pursued further until the commercial viability of the carpark strengthening is proven.

3.0

BUILDING CONSENTS

Foundations:

The revised design for the foundations has been received with the PS1 and PS2. This is ready for submission to Council. We are currently holding off on submitting the revised consent documentation until the current project review has been completed

Building Superstructure Peer Review

With little progress being made in the last period it is difficult to identify timing for the Superstructure Peer Review to be concluded due to H&G delivery dates not being achieved and the programme continuing to slide.

As we have identified earlier we appear to remain in a state where elements of the structural strengthening are still in a design phase and have not been resolved to the Peer Reviewers satisfaction.

4.0 WATTS & HUGHES

Pricing of the Works

With Covid Level 3 now in place this provides an opportunity for Watts and Hughes to progress meaningful engagement with their suppliers and subcontractors. The key subcontractor being Jensens who will price the Steelwork modifications. To undertake this pricing the completed H&G design is required.

Until the H&G design is completed and until the high-level feasibility and Project review is completed we are holding off encouraging further dialog between Watts & Hughes and Jensens. As such it is not possible to progress the pricing of the works.

Watts & Hughes Reporting

Watts & Hughes have previously provided a methodology report which describes the manner in which the works are to be carried out. This has been used to inform our quantity surveyors in the preparation of estimates. More recently Watts & Hughes have prepared a further report which outlines the challenges which these works present. This is intended to inform Council of some of the key issues and an appreciation of the activities which can be expected moving forward.

The key elements of this report being:

1. The ability to control noise levels at the adjacent boundaries with separation being no more than 2m in places. For this reason it is suggested that where possible existing steelworks be removed and the preparation for painting be undertaken offsite. This would reduce the impact on the adjacent neighbours. Where this is not possible extensive acoustic screening will be required however there is concern that this will not achieve the required maximum allowable noise levels. Agreement is likely to be required with neighbours for noise levels to be exceeded for periods of time to allow the works to proceed.
2. Complexities of beam / column remedial works which challenge contractors on the practicalities of undertaking the works
3. Challenges relating to the installation of dowel bars into the existing foundations to achieve the overlay. It is anticipated that there will be a high number of locations that will be abandoned during the drilling process due to conflict with existing reinforcement and the dowel needing to be relocated.
4. Removal of INerd pins to allow works to be undertaken in controlled conditions
5. Achieving the necessary level of quality where the top of existing beams are to be painted to address exposed steelwork and avoid future corrosion issues

The Watts & Hughes report provides Council and the technical consultants a better appreciation of what is required to undertake the works and associated areas of risk.

Site Security / Health and Safety

- The site continues to be under the control of Watts & Hughes with no incidents reported during the Covid 19 level 4 lockdown period.
- There have been no Health and Safety incidents over the last reporting period
- The site currently is operating under revised H&S processes to reflect the Covid 19 threat. As there is no construction activity currently underway these measures are not onerous and distancing is relatively easily achieved.

5.0 FINANCIAL

Financial Work Stream 1 – Watts and Hughes Pricing

- Further development of a price to undertake the works is dependant of the completion of the Harrison & Grierson structure design details and providing response to clarifications requested by Watts & Hughes.

Financial Work Stream 2– Rider Levett Bucknall Cost Estimating –

- There has been no further meaningful information produced by H&G to allow Rider Levett Bucknall to review their estimates further.

Financial Work Stream 3– Parallel Cost Estimates for Strengthening Option

This work stream undertaken by Rider Levett Bucknall and Cuseko is now complete with estimates issued on the cost for the following Options:

- Strengthening as per the H&G design
- Demolition and Rebuild using conventional design

Financial Work Stream–4 Options Studies

The following Options Studies have been prepared and presented to the PAB so that further financial modelling can be undertaken to assist in decision making:

- Option A – Current design solution
- Option B - Demolition leaving only a basement
- Option C – Demolition and rebuild carpark using a conventional structural solution.
- Option D – Reduction in height by 4 floors

During the last 2 weeks and following feedback from the PAB. TSA and Rider Levett Bucknall have undertaken a further review of Options B&C. As a result, the estimated costs of these two options have been adjusted as follows:

- a) Option 3 Demolition
 - Cost estimates adjusted to reflect additional works to leave the site in a safe condition and allow access to maintain the site

[Redacted text block]

- b) Option 4 – Demolition and Rebuild

[Redacted text block]

The amended cost estimates have therefore been adjusted as follows:

[Redacted]	[Redacted]	[Redacted]	[Redacted]
[Redacted]	[Redacted]	[Redacted]	[Redacted]
[Redacted]	[Redacted]	[Redacted]	[Redacted]
[Redacted]	[Redacted]	[Redacted]	[Redacted]
[Redacted]	[Redacted]	[Redacted]	[Redacted]
[Redacted]	[Redacted]	[Redacted]	[Redacted]
[Redacted]	[Redacted]	[Redacted]	[Redacted]
[Redacted]	[Redacted]	[Redacted]	[Redacted]

resolve the three fundamental areas of design which include:

- Pin and associated plate modifications
- Diaphragm action
- Splice and Column Joints

being sought from Jensen's to ensure that the design solution can be achieved

Steel Primer

High

There is a risk that the steel primer on the upper levels is no longer effective due to the length of time it has been exposed and will require replacement

Testing proposed to try and determine extent of the issue . An estimate of extent will need to be the basis of the W&H pricing.

Noise and Dust

High

Should replacement of the primer be required this is require sandblasting to prepare the surface. The noise levels will exceed boundary maximum levels

Watts & Hughes enlisting the advice of an acoustic engineer to advise on noise containment initiatives
Agreement maybe required with adjacent property owners to allow periods where noise levels exceed boundary controls..

Hydro excavation

High

There is a risk that the noise levels resulting from using Hydro Excavation techniques will exceed the permissible maximum boundary levels

Watts & Hughes consulting with an acoustic engineer to develop noise screening methodologies.
Agreement maybe required with adjacent properties to allow periods where noise levels exceed boundary controls.

Cost Certainty

Medium

There is a risk that either extent of works or methodologies present risk to subcontractor result in subcontractors not being willing to fix their prices

Watts & Hughes being advised that Councils expectation is that a fixed price lump sum is required to keep pressure on for an acceptable price submission.

KEY ISSUES

- Completion of H&G design of critical components to prove there is an overall viable design solution
- Completion of H&G detailing of the works required for the Peer Review and pricing of the works
- Conclusion of Council High Level Project review.

Project Name: Harington Street Transportation Hub
To: Nick Johansson / James Woodward (TCC)
Prepared by: Malcolm Sabourin TSA
Subject: **Aurecon Status Report**
Report Period: To: Sunday 10th May 2020

1.0 OVERVIEW

Further to TSA Status report through to the 9th May 2020 we have received correspondence from Aurecon which provides advice on”

- The status for design review. The comments are generally aligned with advice within the TSA report.
- Commentary on potential areas of ongoing inspection and maintenance. This relates to the risk of corrosion should moisture build up occur within the added strengthening components over time.

Aurecon are engaged to undertake a peer review of the Harrison & Grierson Harington Street Transportation Hub structural remediation works.
TSA have asked Aurecon to comment of the wider implications of the design solution developed to date.

We have highlighted key items below and included (In Red) TSA comments where applicable

2.0

1. Design Progress;

- Minor amendment to foundation submission made, reviewed and PS2 issued by Aurecon in response to RFI from TCC
- Methodologies in respect of diaphragm designs proposed by HG and reviewed by Aurecon, **ongoing discussions/amendments**...see below
- Several updates of time history analysis of the structure completed and submitted by Compusoft/HG together with report, outputs reviewed and commented on by Aurecon
- Column strengthening designs submitted by HG, under ongoing review by Aurecon
- Column splice designs submitted by HG, reviewed and commented on by Aurecon...see below
- Details of basement wall connections to Grid 1&7 braces submitted by HG, reviewed and commented on by Aurecon...see below
- Review of capacities of plates to INERD pin connections submitted by HG, reviewed and commented on by Aurecon
- Barrier designs reviewed by Aurecon, confirmation that architects drawings correctly show layout only outstanding issue.

FYI HG/Compusoft and Aurecon have been holding regular meetings (3-5 times a week) to discuss outstanding issues.

Key areas still to be finalised are;

- Floor Diaphragms. The demands resulting from applying the diaphragm provisions of the loading code NZS1170.5 (based on the overstrength of the bracing structure) **are proving to be onerous**. Aurecon have had ongoing discussions with HG on alternative modelling approaches that they could consider. HG have been rerunning analyses to review the results of these. The demands impacts on diaphragm strengthening requirements including detailing improvements to collector beams framing into the braces. May also impact on column strengthening requirements as columns provide some of the lateral bracing between floors. **Still work in progress.**
 - Grid 1&7 Brace Connections to Basement Walls . HG have presented several updated proposed tie down details at the corner INERD frames which has been reviewed by Aurecon and discussed with them. HG have been requested to demonstrate the load paths and ensure fixity effects are properly considered (not currently allowed for in the modelling or design). Noding eccentricities at bolt connections of INERD brace connection to columns/ base plates also to be considered. **Still work in progress.**
 - INERD pin sizing. **A potential issue with the distribution of cumulative floor brace capacity** (grids 1 and 7) over the building height. At one level the brace capacity in the longitudinal direction is less than the level above, and while the time history analyses is able to demonstrate the adequacy of the bracing working in conjunction with the columns, **we don't believe it is good practice**, and probably impacts on the diaphragm demands and column strengthening requirements at the level in question. Solution is to upgrade the pins to these 4 braced bays. A significant jump in brace capacity to the lower level 2-1 (compared with level above) also occurs which is driving the diaphragm demands and our recommendation has been to reduce the pin capacities over this level. HG are reviewing.
 - Final details and calculations for the proposed upgraded/ modified pin connections **still to be received.**
 - Column splice details at change in column section size being reconsidered by HG following concerns raised by Aurecon regarding current constructed detail.
 - Quality of the structural steel plate to the INERD brace connections to be reviewed. Confirmation of the Z values of the thick plates in respect to suitability for butt welding of thick plates to one another without potential lamellar tearing issues.
TSA Comment – We understand that plates will need to be selected from the completed steelwork components and tested to prove adequacy prior to Aurecon providing a PS2.
 - Confirmation of the capacity and stability of the pin connection plates to the INERD braces under compression and bending.
 - Amended detailing of the stair connections to the structure for the stairs to accommodate inter-storey drifts.
 - Drawings of the superstructure that reflect the final design.
-

-
- Confirmation from Compusoft that the final design/documentation from HG reflects the analyses assumptions and parameters adopted in their analyses.
 - Secondary issues to be reviewed (once primary issues resolved) include detailing of the exterior cladding to accommodate interstorey drifts, detailing of cover plates across ramp movement joints, detailing of the façade at junction of ramp movement joints (mj to be reflected up the height of the building).
-

2. Key Show Stoppers:

- Grid 1 and 7 brace connections to basement walls
- Floor diaphragm strengthening and upgrade of collector connections to braces
- Quality of the structural steel plate to the INERD brace connections. Any identified short comings will require existing plates/ connections to be replaced.

TSA Comment – The items identified by Aurecon are consistent with our view that without resolution of these show stoppers we do not have a design solution which can be taken forward.

3. Maintenance Challenges;

- Corrosion protection to steelwork will be the key maintenance challenge going forward, driven by an exposed steel structure in a coastal environment. Some of the structural elements are already exhibiting corrosion, notably along edges of beams, columns and plate elements that are only incorporate the primer paint coat.

Corrosion protection of the INERD pins is an important issue. Where the INERD pins pass through the cleat plates to the brace connections the junctions between the pins and plates need to be appropriately sealed to prevent moisture ingress that may eventually lead to corrosion of the pins or plate edges and impact on the structural integrity of these elements in particular. We are unsure but presume that no paint system or possibly only a primer has been applied to the pins to date. Any sealant will need to accommodate some nominal movement between the pins and the plates.

It will also be necessary to ensure all interfaces between new plating to existing columns, beams etc installed under the seismic upgrade works are appropriately sealed to preclude moisture ingress and future corrosion between interfaces.

TSA Comment – Increased supervision will be required through the construction phase to prove quality assurance processes are effective. In addition, an ongoing inspection and maintenance scheme will be required to identify and address any signs of corrosion in and around the plating and complex beam / columns junctions.

Project Name: Harington Street Transport Hub
To: Nick Johansson / James Woodward (TCC)
Prepared by: Malcolm Sabourin TSA
Subject: Status Update Report Report
Report Period: To: Sunday 17th May 2020

1.0 OVERVIEW

This update report is intended to inform Council and the PAB of changes in status of technical workstreams following the PAB meeting on the 23rd April 2020 and the subsequent briefing of Executive briefing held on Monday 11th May 2020. We have only focused on the changes during the period to allow the PAB to advise and endorse the upcoming report to Council,

Design

The Harrison & Grierson strengthening design continues to be challenged by the Peer Reviewer (Aurecon). The floor diaphragm and mechanism for transfer of loads from basement strengthening to the adjacent structure being two key areas for which a satisfactory solution has not currently been demonstrated.

The scope of works continues to increase as the structural model is analysed and elements are identified as lacking in the necessary strength to comply with relevant structural codes.

Option Studies

Of the 4 Option Studies the scope of Demolition and Demolition and Rebuild has been reviewed since the last PAB meeting. [REDACTED]

[REDACTED] In addition the scope of Demolition has been adjusted to account for works required to leave the site in a safe condition.

Cost Estimates

Previous discussions have identified concerns that the estimate for Option A (H&G Strengthening) is likely to increase. Since the last report additional scope has added \$2m to the RLB estimate. As of writing this report and based on the information currently available the cost of the Strengthening Option now stands at \$55.4m. This value includes a design development contingency which covers changes to known design elements but not any additional items which are introduced. We have therefore amended the accuracy of the overall cost estimate from plus/ minus 10% to plus 15%/minus 0% . This makes allowance for anticipated further increases in scope to cover design elements which are anticipated to resolve the diaphragm and basement load transfer solutions. As of writing this report that cost estimates for each of the options are as follows:

- Option A – Current design solution \$55.4m
- Option B - Demolition leaving only a basement \$26.2m
- Option C –Demolition and rebuild carpark using a conventional structural solution \$63.7m
- Option D –Reduction in height by 4 floors \$47.6m

Buildability.

Watts & Hughes have further developed strategies for controlling noise levels generated by both sandblasting of steelwork and hydro excavation of concrete within localised areas of the basement walls. They have confirmed that this will be possible albeit with a cost premium to build acoustic walls around the work areas. This was a significant concern which can now be considered as closed.

Programme

Due to the incomplete design documentation it has not been possible for Watts & Hughes to engage with their steelwork subcontractor to develop a price for the works. There is a reluctance to price works which continue to change in detail resulting in abortive efforts. For this reason we are waiting to reach a point where the Peer Reviewer is satisfied with the solutions before distributing documentation.

Once design is substantially complete there will be a 4-5 week period during which pricing can be undertaken in parallel with a superstructure building consent package being submitted for processing.

As of writing this report Harrison & Grierson are unable to advise when they can have their design ready for a completion milestone.

2.0

DESIGN

Building Superstructure

Key Areas of Design

There continues to be ongoing dialog between Aurecon and Harrison and Grierson aimed at the designer proving that their solution is compliant with code. Once resolved to Aurecon's satisfaction a PS2 will be provided which is required to obtain a Building Consent for the works.

The design adequacy of the floor diaphragm and the transfer of loads from the basement strengthening components into the adjacent structure remain two key areas which have not been resolved since our last report. Based on comments generated by Aurecon there are elements which are not detailed within the design documents which adequately demonstrate the full scope of works required. Hence, we anticipate as these works are defined there will be a further upward movement in price.

Increased Scope

The structural model continues to be run as each design component is refined. As a result, there has been further increase in the scope to the strengthening works which has been identified in correspondence between H&G and Aurecon. These items include:

- Additional column / beam connection strengthening in the lower levels
- Increased number of Inerd Pin connections which need to be modified. Where possible these will be removed from the site and works undertaken within the steel fabricators yard to achieve the required tight tolerances.

The cost of these elements has been estimated and included with the current cost update.

As previously noted in TSA reports, we are progressively redesigning elements of the building as issues are identified and inadequacies brought to the fore. The extent of redesign is not commonly experienced to this extent in a peer review process.

3.0 WATTS & HUGHES

Pricing of the Works

With Covid Level 2 now in place this provides an opportunity for Watts and Hughes to progress meaningful engagement with their suppliers and subcontractors. The key subcontractor being Jensens who will price the Steelwork modifications. To undertake this pricing the completed H&G design is required as there is a reluctance to commit resource when design details and scope continue to change.

Until the H&G design is completed and accepted by Aurecon we are holding off distributing further documents. Watts and Hughes however are continuing to engage with supplies and advisors to refine their methodologies in areas where the Covid 19 level 4 restrictions prevented meaningful dialog. The key area being acoustic control at the site boundaries as a result of the use of sandblasting and hydro- excavation equipment. The current planning involves acoustic barriers constructed around the work elements which would allow the noisy works to be completed and then allow the barrier to be relocated to other areas

Site Security / Health and Safety

- The site continues to be under the control of Watts & Hughes with no incidents reported during the last period
- The site currently is operating under revised H&S processes to reflect the Covid 19 threat. As there is no construction activity currently underway these measures are not onerous, and distancing is relatively easily achieved.

4.0 FINANCIAL

Financial Work Stream 1 – Watts and Hughes Pricing

- Further development of a price to undertake the works is dependant of the completion of the Harrison & Grierson structure design details and providing response to clarifications requested by Watts & Hughes.

Financial Work Stream 3– Parallel Cost Estimates for Strengthening Option

- There has been no further need to engage with Cuesko during the latest reporting period.

Financial Work Stream–4 Options Studies

The following Options Studies have been prepared and presented to the PAB so that further financial modelling can be undertaken to assist in decision making:

- Option A – Current design solution
- Option B - Demolition leaving only a basement
- Option C – Demolition and rebuild carpark using a conventional structural solution.
- Option D – Reduction in height by 4 floors

During the last 2 weeks and following feedback from the PAB. TSA and Rider Levett Bucknall have undertaken a further review of Options A,B&C. As a result, the estimated costs of these three options have been adjusted as follows:

- a) Option A Structural Strengthening.
-



RISKS -New Risks Identified in Bold

Emerging Key Risks	Risk	Rating	Mitigation
	<u>Achieving Design Solution</u> There is a risk that there is not a practical and economical solution to resolve the three fundamental areas of design which include: <ul style="list-style-type: none"> • Pin and associated plate modifications • Diaphragm action • Splice and Column Joints 	High	H&G are responding to Aurecon RFI's challenging the design. Buildability advice is being sought from Jensen's to ensure that the design solution can be achieved Cost estimates have been prepared with a parallel exercise undertaken by Cuesko. Pricing by Watts & Hughes will be undertaken once design I accepted by Arecon.
	<u>Steel Primer</u> There is a risk that the steel primer on the upper levels is no longer effective due to the length of time it has been exposed and will require replacement	High	Testing proposed to try and determine extent of the issue . An estimate of extent will need to be the basis of the W&H pricing.
	<u>Noise and Dust</u> Should replacement of the primer be required this is require sandblasting to prepare the surface. The noise levels will exceed boundary maximum levels	High	Watts & Hughes enlisting the advice of an acoustic engineer to advise on noise containment initiatives Agreement maybe required with adjacent property owners to allow periods where noise levels exceed boundary controls. Currently noise barriers have been allowed to control noise levels albeit at a cost premium.
	<u>Hydro excavation</u> There is a risk that the noise levels resulting from using Hydro Excavation techniques will exceed the permissible maximum boundary levels	High	Watts & Hughes have consulted with an acoustic engineer to develop noise screening methodologies. Agreement maybe required with adjacent properties to allow periods where noise levels exceed boundary controls.
	<u>Cost Certainty</u> There is a risk that either extent of works or methodologies present risk to subcontractor result in subcontractors not being willing to fix their prices	High	Watts & Hughes being advised that Councils expectation is that a fixed price lump sum is required to keep pressure on for an acceptable price submission.

Quality

Med

This risk is difficult to mitigate.

Added strengthening will be visible on completion of the project which may attract comment and add operating costs higher than usual.

7.0**KEY ISSUES**

- Completion of H&G design of critical components to prove there is an overall viable design solution
 - Completion of H&G detailing of the works required for the Peer Review and pricing of the works
 - Completion of H&G design which allows Watts & Hughes pricing to progress.
 - Conclusion of Council High Level Project Options review.
-



ADVISORY REPORT LAND VALUE ESTIMATE

**40 Harington Street
Central Business District
Tauranga City**

Client Tauranga City Council
Value estimate date 18 May 2020

25 May 2020

Tauranga City Council
Private Bag 12022
TAURANGA 3143

Attention: Brigid McDonald

ADVISORY REPORT

40 HARINGTON STREET, CENTRAL BUSINESS DISTRICT, TAURANGA CITY

In accordance with your specific instructions, we completed a roadside inspection of the above property on 18 May 2020 to provide a value estimate as at that date.

We have been instructed to provide an abridged report format. Due to the basis on which we have been instructed, this report and value estimate provided **does not constitute a valuation** and does not comply with the requirements of International Valuation Standards 2020 and Australia and New Zealand Valuation Guidance Notes and Technical Information Papers.

1 SCOPE OF WORK

1.1 THE VALUER

The value estimate has been undertaken by Michael Reay who provides this objective and unbiased advice. The valuer has no material connection with the instructing party or interest in the property and has the appropriate qualifications and experience to undertake the value estimate.

1.2 OUR CLIENT

Tauranga City Council.

Other than the client or addressee, the report may not be relied upon by any third party. We accept no liability to third parties. Written consent is required for any third party wishing to rely on this report. We reserve the right to withhold that consent, or to review the contents of the report if consent for third party use is sought.

1.3 PURPOSE OF ADVICE

Feasibility and decision making.

This report is indicative in nature and should not be relied upon as a basis for any contract that relies upon this indication as a statement of value for the purpose of sale or purchase of a property or as an asset value to be relied upon by any other third party.

1.4 PROPERTY ADDRESS

40 Harington Street, Central Business District, Tauranga City.

1.5 BASIS OF ESTIMATE

The value estimate provided in this report is our preliminary opinion, undertaken on a market basis. Market Value is defined in International Valuation Standards 2020 as:

The estimated amount for which an asset or liability should exchange on the valuation date between a willing buyer and a willing seller in an arm's length transaction, after proper marketing and where the parties have each acted knowledgeably, prudently and without compulsion.

The value estimate may change in the future because of market conditions and changes to the state of the property.

1.6 DATE OF VALUE ESTIMATE

Inspection date 18 May 2020

Estimate date 18 May 2020

1.7 EXTENT OF INVESTIGATIONS

Due to the basis of which we have been instructed, the level of market investigation we carry out may be less extensive than we would normally undertake in preparing a valuation.

This report has been prepared for advisory purposes only and is not a geotechnical or environmental survey. If any defect is found, including structural defects, this information could impact on the value of the property.

1.8 NATURE AND SOURCE OF INFORMATION RELIED UPON

Information used to prepare the valuation has been obtained from our property inspection and public records.

No other information or documentation of particular significance to the valuation has been relied upon without specific verification by the valuer.

1.9 ASSUMPTIONS AND SPECIAL ASSUMPTIONS

Standard valuation assumptions made in completing the report are stated in 'Extent of Investigations' and 'Statement of Limiting Conditions and Valuation Policy'.

Significant Assumptions and Special Assumptions made within the valuation are as follows:

- Our value estimate excludes all improvements (including basement) and assumes a vacant site at natural ground level.

1.10 REPORTING FORMAT

We have been instructed to report in an abbreviated format. It does not comply with the requirements of International Valuation Standards 2020 and Australia and New Zealand Valuation Guidance Notes and Technical Information Papers.

This report must be read in conjunction with TelferYoung (Tauranga) Limited's Statement of Limiting Conditions and Advisory Policy.

2 LEGAL DESCRIPTION

The property comprises a number of estates in Fee Simple, with Record of Title Identifiers issued as follows:

Identifier	Legal Description	Area
786686	Lot 1 Deposited Plan 28153 Parking Purposes	541 m ² (more or less)
SA780/237	Part Block 4 Church Mission Reserve	567 m ² (more or less)
SA27A/838	Lot 1 Deposited Plan South Auckland 29835	564 m ² (more or less)
SA25B/1193	Lot 2 Deposited Plan 2815310	591 m ² (more or less)

Despite the title area of SA780/237 being 567 m², the mapping software 'QuickMap' states the land area of this title to be 556 m². We have adopted the QuickMap area. This derives a total land area of **2,252 m²**.

All are located in the South Auckland Land Registration District.

All titles have a Section 77 Building Act Certificate that states all titles are to be sold in a single transaction. This is due to Building Consent for the carparking having been issued that extends across Title boundaries. See Appendix A for the Records of Title.

3 BRIEF PROPERTY DESCRIPTION

- This is a City Centre zoned site located at the periphery of the Tauranga CBD.
- The land has an area of 2,252 square metres, comprised within 4 Records of Title.
- It has good access via two street frontages, potential views from mid to upper levels, particularly from the southern half of the site.
- Limited retail potential.
- Easy contour.

The site is part-way through construction of a multi-level carparking building. Our valuation disregards all improvements (including basement) and assumes a vacant site.

4 BASIS OF VALUE ESTIMATE

To estimate the Market Value of the land, as per International Valuation Standard 105, we have utilised the Market Approach.

The Market Approach provides an indication of value by comparing the asset with identical or similar assets for which price information is available. In this regard, we have considered the Comparable Transactions method to value. In assessing value via this method, a unit of comparison that is used by market participants is first identified to establish valuation metrics, and then comparative analysis of qualitative and quantitative similarities and differences between the comparable sales and the subject is performed. The analysed valuation metrics are then applied to the subject establish the market value.

This approach considers the sale of other vacant land, these sales are analysed on the basis of value per square metre (\$/m²). Comparison against the subject property includes making adjustments where necessary for differences in factors such as location, size, shape, contour, zoning and where development may incur additional costs through soil or on site conditions.

5 VALUE ESTIMATE

Relevant land sales are summarised below. Full details are appended to this report.

Address	Sale date	Sale price	Land area	Land value (\$/m ²)
199 to 213 Cameron Road	24 October 2018	\$6,250,000	2192m ²	\$2,691.61
60 Harington Street	9 April 2018	\$8,025,000	2755m ²	\$2,386.57
2 Rata Street	28 March 2018	\$5,600,000	2118m ²	\$2,644.00
69 Spring Street	7 December 2017	\$6,000,000	2461m ²	\$2,520.00
124 Willow Street	1 April 2017	\$1,100,000	630m ²	\$1,746.03
93 Durham Street	14 February 2017	\$1,391,304	808m ²	\$1,721.91
71 Devonport Road	28 October 2016	\$1,900,000	835m ²	\$2,275.45
Land value range				\$1,722/m² - \$2,692/m²

We have considered a range of CBD land sales and also a relevant sale in Mount Maunganui (2 Rata Street). The sales show a range of land values between \$1,722 and \$2,692 per square metre. Most of the properties had improvements and our analysis of land values is after allowing for demolition costs, offset by holding income.

- The most relevant sale that provides the best indication of land values in and around the Tauranga CBD is the car-yard at 199-213 Cameron Road that sold in October 2018 with analysed land value of \$2,692/m². The subject's location is slightly inferior due to its peripheral position in the CBD with limited vehicular and pedestrian traffic.
- 60 Harington Street at \$2,387/m² is a motel that was priced on land value. It is located a short distance west of the subject, in a more peripheral location but on an excellent site with 4 street frontages. Analysis is after allowing for holding income, less demolition costs. This is a slightly superior site but requires positive time adjustment.
- 69 Spring Street is a prominent corner site comprised of 4 individual titles. The site is improved with a 1950s building with low seismic strength and of utilitarian design that would be problematic to modernise. We

understand that it was not feasible to use the existing structure and the property was purchased by a local developer for redevelopment. The sale price reflects \$2,438 per square metre. Alternative analysis on a redevelopment approach allowing for building demolition costs, partially offset by 2 years holding income derives a land value of \$2,520 per square metre.

In addition to the above sales, we are aware of 2 current confidential, conditional agreements for development sites in the Tauranga CBD. The proposed prices broadly fall within the expected range outlined by the above sales.

Conclusion

In our opinion, based on our limited investigations, our preliminary estimate of value for this property, effective as at 18 May 2020, is **\$5,350,000** plus GST (if any).

This is calculated as follows:

Component	Area	Rate	Total
Land			
Site area	2,252 m ²	@ \$2,250 per m ² =	\$5,067,000
		@ \$2,500 per m ² =	\$5,630,000
Total Land Value			\$5,348,500
Market Value Estimate			\$5,348,500
		Adopt	\$5,350,000

Prior to the Coronavirus pandemic, our estimate would have been at the upper end of this range.

We reiterate that, in accordance with instructions, we have provided a value estimate, which does not constitute a valuation.

Our estimate is subject in all respects to confirmation by undertaking a full inspection and investigation of the property and this may result in a material adjustment to the estimate herein provided.

If required, we would be pleased to provide a valuation, however this will require a full property inspection and investigation of market evidence to be undertaken.

6 STATEMENT OF LIMITING CONDITIONS AND ADVISORY POLICY

Purpose

This report has been completed for the specific advisory purpose stated. No responsibility is accepted in the event that this report is used for any other purpose. We do not accept liability for losses arising from reliance on our value estimate.

This report is indicative in nature and should not be relied upon as a basis for any contract that relies upon this indication as a statement of value for the purpose of sale or purchase of a property or as an asset value to be relied upon by any other third party.

Responsibility to third party

Our responsibility is limited to the client to whom the report is addressed and to that client only. We disclaim all responsibility and will accept no liability to any other party without first obtaining the written consent of TelferYoung (Tauranga) Limited and the author of the report. TelferYoung (Tauranga) Limited reserves the right to alter, amend, explain or limit any further information given to any other party.

Reproduction of report

Neither the whole nor any part of this advisory report or any reference to it may be included in any published document, circular or statement without first obtaining our written approval of the form and context in which it may appear. Our report is only valid when bearing the Valuer's signature.

Date of advice

Unless otherwise stated, the effective date of the advice is the date of the report. The advice provided is current as at the effective date only. The market may change significantly and unexpectedly over a relatively short period (including as a result of general market movements or factors specific to the particular property).

Legislation

We have not obtained a Land Information Memorandum (LIM) or Property Information Memorandum (PIM) for this property which unless otherwise stated is assumed to conform to all requirements of the Resource Management Act 1991, the New Zealand Building Code contained in the First Schedule to the Building Regulations 1992, the Building Act 1991, the Building Act 2004 and any Historic Places Trust registration. Our reports are prepared on the basis that properties comply with all relevant legislation and regulations and that there is no adverse or beneficial information recorded on the Territorial Local Authority (TLA) property file, unless otherwise stated. Legislation that may be of importance in this regard includes Health & Safety in Employment Act 1992, the Fire Safety and Evacuation of Buildings Regulation 1992, and the Disabled Persons Community Welfare Act 1975.

Registrations

Unless otherwise stated, our report is subject to there being no detrimental or beneficial registrations affecting the value of the property other than those appearing on the title. Such registrations may include Waahi Tapu and Heritage New Zealand registrations.

Reliability of data

The data and statistical information contained herein was gathered for advisory purposes from reliable, commonly utilised industry sources. Whilst we have endeavoured to ensure that the data and information is correct, in many cases, we cannot specifically verify the information at source and therefore cannot guarantee its accuracy.

Inspections

Advisory work may be undertaken without a full inspection of the property being made, where specifically instructed by a client. In such circumstances our advice has been prepared on the basis of property information provided by a client or otherwise available to us, including information we hold from a previous inspection or gained from a roadside inspection. The limited extent of our inspection may have a material impact on our value estimate and we do not accept responsibility for any assumptions made that are incorrect on account of our limited inspection.

Assumptions

This report contains assumptions believed to be fair and reasonable at the date of reporting. In the event that assumptions made based on information relied upon is later proven incorrect, or known by the recipient to be incorrect at the date of reporting, TelferYoung (Tauranga) Limited reserves the right to reconsider the report and advice provided.

GST

The available sources of sales data upon which our value estimate is based generally do not identify whether or not a sale price is inclusive or exclusive of GST. Unless it has been necessary and possible to specifically verify the GST status of a particular sale, it has been assumed that available sale price data has been transacted on a GST inclusive (if any) basis, which is in accordance with standard industry practice for most residential property. Should this interpretation not be correct for any particular sale or rental used as evidence, we reserve the right to reconsider our value estimate.

Land survey

We have made no survey of the property and assume no responsibility in connection with these matters. Unless otherwise stated, it is assumed all improvements lie within the title boundaries.

Unless otherwise stated, we have not undertaken investigations or been supplied with geotechnical reports with respect to the nature of the underlying land. Unless otherwise stated, we have assumed the land to be firm and suitable ground for the existing and/or potential development without the need for additional and expensive foundation and retaining work or drainage systems.

Contamination

Unless otherwise stated our report assumes that the land and buildings are unaffected by harmful contaminants or noxious materials which may impact on value. Verification that the property is free from contamination and has not been affected by noxious materials should be obtained from a suitably qualified environmental expert.

Market value estimates

This report is not a valuation and the market value estimate has not been carried out in accordance with the Valuation Standards and Guidance Notes recommended by the New Zealand Institute of Valuers and the Property Institute of New Zealand. The definition of Market Value is “the estimated amount for which an asset or liability should exchange on the date of valuation between a willing buyer and a willing seller in an arm’s length transaction, after proper marketing and where the parties have each acted knowledgeably, prudently and without compulsion”.

Our value estimates are subject to a full inspection of the property before a valuation assessment can be undertaken. This may result in a material adjustment to the value estimate herein provided.

No allowances are made in our value estimates for any expenses of realisation or to reflect the balance of any outstanding mortgages either in respect of capital or interest accrued thereon.

Mortgage lending

The value estimate provided in this advisory report may not be relied upon for mortgage lending purposes. Full inspections are mandatory where values are assessed for mortgage lending purposes.

Professional indemnity cover

We have in force at the time of supplying the above value estimate, current professional negligence insurance appropriate to the nature and level of our business activities.

Please contact the writer should you wish to discuss any matters raised in this report.

Yours faithfully

TelferYoung (Tauranga) Limited



Michael Reay

ANZIV, MPINZ

Registered Valuer

Director

E michael.reay@telferyoung.com

APPENDIX A

RECORDS OF TITLE



**RECORD OF TITLE
UNDER LAND TRANSFER ACT 2017
FREEHOLD
Search Copy**



Identifier 786686
Land Registration District South Auckland
Date Issued 08 June 2017

Prior References
H978435

Estate Fee Simple
Area 541 square metres more or less
Legal Description Lot 1 Deposited Plan 28153
Purpose Parking Purposes

Registered Owners
Tauranga City Council

Interests

11085023.1 CERTIFICATE PURSUANT TO SECTION 77 BUILDING ACT 2004 THAT THIS COMPUTER REGISTER IS SUBJECT TO THE CONDITION IMPOSED UNDER SECTION 75(2) (ALSO AFFECTS SA25B/1193, SA27A/838 and SA780/237) - 12.4.2018 at 2:24 pm

Identifier

786686

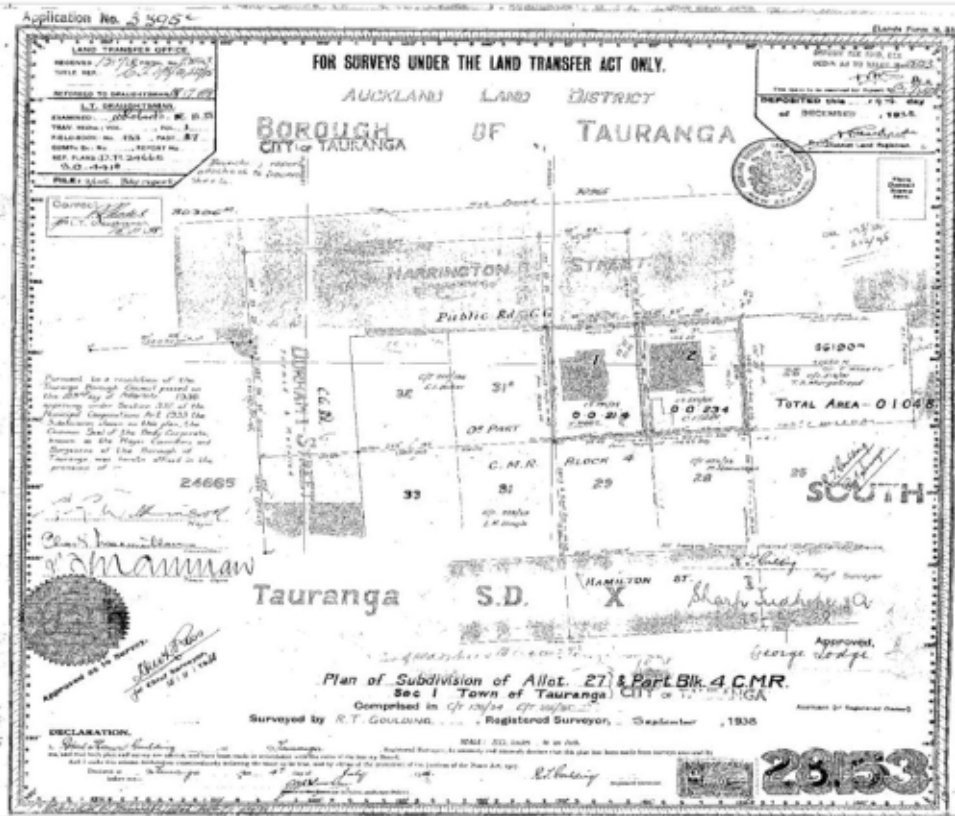

Transaction Id
Client Reference rmlnsmth001

Search Copy Dated 18/05/20 10:57 am, Page 2 of 2
Register Only



**RECORD OF TITLE
UNDER LAND TRANSFER ACT 2017
FREEHOLD
Search Copy**



Identifier SA780/237
Land Registration District South Auckland
Date Issued 01 September 1941

Prior References
SA223/59

Estate Fee Simple
Area 567 square metres more or less
Legal Description Part Block 4 Church Mission Reserve

Registered Owners
Tauranga City Council

Interests

11085023.1 CERTIFICATE PURSUANT TO SECTION 77 BUILDING ACT 2004 THAT THIS COMPUTER REGISTER IS SUBJECT TO THE CONDITION IMPOSED UNDER SECTION 75(2) (ALSO AFFECTS 786686, SA25B/1193 and SA27A/838) - 12.4.2018 at 2:24 pm

Transaction Id
Client Reference rmlinesmith001

Search Copy Dated 18/05/20 1:35 pm, Page 1 of 2
Register Only

Identifier

SA780/237

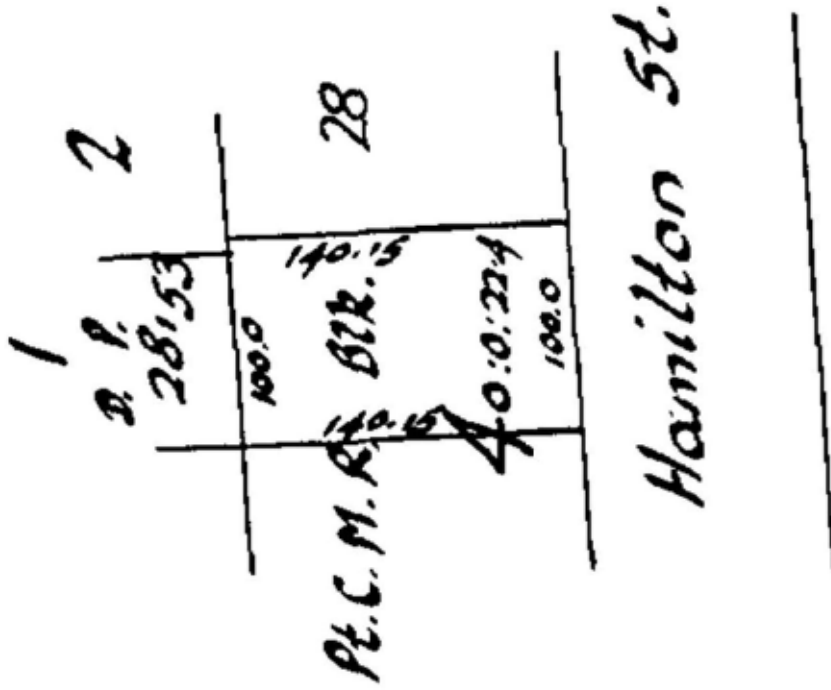

Transaction Id
Client Reference rmlnesmith001

Search Copy Dated 18/05/20 1:35 pm, Page 2 of 2
Register Only



**RECORD OF TITLE
UNDER LAND TRANSFER ACT 2017
FREEHOLD
Search Copy**



Identifier SA27A/838
Land Registration District South Auckland
Date Issued 22 July 1981

Prior References
SA492/22

Estate	Fee Simple
Area	564 square metres more or less
Legal Description	Lot 1 Deposited Plan South Auckland 29835

Registered Owners
Tauranga City Council

Interests

11085023.1 CERTIFICATE PURSUANT TO SECTION 77 BUILDING ACT 2004 THAT THIS COMPUTER REGISTER IS SUBJECT TO THE CONDITION IMPOSED UNDER SECTION 75(2) (ALSO AFFECTS 786686, SA25B/1193 and SA780/237) - 12.4.2018 at 2:24 pm

Transaction Id
Client Reference rmlnesmith001

Search Copy Dated 18/05/20 10:59 am, Page 1 of 2
Register Only

Identifier

SA27A/838

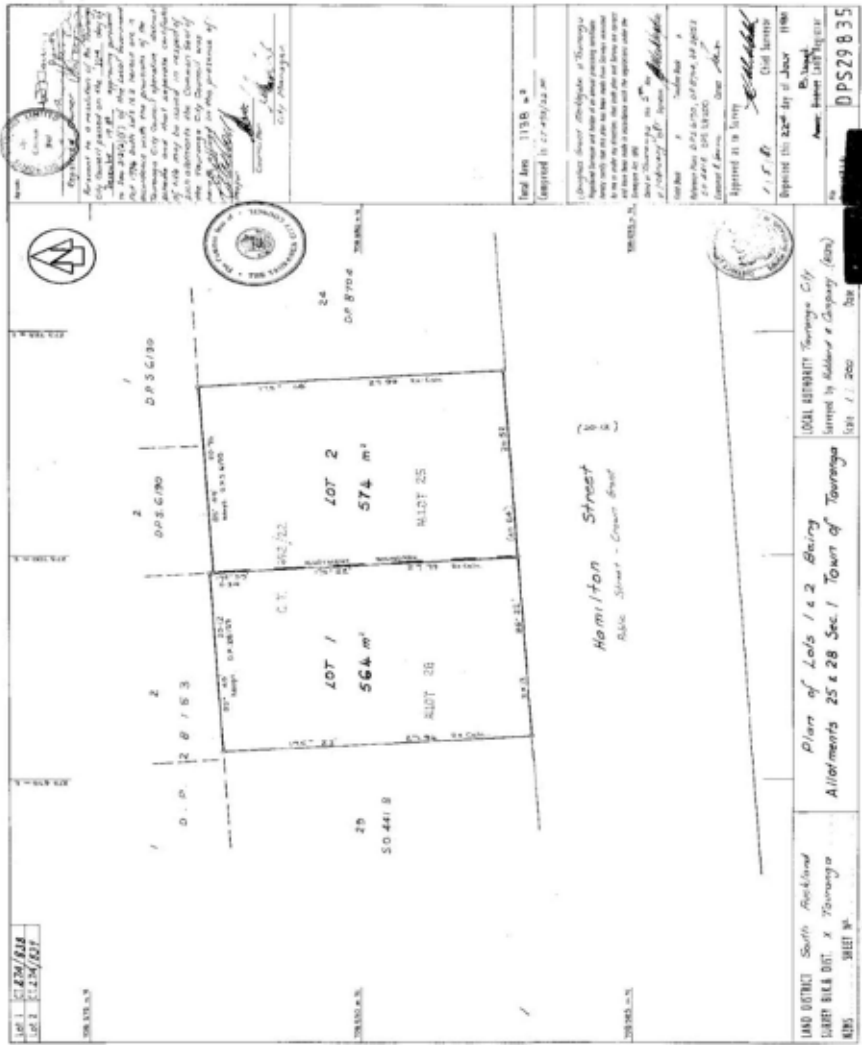

Transaction Id
Client Reference rmlnsmth001

Search Copy Dated 18/05/20 10:59 am, Page 2 of 2
Register Only



**RECORD OF TITLE
UNDER LAND TRANSFER ACT 2017
FREEHOLD
Search Copy**



Identifier SA25B/1193
Land Registration District South Auckland
Date Issued 15 October 1979

Prior References
SA708/360

Estate Fee Simple
Area 591 square metres more or less
Legal Description Lot 2 Deposited Plan 28153

Registered Owners
Tauranga City Council

Interests

11085023.1 CERTIFICATE PURSUANT TO SECTION 77 BUILDING ACT 2004 THAT THIS COMPUTER REGISTER IS SUBJECT TO THE CONDITION IMPOSED UNDER SECTION 75(2) (ALSO AFFECTS 786686, SA27A/838 and SA780/237) - 12.4.2018 at 2:24 pm

Transaction Id
Client Reference rmlinesmith001

Search Copy Dated 18/05/20 1:32 pm, Page 1 of 2
Register Only

Identifier

SA25B/1193

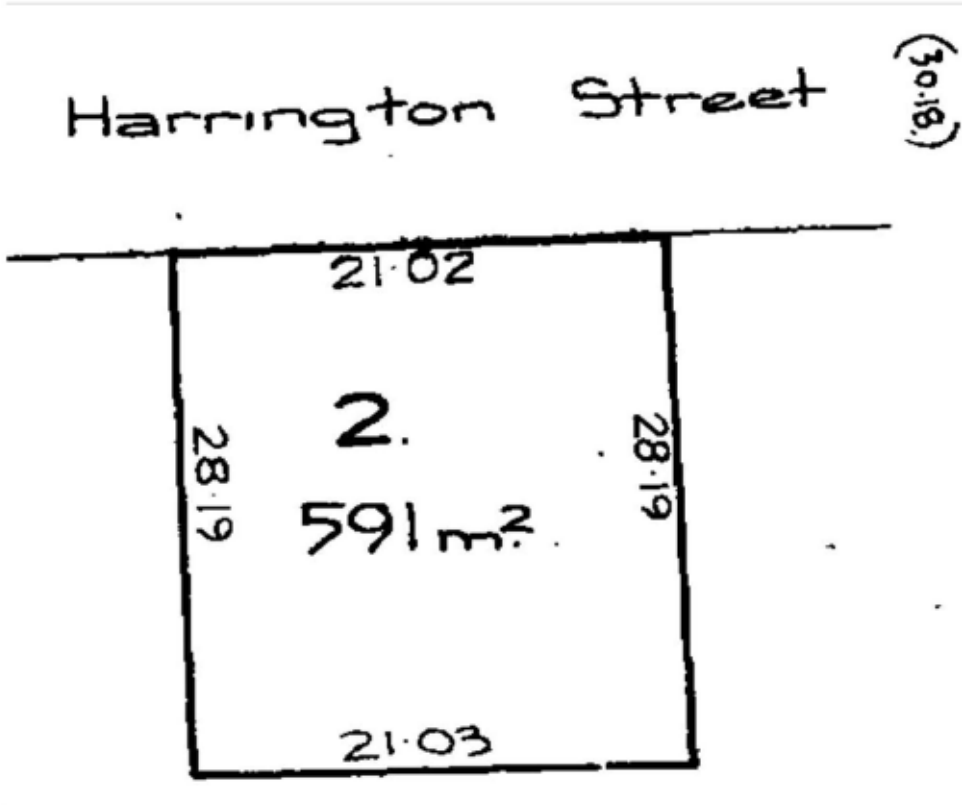

Transaction Id
Client Reference rmlinesmith001

Search Copy Dated 18/05/20 1:32 pm, Page 2 of 2
Register Only

APPENDIX B

MARKET SALES EVIDENCE

199 to 213 Cameron Road, CBD



Sale date	24 October 2018
Sale price	\$6,250,000
Area	2192 m ² (more or less)
Rate/m²	\$2,691.61/m ²

This is a City Centre zoned site held in three titles. The combined property has a wide frontage to Cameron Road and also a narrow access at the rear of the site from Williams Street. The site is situated on the western fringe of the Central Business District and at the time of sale was subject to two leases (both of expiring in September 2020). There are various improvements on each site, which we understand are all owned by the lessees. In addition there was a lease over adjacent land which is sublet and this tenancy also expires in September 2020. The land is appropriate for redevelopment and we understand that this is the intention of the purchaser. The leases at the site provide useful holding income until a development can commence.

60 Harington Street, CBD



Sale date	9 April 2018
Sale price	\$8,025,000
Area	2755 m ² (more or less)
Rate/m²	\$2,386.57/m ²

This is a 2,755 square metre city centre zoned site with frontage to Harington, Cameron, Durham and Hamilton Streets. The site is currently developed with a motel and a vacant small office building. The lease on the Motel expired on 29 July 2018 and the value of the property is mainly determined by its redevelopment potential. The property is in height zone 1 and buildings to a height of 49 metres above the Moturiki Datum can be built. This property lies approximately 16 metres above the Moturiki Datum.

2 Rata Street, Mount Maunganui



Sale date	28 March 2018
Sale price	\$5,600,000
Area	2118 m ² (more or less)
Rate/m²	\$2,644.00/m ²

The property is located to the strategic corner of Rata Street and Mount Maunganui towards the southern end of the Mount Maunganui town centre. Developed as a tavern in the 1950's but the property now has potential for redevelopment in the short to medium term. Our analysis recognises estimated cost of demolition and that the lease includes a demolition clause enabling 12 months notice of termination of the lease.

69 Spring Street, Tauranga



Sale date	7 December 2017
Sale price	\$6,000,000
Area	2461 m ² (more or less)
Rate/m²	\$2,520.00/m ²

A prominent corner site comprised of 4 individual titles within the Tauranga CBD. The land is located diagonally opposite the new university campus and is a short walking distance to the centre of the CBD. The site was improved with a 1950s building of 2,000 square metres, with retail tenancies on the ground floor and former education space to the remainder. Only the retail tenancies and two very small offices were leased at the time of sale. The property was returning approximately \$200,000 p.a. The building has IEP of 42% and is of utilitarian design that would be problematic to modernise. We understand that it was not feasible to use the existing structure and the property was purchased by a local developer for redevelopment. The sale price reflects \$2,438 per square metre. Alternative analysis on a redevelopment approach allowing for building demolition costs, partially offset by 2 years holding income derives a land value of \$2,520 per square metre.

124 Willow Street, Tauranga



Sale date	1 April 2017
Sale price	\$1,100,000
Area	630 m ² (more or less)
Rate/m²	\$1,746.03/m ²

A single storey retail building originally constructed in 1930 but refurbished in recent years. The building has a modern street frontage and presentation and internally the presentation is of above average quality. The property occupies a site of 630 sqm and has 5 carparks at the rear. The property has IEP of 17% which must be fixed by 2019. The building is vacant and yield on market income is 8.2%. Analysis reflects a land value of \$1,825 psm after deducting demolition costs.

93 Durham Street, Tauranga



Sale date	14 February 2017
Sale price	\$1,391,304
Area	808 m ² (more or less)
Rate/m²	\$1,721.91/m ²

A city centre zoned site at the fringe of the Tauranga CBD that is currently improved with a 1930s dwelling of 210 sqm. The site is located next to the new Waikato University's, Tauranga Campus (under construction at sale date) and was purchased by the owner of the two adjoining buildings that front Spring Street, on the property's northern boundary. The site is of steep contour, with adjoining land having been levelled at road level. High level indicative costs to level the site are in the range of \$50,000 to \$100,000. The sale price was \$1,600,000 including GST.

71 Devonport Road, Tauranga



Sale date	28 October 2016
Sale price	\$1,900,000
Area	835 m ² (more or less)
Rate/m²	\$2,275.45/m ²

A regular shaped commercial site within the central area of Tauranga's CBD. The site was improved with old commercial building with 11% NBS that will be demolished for the development of a new Quest hotel with circa 40 apartments. Was sold with estimated net holding income of \$90,000 p.a. plus GST.

NATIONWIDE

NATIONAL OFFICE

TelferYoung Limited
L5, 55 Shortland Street
PO Box 105553, Auckland City 1143

TelferYoung (Northland) Limited

17 Hatea Drive
PO Box 1093, Whangarei 0140
E northland@telferyoung.com
T +64 9 438 9599

TelferYoung (Rotorua) Limited

1243 Ranolf Street
PO Box 2121, Rotorua 3040
E rotorua@telferyoung.com
T +64 7 348 1059

TelferYoung (Nelson Marlborough) Limited

L3, 105 Trafalgar Street
PO Box 621, Nelson 7040
E nelson@telferyoung.com
T +64 3 546 9600

L1, 1 Hutcheson Street
Blenheim 7201
E nelson@telferyoung.com
T +64 3 577 6060

TelferYoung (Auckland) Limited

L7, 52 Swanson Street
PO Box 5533, Auckland 1142
E auckland@telferyoung.com
T +64 9 379 8956

218 Lake Road, Northcote
PO Box 36030,
North Shore City 0748
E northshore@telferyoung.com
T +64 9 480 2330

TelferYoung (Taranaki) Limited

143 Powderham Street
PO Box 713, New Plymouth 4340
E taranaki@telferyoung.com
T +64 6 757 5753

TelferYoung (Canterbury) Limited

L1, 58 Armagh Street
PO Box 2532, Christchurch 8140
E canterbury@telferyoung.com
T +64 3 379 7960

17 Dee Street
Timaru 7910
E canterbury@telferyoung.com
T +64 3 687 1220

L1, 130A Percival Street
PO Box 138, Rangiora 7440
E rangiora@telferyoung.com
T +64 3 313 5355

TelferYoung (Waikato) Limited

7 London Street
PO Box 616, Hamilton 3240
E waikato@telferyoung.com
T +64 7 839 2030
+64 7 871 5032 (Te Awamutu)
+64 7 889 5990 (Morrisonville)
+64 7 827 2030 (Cambridge)

TelferYoung (Hawkes Bay) Limited

25 Pandora Road
PO Box 572, Napier 4140
E hawkesbay@telferyoung.com
T +64 6 835 6179

7 Gladstone Road, Gisborne 4010
E hawkesbay@telferyoung.com
T +64 6 868 8596

TelferYoung (Otago) Limited

L3, 8 The Octagon
PO Box 497, Dunedin 9054
E otago@telferyoung.com
T +64 3 477 5796

TelferYoung (Tauranga) Limited

L2, 49-51 The Strand
PO Box 455, Tauranga 3144
E tauranga@telferyoung.com
T +64 7 578 4675

81 Jellicoe Street, Te Puke 3119
E tauranga@telferyoung.com
T +64 7 573 8220

TelferYoung (Wellington) Limited

L4, 94 Dixon Street
Wellington 6011
E wellington@telferyoung.com
T +64 4 472 3683

TelferYoung (Southland) Limited

135 Spey Street
PO Box 370, Invercargill 9840
E southland@telferyoung.com
T +64 3 218 4299

23 Medway Street
PO Box 334, Gore 9740
E southland@telferyoung.com

Project Name: Harington Street Transport Hub
To: Nick Johansson / James Woodward (TCC)
Prepared by: Malcolm Sabourin TSA
Subject: Status Update Report Report – (Updated 20th May)
Report Period: To: Sunday 17th May 2020

1.0 OVERVIEW

This update report is intended to inform Council and the PAB of changes in status of technical workstreams following the PAB meeting on the 23rd April 2020 and the subsequent briefing of Executive briefing held on Monday 11th May 2020. We have only focused on the changes during the period to allow the PAB to advise and endorse the upcoming report to Council,

Design

The Harrison & Grierson strengthening design continues to be challenged by the Peer Reviewer (Aurecon). The floor diaphragm and mechanism for transfer of loads from basement strengthening to the adjacent structure being two key areas for which a satisfactory solution has not currently been demonstrated.

The scope of works continues to increase as the structural model is analysed and elements are identified as lacking in the necessary strength to comply with relevant structural codes.

Option Studies

Of the 4 Option Studies the scope of Demolition and Demolition and Rebuild has been reviewed since the last PAB meeting. [REDACTED]

[REDACTED] In addition the scope of Demolition has been adjusted to account for works required to leave the site in a safe condition.

Cost Estimates

Previous discussions have identified concerns that the estimate for Option A (H&G Strengthening) is likely to increase. Since the last report additional scope has added \$2m to the RLB estimate. As of writing this report and based on the information currently available the cost of the Strengthening Option now stands at \$55.4m. This value includes a design development contingency which covers changes to known design elements but not any additional items which are introduced. We have therefore amended the accuracy of the overall cost estimate from plus/ minus 10% to plus 15%/minus 0% . This makes allowance for anticipated further increases in scope to cover design elements which are anticipated to resolve the diaphragm and basement load transfer solutions. As of writing this report that cost estimates for each of the options are as follows:

- Option A – Current design solution \$55.4m
- Option B - Demolition leaving only a basement \$26.2m
- Option C –Demolition and rebuild carpark using a conventional structural solution **\$62.6m**
- Option D –Reduction in height by 4 floors \$47.6m

Buildability.

Watts & Hughes have further developed strategies for controlling noise levels generated by both sandblasting of steelwork and hydro excavation of concrete within localised areas of the basement walls. They have confirmed that this will be possible albeit with a cost premium to build acoustic walls around the work areas. This was a significant concern which can now be considered as closed.

Programme

Due to the incomplete design documentation it has not been possible for Watts & Hughes to engage with their steelwork subcontractor to develop a price for the works. There is a reluctance to price works which continue to change in detail resulting in abortive efforts. For this reason we are waiting to reach a point where the Peer Reviewer is satisfied with the solutions before distributing documentation.

Once design is substantially complete there will be a 4-5 week period during which pricing can be undertaken in parallel with a superstructure building consent package being submitted for processing.

As of writing this report Harrison & Grierson are unable to advise when they can have their design ready for a completion milestone.

2.0

DESIGN

Building Superstructure

Key Areas of Design

There continues to be ongoing dialog between Aurecon and Harrison and Grierson aimed at the designer proving that their solution is compliant with code. Once resolved to Aurecon's satisfaction a PS2 will be provided which is required to obtain a Building Consent for the works.

The design adequacy of the floor diaphragm and the transfer of loads from the basement strengthening components into the adjacent structure remain two key areas which have not been resolved since our last report. Based on comments generated by Aurecon there are elements which are not detailed within the design documents which adequately demonstrate the full scope of works required. Hence, we anticipate as these works are defined there will be a further upward movement in price.

Increased Scope

The structural model continues to be run as each design component is refined. As a result, there has been further increase in the scope to the strengthening works which has been identified in correspondence between H&G and Aurecon. These items include:

- Additional column / beam connection strengthening in the lower levels
- Increased number of Inerd Pin connections which need to be modified. Where possible these will be removed from the site and works undertaken within the steel fabricators yard to achieve the required tight tolerances.

The cost of these elements has been estimated and included with the current cost update.

As previously noted in TSA reports, we are progressively redesigning elements of the building as issues are identified and inadequacies brought to the fore. The extent of redesign is not commonly experienced to this extent in a peer review process.

3.0 WATTS & HUGHES

Pricing of the Works

With Covid Level 2 now in place this provides an opportunity for Watts and Hughes to progress meaningful engagement with their suppliers and subcontractors. The key subcontractor being Jensens who will price the Steelwork modifications. To undertake this pricing the completed H&G design is required as there is a reluctance to commit resource when design details and scope continue to change.

Until the H&G design is completed and accepted by Aurecon we are holding off distributing further documents. Watts and Hughes however are continuing to engage with supplies and advisors to refine their methodologies in areas where the Covid 19 level 4 restrictions prevented meaningful dialog. The key area being acoustic control at the site boundaries as a result of the use of sandblasting and hydro- excavation equipment. The current planning involves acoustic barriers constructed around the work elements which would allow the noisy works to be completed and then allow the barrier to be relocated to other areas

Site Security / Health and Safety

- The site continues to be under the control of Watts & Hughes with no incidents reported during the last period
- The site currently is operating under revised H&S processes to reflect the Covid 19 threat. As there is no construction activity currently underway these measures are not onerous, and distancing is relatively easily achieved.

4.0 FINANCIAL

Financial Work Stream 1 – Watts and Hughes Pricing

- Further development of a price to undertake the works is dependant of the completion of the Harrison & Grierson structure design details and providing response to clarifications requested by Watts & Hughes.

Financial Work Stream 3– Parallel Cost Estimates for Strengthening Option

- There has been no further need to engage with Cuesko during the latest reporting period.

Financial Work Stream–4 Options Studies

The following Options Studies have been prepared and presented to the PAB so that further financial modelling can be undertaken to assist in decision making:

- Option A – Current design solution
- Option B - Demolition leaving only a basement
- Option C – Demolition and rebuild carpark using a conventional structural solution.
- Option D – Reduction in height by 4 floors

During the last 2 weeks and following feedback from the PAB. TSA and Rider Levett Bucknall have undertaken a further review of Options A,B&C. As a result, the estimated costs of these three options have been adjusted as follows:

- a) Option A Structural Strengthening.
-

- Increased quantity of Inerd connections requiring remedial works as a result of further modelling of the structure
 - Further increase in scope required to strengthen beam / column connections within the lower levels of the building
 - Overall upward movement of \$2m
- b) Option B Demolition
- Cost estimates adjusted to reflect additional works to leave the site in a safe condition and allow access to maintain the site
- [Redacted text]
- c) Option C – Demolition and Rebuild
- [Redacted text]

In addition to the increased cost estimate we have (in consultation with RLB) adjusted the accuracy of the cost estimates for Option A. This option has a design contingency within the estimate for the refinement of known design details. It did not however reflect further increase in scope of the works which has been evident. Based on recent questions being raised by Aurecon we anticipate the H&G response will be further new elements of design which are not currently documented and therefore missing from the estimates. To account for this the accuracy of the estimate has been amended from plus/minus 10% to plus 15/minus zero %. In summary we do not expect the strengthening option to reduce in value as new design details and therefore scope continues to be added.

The amended cost estimates have therefore been adjusted as follows:

[Redacted]	[Redacted]	[Redacted]	[Redacted]
[Redacted]	[Redacted]	[Redacted]	[Redacted]
[Redacted]	[Redacted]	[Redacted]	[Redacted]
[Redacted]	[Redacted]	[Redacted]	[Redacted]
[Redacted]	[Redacted]	[Redacted]	[Redacted]
[Redacted]	[Redacted]	[Redacted]	[Redacted]
[Redacted]	[Redacted]	[Redacted]	[Redacted]
[Redacted]	[Redacted]	[Redacted]	[Redacted]
[Redacted]	[Redacted]	[Redacted]	[Redacted]
[Redacted]	[Redacted]	[Redacted]	[Redacted]
[Redacted]	[Redacted]	[Redacted]	[Redacted]
[Redacted]	[Redacted]	[Redacted]	[Redacted]
[Redacted]	[Redacted]	[Redacted]	[Redacted]
[Redacted]	[Redacted]	[Redacted]	[Redacted]
[Redacted]	[Redacted]	[Redacted]	[Redacted]
[Redacted]	[Redacted]	[Redacted]	[Redacted]
[Redacted]	[Redacted]	[Redacted]	[Redacted]
[Redacted]	[Redacted]	[Redacted]	[Redacted]
[Redacted]	[Redacted]	[Redacted]	[Redacted]
[Redacted]	[Redacted]	[Redacted]	[Redacted]

[REDACTED]	[REDACTED]	[REDACTED]	[REDACTED]	[REDACTED]
[REDACTED]	[REDACTED]	[REDACTED]	[REDACTED]	[REDACTED]
[REDACTED]	[REDACTED]	[REDACTED]	[REDACTED]	[REDACTED]
[REDACTED]	[REDACTED]	[REDACTED]	[REDACTED]	[REDACTED]
[REDACTED]	[REDACTED]	[REDACTED]	[REDACTED]	[REDACTED]
[REDACTED]	[REDACTED]	[REDACTED]	[REDACTED]	[REDACTED]
[REDACTED]	[REDACTED]	[REDACTED]	[REDACTED]	[REDACTED]
[REDACTED]	[REDACTED]	[REDACTED]	[REDACTED]	[REDACTED]
[REDACTED]	[REDACTED]	[REDACTED]	[REDACTED]	[REDACTED]
[REDACTED]	[REDACTED]	[REDACTED]	[REDACTED]	[REDACTED]
[REDACTED]	[REDACTED]	[REDACTED]	[REDACTED]	[REDACTED]
[REDACTED]	[REDACTED]	[REDACTED]	[REDACTED]	[REDACTED]

5.0 PROGRAMME

With little progress being made in the last reporting period to resolve the two key areas of design it is difficult to advise on timing for the Superstructure Peer Review to be concluded due to H&G delivery dates not being achieved and the programme continuing to slide.

Once design is substantially complete there will be a 4-5 week period during which pricing can be undertaken in parallel with a superstructure building consent package being submitted for processing.

6.0 [REDACTED]

[REDACTED]

[REDACTED]

[REDACTED]

[REDACTED]

[REDACTED]

[REDACTED]

[REDACTED]

[REDACTED]

[REDACTED]

[REDACTED]

[REDACTED]

[REDACTED]

[REDACTED]

[REDACTED]

[REDACTED]

[REDACTED]

[REDACTED]

[REDACTED]

[REDACTED]

[REDACTED]

[REDACTED]

[REDACTED]

[REDACTED]

- [Redacted]

RISKS -New Risks Identified in Bold

Emerging Key Risks	Risk	Rating	Mitigation
	<u>Achieving Design Solution</u> There is a risk that there is not a practical and economical solution to resolve the three fundamental areas of design which include: <ul style="list-style-type: none"> • Pin and associated plate modifications • Diaphragm action • Splice and Column Joints 	High	H&G are responding to Aurecon RFI's challenging the design. Buildability advice is being sought from Jensen's to ensure that the design solution can be achieved Cost estimates have been prepared with a parallel exercise undertaken by Cuesko. Pricing by Watts & Hughes will be undertaken once design I accepted by Arecon.
	<u>Steel Primer</u> There is a risk that the steel primer on the upper levels is no longer effective due to the length of time it has been exposed and will require replacement	High	Testing proposed to try and determine extent of the issue . An estimate of extent will need to be the basis of the W&H pricing.
	<u>Noise and Dust</u> Should replacement of the primer be required this is require sandblasting to prepare the surface. The noise levels will exceed boundary maximum levels	High	Watts & Hughes enlisting the advice of an acoustic engineer to advise on noise containment initiatives Agreement maybe required with adjacent property owners to allow periods where noise levels exceed boundary controls. Currently noise barriers have been allowed to control noise levels albeit at a cost premium.
	<u>Hydro excavation</u> There is a risk that the noise levels resulting from using Hydro Excavation techniques will exceed the permissible maximum boundary levels	High	Watts & Hughes have consulted with an acoustic engineer to develop noise screening methodologies. Agreement maybe required with adjacent properties to allow periods where noise levels exceed boundary controls.
	<u>Cost Certainty</u> There is a risk that either extent of works or methodologies present risk to subcontractor result in subcontractors not being willing to fix their prices	High	Watts & Hughes being advised that Councils expectation is that a fixed price lump sum is required to keep pressure on for an acceptable price submission.

Quality

Med

This risk is difficult to mitigate.

Added strengthening will be visible on completion of the project which may attract comment and add operating costs higher than usual.

7.0**KEY ISSUES**

- Completion of H&G design of critical components to prove there is an overall viable design solution
 - Completion of H&G detailing of the works required for the Peer Review and pricing of the works
 - Completion of H&G design which allows Watts & Hughes pricing to progress.
 - Conclusion of Council High Level Project Options review.
-



TSA Management Limited
Level 2, 88 Broadway, Newmarket
Auckland 1023
+64 9 550 1427
hello@tsamgt.com
www.tsamgt.com

29th May 2020

Nic Johansson
GM Infrastructure
Tauranga City Council
Private Bag Tauranga 3134

By email: Nic.Johansson@tauranga.govt.nz

Dear Nic

Subject: Harington Street Transportation Hub – Options Study Cost Estimates

TSA assisted by the project cost consultants, Rider Levett Bucknall, have developed cost estimates for four option studies to assist Council with decisions on the future of the project. This has been necessitated following the identification of deficiencies in the original design which has required a strengthening solution to be developed by the design consultant, Harrison & Grierson.

The design solution was provided to the peer reviewer in advance of submitting for a building consent. With this information cost estimates were prepared to inform Council on the anticipated cost of the required works. The peer review process has been extensive and has identified significant issues which have necessitated further structural analysis and amendment to the design solution.

As amended design has been prepared, Rider Levett Bucknall have amended their estimates, however where design strengthening has not as yet been transferred to drawings it has been necessary to make monetary provisions. Currently the peer review is ongoing with some final key structural components to be analysed to address concerns raised by Aurecon. We anticipate that the final outcome will result in further works and associated costs to the Structural Remediation (Option A).

It should be noted that there are significant costs anticipated to undertake the works on a partially completed building due to challenges providing access and temporary support where elements of the building require to be replaced while the structure remains above. Allowance for these challenges is included in the estimates

The options investigated include:

1. Option A – Structural Remediation
2. Option B – Demolish and Demobilise
3. Option C – Demolish and Rebuild
4. Option D – Reduction in Height

As the design solution for Option A has not been completed it has not been possible to issue a full pricing package to Watts & Hughes for pricing. Hence we are using cost estimates as a basis for decision making. To avoid relying totally on one estimate, Cuesko has been engaged to undertake a parallel exercise to provide a comparison using the same information available to RLB.

For Option C (Demolition and Rebuild) a check estimate has been prepared by Cuesko with a further estimate prepared WT Partnership.

For each Option, TSA and RLB have reviewed the outcomes of all estimates prepared and have made adjustments were required to normalise the results plus added costs outside that of pure construction to establish anticipated total project values.

The outcome is summarised in the following table with more detail and explanation contained in the Rider Levett Bucknall correspondence attached.

SUMMARY OF RLB COST ESTIMATE AND PARALLEL ESTIMATES PREPARED BY CUESKO AND WT PARTNERSHIP

OPTION A	RLB	Cuesko	WT	Average
Structural Remediation				
	\$55.41m	\$55.44m	NA	\$55.4m (-0/+15%)
OPTION B				
Demolition and Demobilise				
	\$25.97m	\$26.99M	NA	\$26.5m (+/-10%)
OPTION C				
Demolition and Rebuild				
	\$61.88m	\$69.84m	\$61.59m	\$64.4m (+/- 10%)
OPTION D				
Deconstruct 4 Levels and Finish at L4.5				
	\$47.6m	NA	NA	\$47.6m (+/- 10%)

Please note that the value expended to date on the project is **\$19.09m**

Yours sincerely,

Malcolm Sabourin

Director, TSA Management Limited

cc: James Woodward, TCC
Nathan Speir, Rice Speir Ltd

Attachment: RLB Report and Estimates

Transport Hub economic assessment

Final client version

02/06/2020

All content in this presentation should be considered legally privileged and commercially sensitive

**STAKEHOLDER
STRATEGIES**

AGENDA

Project background

Financial assessment

Wider assessment

Recommendation and next steps

PROJECT BACKGROUND (1)

In 2017 Tauranga City Council (TCC) entered into a contract to deliver a 550-car park building at 26 Harington Street

TCC's stated rationale focussed on the need to replace parking lost from waterfront and other Central Business District (CBD) areas

- We have reviewed the rationale and the evidence supporting it and are providing advice separately on both to the Chief Executive

After starting construction in June 2018, Watts and Hughes were instructed to halt works in September 2019¹

- Work was halted after a beam reacted poorly after a concrete pour, and the discovery of other design issues

PROJECT BACKGROUND (2)

A Project Advisory Board (PAB) have investigated the most cost-effective way to complete the building

- PAB have found that design flaws mean the building is going to cost at least \$26m more than the original budget to deliver a comparable building

Watts and Hughes¹ describe the remedial challenges as “numerous and logistically perplexing”², and state that as of May 2020, “they do not see a competent and complete design”²

- We have requested the PAB to allow for residual risk and uncertainty in providing its advice and have acted in reliance on that advice in our subsequent decision analysis

Our report assesses the economic viability of various forward options given the cost estimates produced by the PAB. Stakeholder Strategies has not undertaken separate engineering investigation

NOTES AND DISCLAIMERS

Content in the final version of this presentation is intended for Tauranga City Councillors, Chief Executive and Mayor only, and [REDACTED]
[REDACTED]

The content is highly commercially sensitive as it gives indications of how Council might assess the value of some assets and options

- Although the presentation contains some indicative values, our work and this presentation do not constitute formal valuation advice

The Project Advisory Board has provided inputs regarding indicative costs of the engineering options, [REDACTED], and McHale Group has reviewed the procurement process

- While every effort has been made to ensure accuracy and balance in assessing and integrating information, the accuracy of the outputs is conditional on the fullness and accuracy of the input information received from other parties.

Stakeholder Strategies has been engaged to work with Tauranga City Council to assess the strategic intent of the Transport Hub project, the rationale in the current strategic context, and to help Councillors find the best way forward

AGENDA

Project background

Financial assessment

Wider assessment

Recommendation and next steps

DEMOLITION OPTION MINIMISES LOSSES

Net present value has been used to compare the estimated financial performance of each option

Completion options all require substantial further cost

Demolition option minimises NPV losses

- Even with price rises and lower risk assumptions
- Value of Demolition option is driven by land and basement value inputs

Even under the most favourable assumptions, Completion still has a negative NPV

Based on the probabilities of value drivers for different options, Demolition has highest risk weighted value

NET PRESENT VALUE HAS BEEN USED TO COMPARE THE ESTIMATED FINANCIAL PERFORMANCE OF EACH OPTION

Net Present Value is the discounted sum of estimated expected future cash flows from a project

Net Present Value is forward looking and **excludes any costs sunk to date**, regardless of the option

For Completion options, this includes the cost to complete plus expected revenue from the completed project

For Demolition, we have weighed up the cost to demolish against the value of the site with any salvageable improvements (e.g. the basement works)

A discount rate is set to reflect the cost of capital and risk associated with a project, and future cash flows are reduced by the discount rate each year

COMPLETION OPTIONS ALL INVOLVE SUBSTANTIAL FURTHER COST

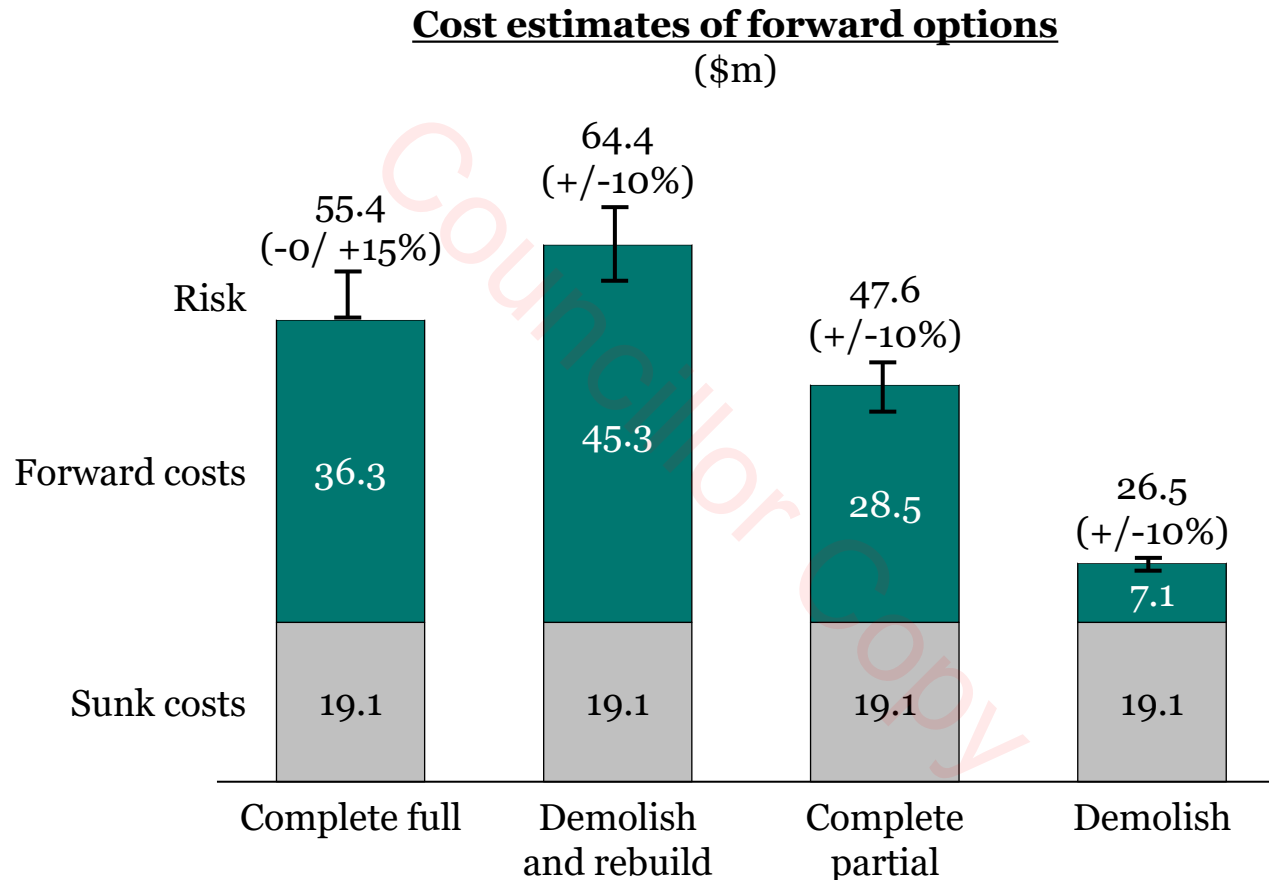

Source: TSA, May 29 2020. The risk component is the upper end of the completion cost estimates. Sunk costs \$19.09m.

Note: Complete full and demolish/rebuild both deliver 550 carparks, and complete partial delivers ~280

Risk ranges only applied to forward costs, per email communication from Ian Fraser and TSA, 20 May 2020.

OPERATIONAL AND DISPOSAL CASHFLOWS WERE CONSIDERED FOR EACH OPTION

Option assessment methodology

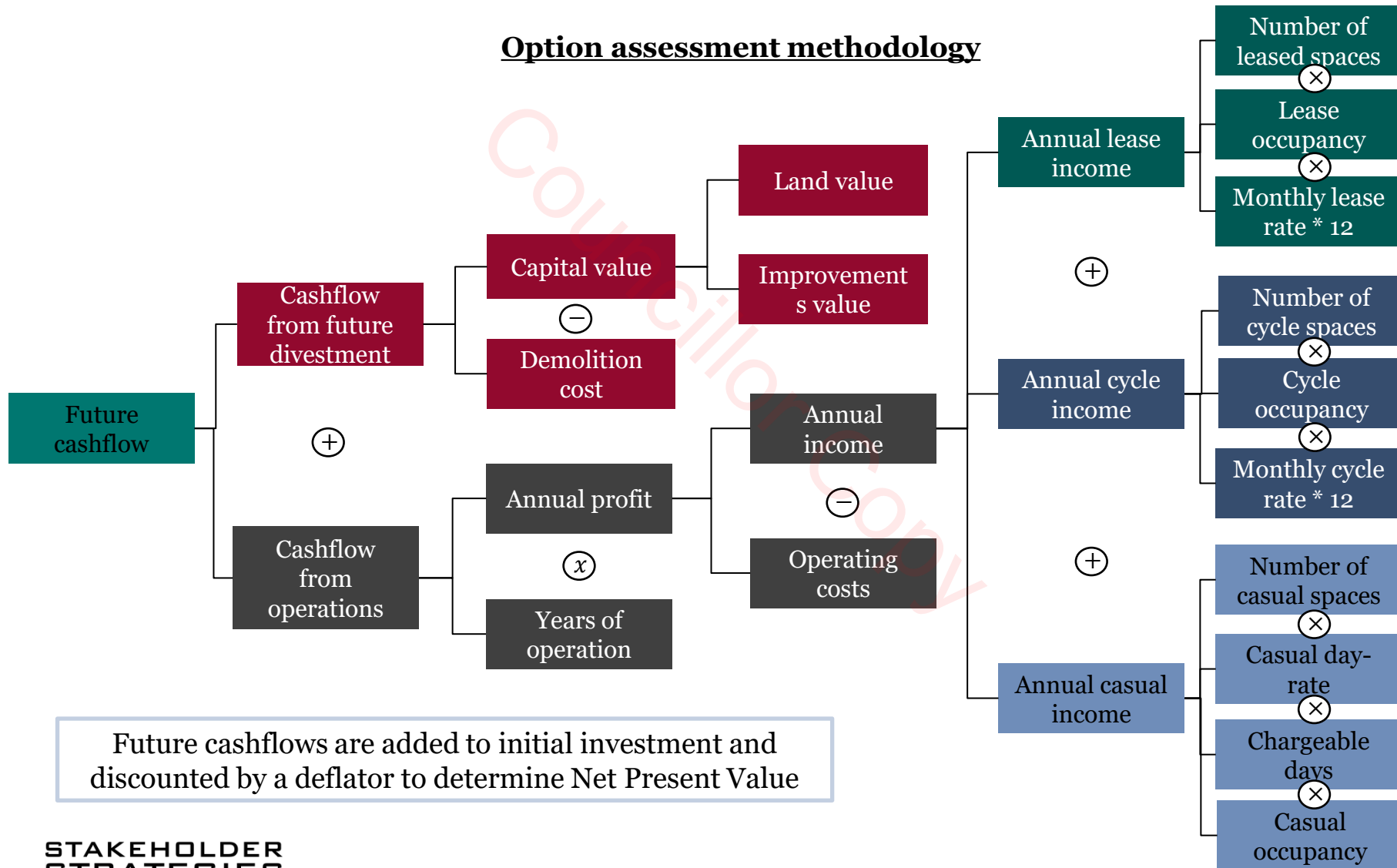

Future cashflows are added to initial investment and discounted by a deflator to determine Net Present Value

DEMOLITION MINIMISES NPV LOSSES, EVEN WITH PRICE RISES AND LOWER RISK ASSUMPTIONS

Indicative NPV of options
(\$m)

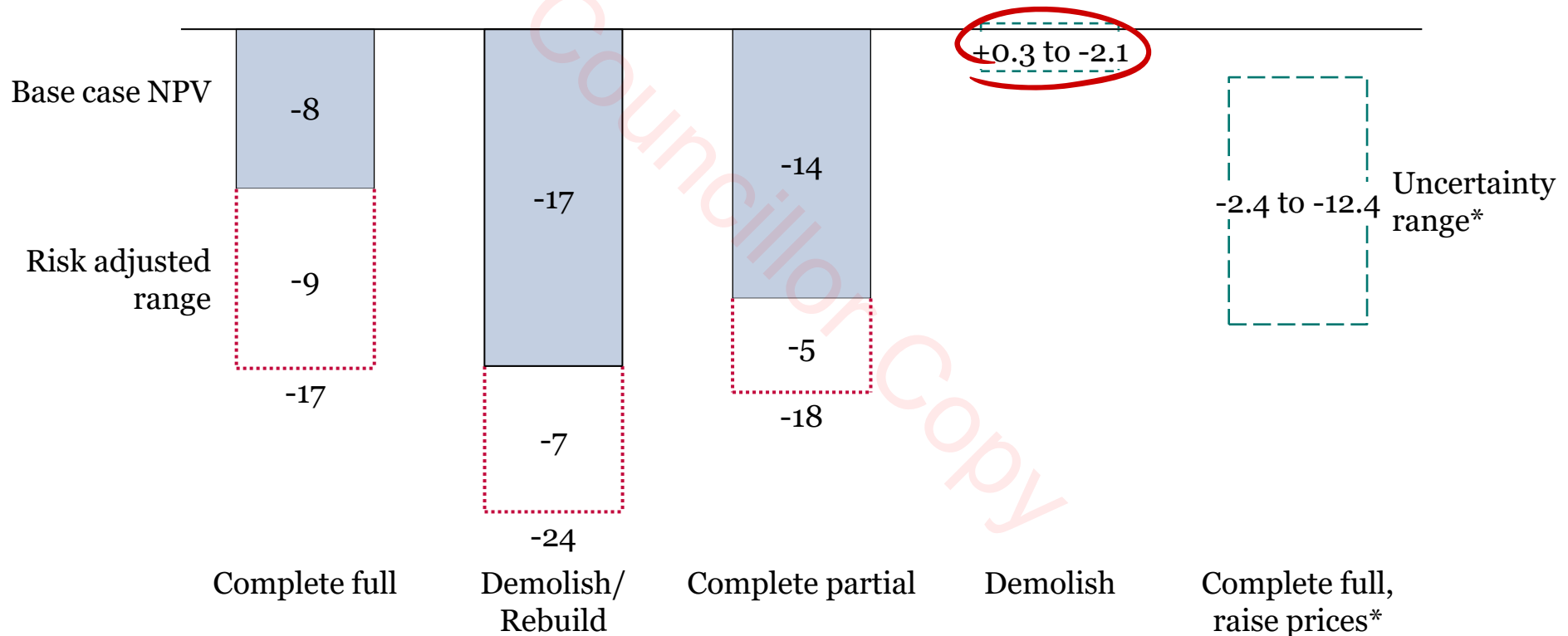

Note: Risk adjusted by increasing discount rate from 4% to 5% and taking upper estimates of completion costs.

VALUE OF DEMOLITION OPTION IS DRIVEN BY LAND AND BASEMENT IMPROVEMENT VALUES

Value matrix of 'demolish' option
(\$m NPV)

Value of basement improvements

	\$0	\$1m	\$2m
\$2250	-2.1	-1.2	-0.2
\$2375	-1.8	-0.9	0
\$2500	-1.6	-0.6	0.3

Value of land (/sqm)

[Redacted content]

EVEN UNDER THE MOST FAVOURABLE ASSUMPTIONS, COMPLETION NPV IS LOWER THAN DEMOLISH

Value matrix of ‘Complete and raise prices’ option¹ ((\$m NPV))

		Discount rate 5% ²		Discount rate 4% ²	
		Occupancy			
		70%-80%	80%-90%	70%-80%	80%-90%
Monthly lease price (\$)	254 (0% increase) ³	-12.4	-11	-8.7	-7.2
	267 (5% increase)	-10.8	-9.5	-6.9	-5.3
	292 (15% increase)	-8.5	-7	-4.1	-2.4

Notes: 1. Assumes no cost overrun from current estimates, so is optimistic.

2. Discount rate reflects Council’s low cost of capital. Discount rates discussed with TCC finance team.

3. 2020/21 Annual Plan sets monthly parking leases at \$230 for covered, \$290 for basement. The breakdown of spaces at Harington means average yield would be ~\$254/month/space. Increases are applied to casual day rates and rounded to nearest dollar (e.g. 5% increase = \$15/day, 15% increase = \$16/day).

BASED ON THE PROBABILITIES OF VALUE DRIVERS FOR DIFFERENT OPTIONS, DEMOLITION IS MOST VALUABLE

Decision	Uncertainty	Outcome NPV (\$m)	Probability weighted NPV	Probability weighted option value	
Complete and raise prices or demolish?	Complete and raise prices	Costs are +15%	30% Demand for parks high	-7.5	-1.28
			70% Demand for parks low	-9.1	-3.70
		Costs are +0%	30% Demand high	-2.4	-0.24
			70% Demand low	-4.1	-1.04
					-\$6.6m
	Demolish ¹	Basement value high	50% Value of site high	0.3	0.11
			50% Value of site low	-0.2	0.03
		Basement value low	50% Value of site high	-1.6	-0.42
50% Value of site low			-2.1	-0.60	
				-\$1.3m	

Note 1: Demolish option could apply to near future or pause as holding cost is low, so option value of waiting may be positive. Probabilities used are based on our perception of each uncertainty, our analysis, interviews with TCC staff and PAB members.

AGENDA

Project background

Financial assessment

Wider assessment

Recommendation and next steps

CONSTRAINTS ARISE FROM ABANDONING PROJECT, BUT OVERALL DEMOLITION IS STILL BEST OPTION

TCC's stated rationale for carpark was to support CBD development by absorbing pre-COVID forecast parking shortfall

- Pre COVID parking outlook included both supply and demand pressures
- Outlook is impacted by COVID-19 and other demand uncertainties

If parking demand grows at previously forecast rates, intervention will be required

When financial and other factors are considered together, Demolish performs best

STATED RATIONALE FOR TRANSPORT HUB WAS TO SUPPORT CBD DEVELOPMENT

Strategy	Aspects of strategy relevant to parking and development ²	Strategic alignment of carpark as stated by TCC ¹
City Centre Strategy (2012)	<ul style="list-style-type: none"> Strengthen CBD as the commercial centre, cultural heart, and as a quality retail destination within the Bay of Plenty Enhance civic role and education activities as well as provide quality open spaces “Reduce CBD traffic and promote other modes” Manage parking demand and provision to support the economic competitiveness of CBD. <ul style="list-style-type: none"> In short term address economic viability and competition from other centres and long-term support mode shift 	<ul style="list-style-type: none"> Carpark seen as supporting future CBD development Seeks to address potential parking supply shortfall Role of alternative supply accentuated given limited perceived demand side options Link to mode shift not clear
Transport Strategy (2012)	<ul style="list-style-type: none"> Deliver SmartGrowth and support increases in urban density³ Achieve a balanced network that provides a number of travel options and encourages alternative modes³ and healthier people Enable more efficient use of the transport network and management of demand Specific to parking – Seek an integrated policy and manage demand at 85% via time and price interventions 	<ul style="list-style-type: none"> Cyclist facility supports a balanced network Increased pricing at Transport Hub seen to encourage other modes But time and price interventions appear not to have been fully implemented

Note 1: We are reporting separately on our assessment of TCC’s rationale including process and evidential issues. Summarising perceived policy intent here does not imply SHS endorsement.

Source: TCC Interviews, TCC Documents (DC24, DC180, DC133, City Centre Strategy 2012, Tauranga Transport Strategy 2012)

Notes: 2. Includes stated desired outcomes and potential responses 3. Deliver SmartGrowth, supporting increases in urban density and alternative modes noted as potential responses for consideration

PRE COVID-19 TCC PARKING OUTLOOK INCLUDED SUPPLY AND DEMAND PRESSURES

Indicative sources of increasing pressure on parking stock (Demand and supply estimates over next ~5-8 years)

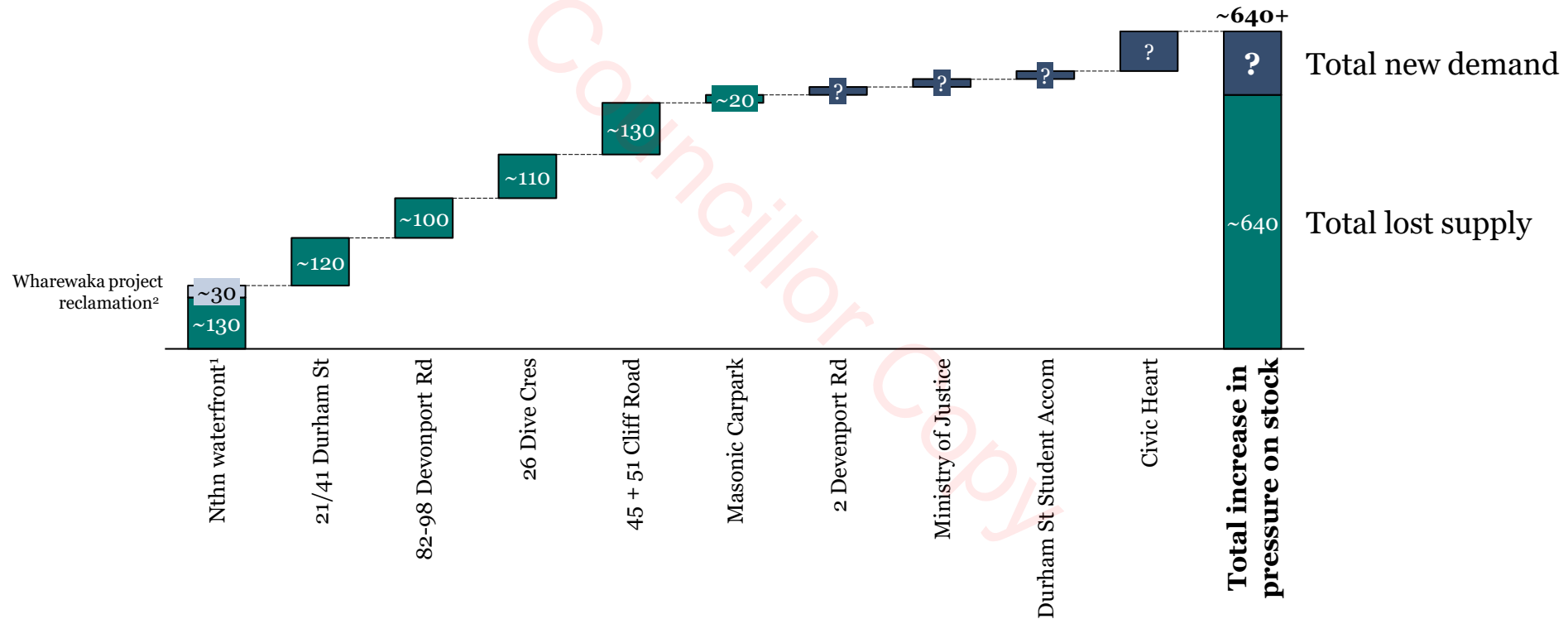

Note: Estimates are now outdated. COVID and evolving transport planning means reforecasting is required. Forecast does not include any organic growth in demand.

Source: TCC Interviews, TCC Documents

Notes: ¹ Removal of Northern waterfront carpark contingent on availability of replacement car parks

² One of the CIP economic stimulus projects in TCC's 'shovel-ready' funding applications

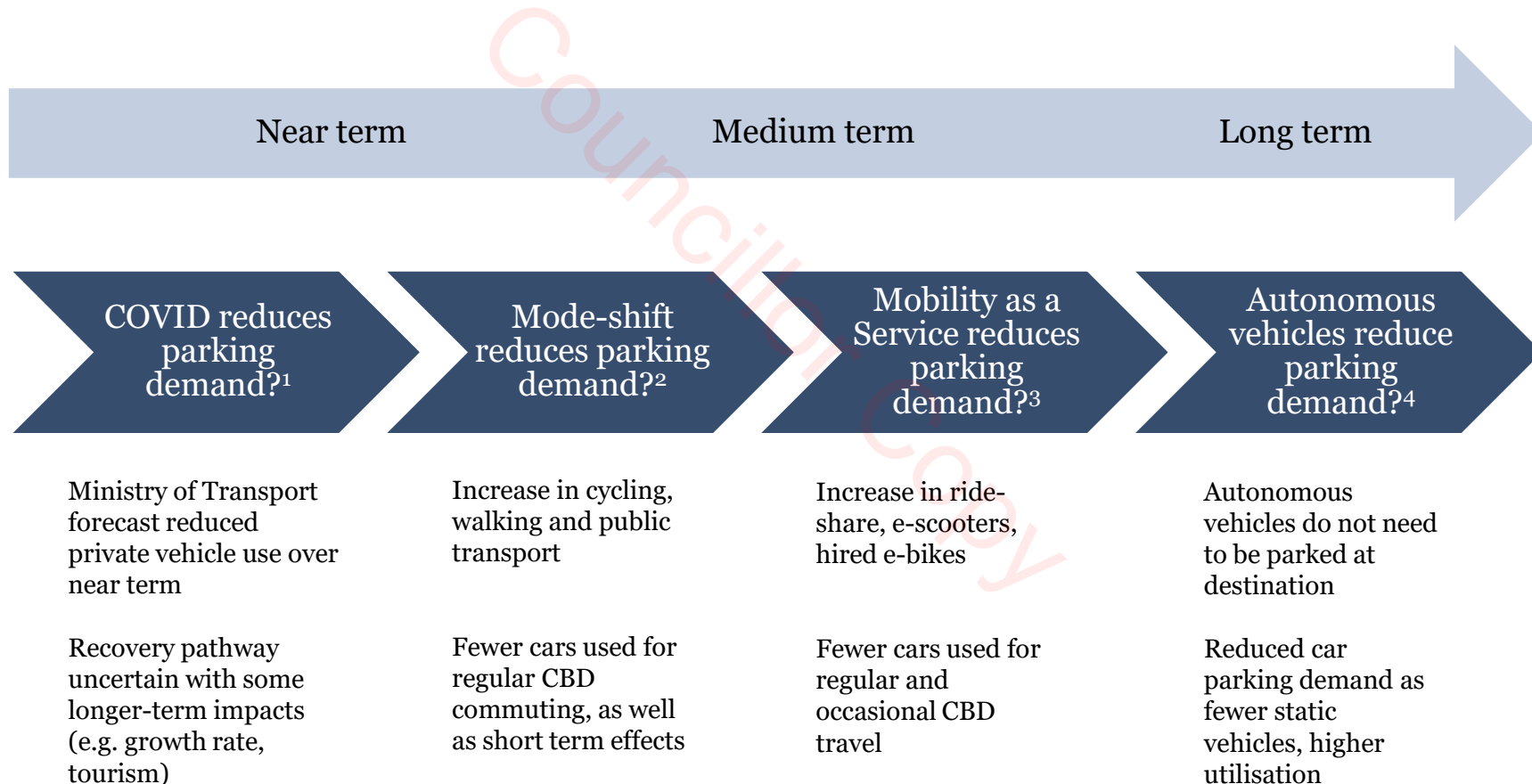

FORECASTS ARE UNCERTAIN DUE TO COVID-19 AND OTHER FUTURE DEMAND COMPRESSION FACTORS

Potential compression factors of future carpark demand



IF PARKING SUPPLY SHORTFALL OCCURS, ALTERNATIVE MANAGEMENT STRATEGIES ARE AVAILABLE

Impacts and management options arising from “Demolition” option

Perceived constraint ⁽¹⁾	Can it be navigated?	Impact of ‘Demolish’ option
Maintain sufficient CBD parking supply to meet demand	Yes, through optimised pricing, regulation or new (private) supply provision, and reforecast demand	 Partial impact, offset by complementary measures ⁽²⁾
Maintain attractiveness of CBD to commercial tenants	Yes, through delivery of: <ul style="list-style-type: none"> • Alternative commuting options • Attract private carpark supply • Other Council parking supply • Non-parking attractants to CBD 	 CBD attractiveness driven by wide range of factors – carpark overall impact manageable
Contribute to mode shift and modern transport strategy	Yes, mode shift will be accelerated not delayed by Carpark removal	 No negative impact, potential positive contribution

Note 1: These constraints are summarised as implications arising from the original perceived TCC policy objectives, and the table explores whether, if the carpark is abandoned, they can be managed by other means

Note 2: Complementary measures include but are not limited to the Graduated Management Approach proposed by MRCagney – see backup slide

M.R.CAGNEY 'GRADUATED MANAGEMENT APPROACH' IS AN ALTERNATIVE PROCESS FOR MANAGING DEMAND/SUPPLY

Graduated management approach and supply decision making

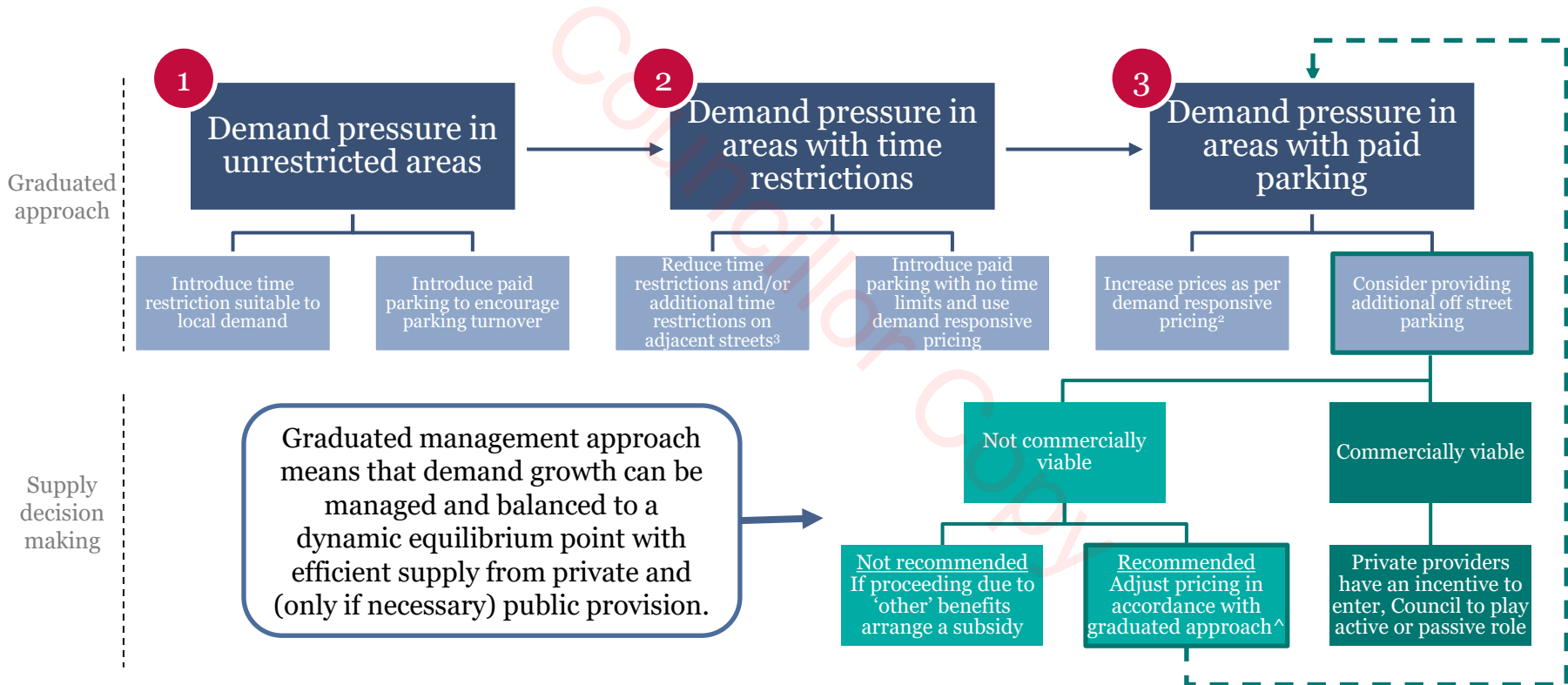

Source: MRCagney Technical Notes, Parking management approaches (Auckland, Wellington, Christchurch)

Notes: ¹ Not intended as a comprehensive summary of MRCagney recommendations. Similar approaches or proposals (excluding 'supply decision making') currently in progress in Auckland, Wellington, and Christchurch. Graduated management approaches and flexible pricing ensures optimal prices and encourage parking turnover while avoid overpricing at time of insufficient demand.

MCDA CONSIDERS FINANCIAL AND OTHER FACTORS TOGETHER; DEMOLISH OPTION STILL PREFERRED

Themes	Criteria	Weight	Complete (HG)	Demolish	Demo, rebuild	Complete partial	Complete full, raise prices
Financial and economic Weight: 60%	Net Present Value	50%	-4	2	-6	-6	0
	Affordability	25%	-4	2	-6	-2	-4
	Risk of cost overrun	25%	-6	1	-1	-5	-6
Benefits Weight: 20%	Mode shift encouraged	30%	-6	2	-6	-4	2
	Releases land for other use ¹	15%	2	-2	2	0	3
	Attracts commercial tenants to CBD ¹	30%	3	-2	3	2	1
Reputation Weight: 20%	Attracts retail customers ¹	25%	2	-2	2	1	3
	Council shows leadership	60%	-4	0	-2	-2	0
	Instils confidence in central Government	40%	-2	-4	-6	-4	0
	Total		-3.2	0.6	-3.4	-3.4	-1.0
	Rank		3	1	5	4	2

Note 1: Internalises management of constraints from slide 20. See sensitivity analysis in backup slide.

Note 2: Weights have been estimated using interviews with TCC staff, PAB members and SHS team development

DEMOLITION OPTION IS ALSO MOST RESILIENT TO CHANGING THEME WEIGHTS IN SENSITIVITY TESTS

Alternative theme weights

		Alternative weights			
Theme	Default weight	W1	W2	W3	W4
Financial	60%	50%	40%	50%	33%
Benefits	25%	25%	30%	50%	33%
Reputation	15%	25%	30%	0%	34%

Option rankings under alternative weights

MCA Scores	Default	W1	W2	W3	W4	Variance			
Complete (HG)	-3.21	-3.08	-2.79	-2.30	-2.60	0.90	3		
Demolish	0.01	-0.23	-0.42	-0.03	-0.55	0.56	5		
Demo, rebuild	-3.42	-3.30	-3.01	-2.43	-2.82	0.99	2		
Complete partial	-3.36	-3.16	-2.85	-2.55	-2.63	0.81	4		
Complete full, raise prices	-1.58	-1.23	-0.77	-0.70	-0.47	1.11	1		
								Low variance = resilient to weightings	
								High variance = sensitive to weightings	
								high variance less likely to attract broad support.	
MCA Ranking	Default	W1	W2	W3	W4				
Complete (HG)	3	3	3	3	3				
Demolish	1	1	1	1	2				
Demo, rebuild	5	5	5	4	5				
Complete partial	4	4	4	5	4				
Complete full, raise prices	2	2	2	2	1				

AGENDA

Project background

Financial assessment

Wider assessment

Recommendation and next steps

COUNCIL SHOULD ABANDON COMPLETION OPTIONS AND DECIDE WHAT TO DO WITH THE SITE

Demolish option performed best based on analysis of available evidence

Recommendation is to abandon Completion options and plan to Demolish

Having abandoned Completion, a range of forward options are possible

Communications should make clear the financial benefits of Demolition option

SUMMARY: “DEMOLISH” OPTION PERFORMED BEST BASED ON ANALYSIS OF AVAILABLE EVIDENCE

Lowest net cost

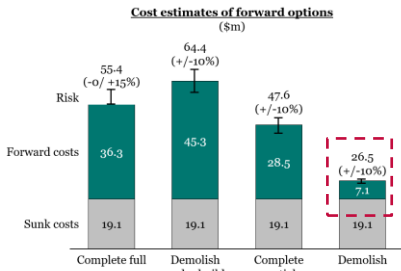

Highest NPV

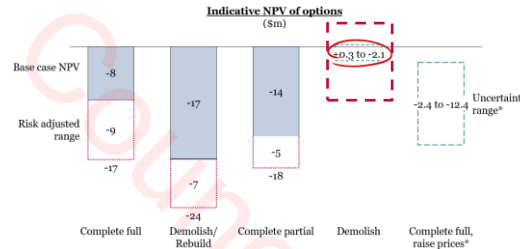

RWDA preference

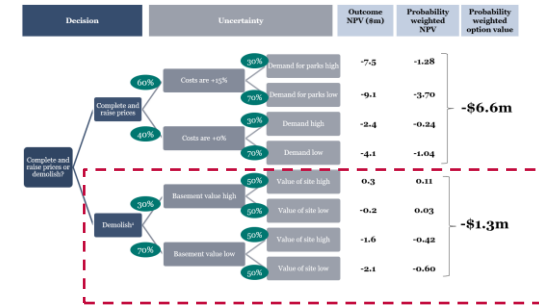

Uncertain demand

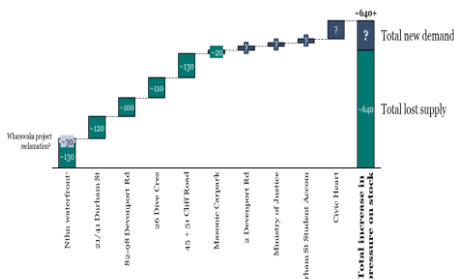

Viable alternatives

Perceived constraint ₍₁₎	Can it be navigated?	Impact of 'Demolish' option
Maintain sufficient CBD parking supply to meet demand	Yes, through optimised pricing, regulation or new (private) supply provision, and reforecast demand	Partial impact, offset by complementary measures ₍₂₎
Maintain attractiveness of CBD to commercial tenants	Yes, through delivery of: • Alternative commuting options • Attract private carpark supply • Other Council parking supply • Non-parking attractants to CBD	CBD attractiveness driven by wide range of factors – carpark overall impact manageable
Contribute to mode shift and modern transport strategy	Yes, mode shift will be accelerated not delayed by Carpark removal	No negative impact, potential positive contribution

MCDA confirmed

Themes	Criteria	Weight	Complete (HG)	Demolish	Demo, rel. still	Complete partial	Complete full, raise prices
Financial and economic	Net Present Value	50%	-4	2	-6	-6	0
	Affordability	25%	-4	2	-6	-2	-4
	Risk of cost overrun	25%	-6	1	-1	-5	-6
Benefits	Mode shift encouraged	30%	-6	2	-6	-4	2
	Releases land for other use ³	15%	2	-2	2	0	3
	Attracts commercial tenants to CBD	30%	3	-2	3	2	1
Reputation	Attracts retail customers ¹	25%	2	-2	2	1	3
	Council shows leadership	60%	-4	0	-2	-2	0
	Instils confidence in central Government	40%	-2	0	-6	-4	0
Total			-3.2	0.6	-3.4	-3.4	-1.0
Rank			3	1	5	4	2



Outcome: “Demolish” option is preferred based on evidence available

RECOMMENDATION IS TO ABANDON 'COMPLETION' OPTIONS AND PLAN TO DEMOLISH

'Demolition' has least cost, best NPV, even after risk assessment and constraint evaluation

- Even with most favourable risk, occupancy and pricing assumptions

Abandoning completion is the best way to minimise losses and additional overrun risk

- Probability-weighted decision analysis supports this conclusion

Parking consequences of abandoning Completion are uncertain and manageable by other means if necessary

Multi-criteria decision analysis (MCDA) ranks the demolition option as most favourable taking full range of factors into account

Having discontinued Completion, a range of future scenarios are possible

- Low holding cost infers positive option value to pause before Demolition

HAVING ABANDONED COMPLETION, A RANGE OF FORWARD OPTIONS ARE POSSIBLE

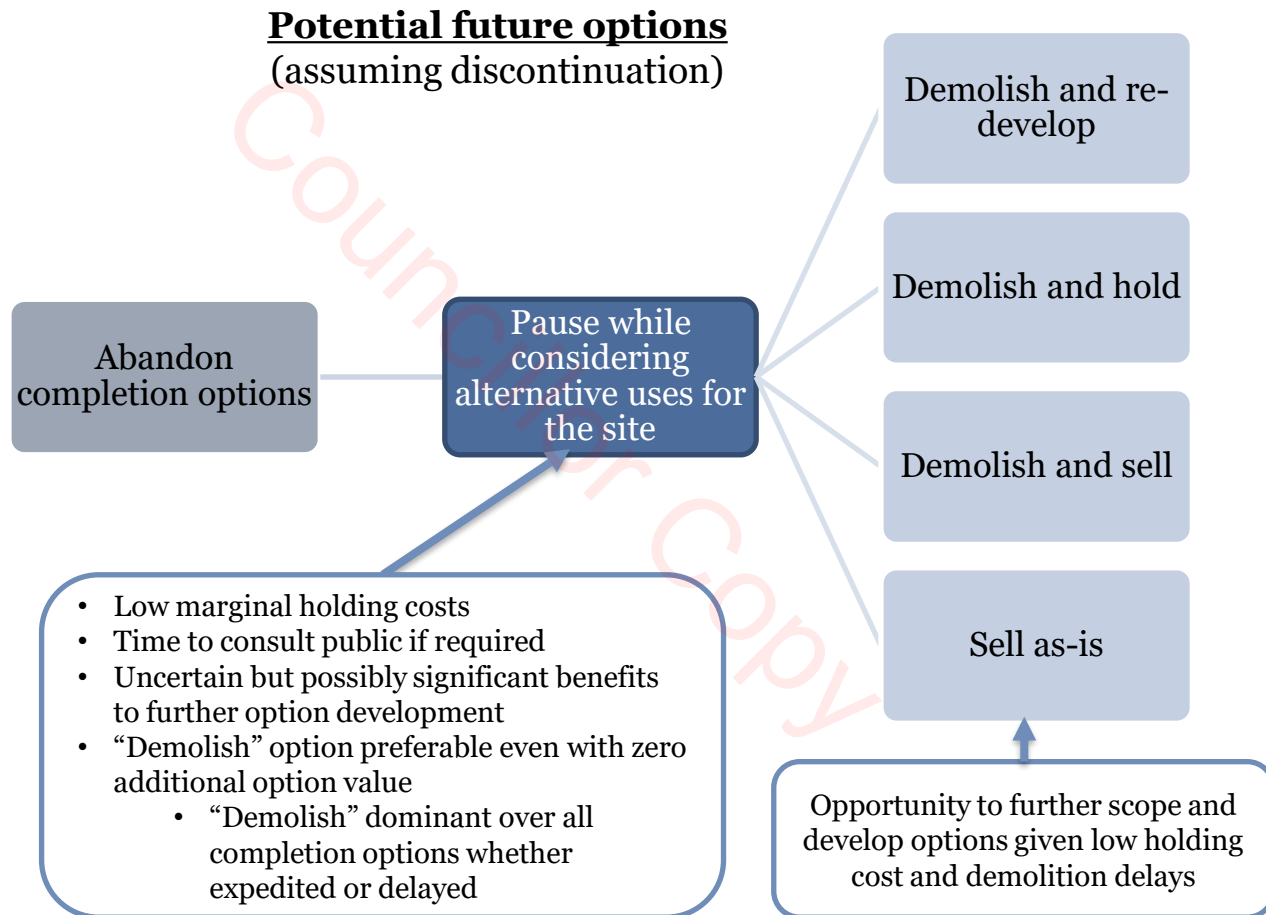

COMMUNICATIONS SHOULD BE PROACTIVE, VALUE-BASED AND CAREFULLY ALIGNED

Council communications team may wish to consider communicating that:

- Independent advice was taken on engineering, financial and management issues surrounding the project
- Completion costs were high and escalating, with ongoing costs
- Analysis showed losses to ratepayers would be far worse if Completion were pursued
- Demolition is clearly preferable even after risks and sensitivities were assessed
- Council has range of options to monitor and manage uncertain future parking demand

Advice should consider proactive communication and stakeholder management

- Once all relevant decisions confirmed
- [REDACTED]
- With clear, agreed and consistent key messages for all Council members, officers and supporters

Aurecon New Zealand Limited
Level 4, 139 Carlton Gore Road
Newmarket Auckland 1023
PO Box 9762
Newmarket Auckland 1149
New Zealand

T +64 9 520 6019
F +64 9 524 7815
E auckland@aurecongroup.com
W aurecongroup.com



2020-06-23

Tauranga City Council
C/- Malcolm Sabourin
TSA
Level 2, 88 Broadway,
Newmarket
Auckland 1023

Email: Malcolm.Sabourin@tsamgt.com

Dear Sir

Harington Street Transport Hub (HSTH) – Peer Review Report

Aurecon were engaged by Tauranga City Council (TCC) in 2019 to provide structural engineering design review services in respect of the structural remedial works to the TCC Harington Street Transport Hub building.

Design concerns regarding the HSTH building had been raised in an earlier high-level review by others of the building during construction. Subsequently construction of the building was put on hold whilst these concerns were addressed and the design of required remedial works undertaken by the structural designer Harrison Grierson (HG), supported by Compusoft Engineering Limited (CEL).

Aurecon's role was to:

- Provide initial input into the framing of solutions and ensuring all issues were identified.
- Provide a peer review of the remedial design to confirm compliance of the remedial works design with the Building Code and provision of a design review producer statement PS2 to assist in securing Building Consent for the works.

The following outlines the issues that needed to be addressed and the progress achieved at the time the project was halted by TCC in May 2020.

1 Building Structural System.

The primary structure of the building comprises the following:

- All floors are constructed from 160 mm thick slabs poured onto Traydec 80/1.2 mm thick sheet sheeting supported on structural steel beans and columns. The deck is affixed to the supporting beams with steel studs. Between grids C & F the floors are not level but form the ramp providing access to the parking levels as well as parking along their slope.
- Lateral loads arising from both wind and seismic effects were to be resisted by braced steel frames down to ground floor, with the perimeter basement walls stabilising the building over the 2 basement levels. The frames on grids 1 & 7 were founded atop the basement walls and those on grids C & F extended to the lower basement raft.
- The main structural steel framing members were to be painted on completion for both durability and fire rating.
- To moderate the seismic actions that could arise in the event of the ULS design event the forces in the diagonals of the bracing systems were to be limited using INERD pins. As there is no NZ

standard to provide a means of compliance for these devices the design was to be considered as an alternative design.

An earlier high-level qualitative assessment of the design by others had noted that the presence of the continuous ramp had not been adequately considered in the original design and the revised design should allow for seismic separation in one of the ramps at each level. A number of other concerns were identified including the capacity of the foundations, load transfer from collectors into the braced frames, transfer of floor diaphragm loads and diaphragm capacities, precast stair supports and car park barrier designs.

2 Remediation Approach and Issues

2.1 Foundations

One of the issues identified by the initial reviewers was that the relative thin basement slab, acting as a one-way raft spanning between transverse foundation beams located on column grids, did not comply with the concrete standard NZ3101 with regard to its shear capacity. With the shear demand in the slab over areas of each span between the transverse foundation beams exceeding 50% of the concrete shear capacity of the slab, some form of shear reinforcement such as links were required to comply with NZS3101. This was overlooked in the original design.

Consequently, a second overlay slab was designed by HG, appropriately reinforced to disperse the full loading demands from the columns into the underlaying ground. Any contribution from the existing slab was disregarded. Use was made of the existing transverse foundation beams, with the overlay slab dowel anchored to the beams.

2.2 Superstructure

Seismic separation of the ramp at each level was introduced, through formation of a seismic joint across the northern ramp. This has the consequence of enhancing the demands on the braced frames.

2.2.1 Lateral Load Analysis

- Since the design was required to be documented as an alternative design in terms of the Building Code and a base requirement that as many of the existing INERD pines were to be retained the decision was taken by the designers to use nonlinear time history analyses to determine the response of the structure.
- At an early stage consideration was given to adding extra braces atop the basement walls on grids A & H and on grids 3 & 5 which founded on the tops of the walls on grids A & H and the basement slab at grids B & G.
- The addition of these additional braces on grids A & H was abandoned as the connection of the diagonals aligned to the major axis of the columns rather than the minor axis introduced other complications. Those on grids 3 & 5 were abandoned as it was considered inappropriate to have one column of the braced frame founded on a vertically stiff wall and the other on the basement slab.

2.2.2 Loadings

- It was agreed the SDL allowance could be reduced to 0.25 kPa from a 1kPa allowance in the original design.

- The site had been identified by the geotechnical engineers as having an underlying soil class of type D.
- In order to provide ground motion records to simulate the response of the structure a set of seven records were amplitude scaled as required by NZS1170.5. This standard only requires the use of three records, the worst response is considered to define the required action. The NZSSE Base Isolation Guidelines and ACSE 7-16 consider the use of the average of at least seven records to be more appropriate.
- The average so determined was then scaled by a factor that is related to the deviation of the individual values from the average.

2.2.3 Modelling of the INERD Pins

The key consideration of for the seismic simulations was the load v deformation characteristics (backbone curve) of the pin element of the connection between the brace and the column. Papers published by a consortium of European Universities formed the basis for the evaluation of the performance of the INERD pin connection. The key aspects of these connections are:

- The dimensions of the actual INERD pin which can be either circular or rectangular. For the HSTH they are all rectangular.
- The clear distance between the inner plates and outer plates. The inner plates engage the pins and are connected to the end of the actual brace. The outer plates engage the pins and connect them to the outside of the column flanges.
- The actual equations that define backbone curve are presented in the research papers. When verifying the determination of these curve some basic issues were identified.
 - The load capacity of the pins when displaced to the limit of their usable deformation limit was being underestimated.
 - The design documentation did not adjust the connection in those storeys where the column size reduced. This had the effect that the connection to the column at the underside of the floor above was both stiffer and stronger than that at the floor level. ETABS models had to be amended to take cognisance of this, in some instances this required modification of the connection geometry.
 - Alterations had been proposed by the contractor to the as built locations of the column splices. While these had been accepted for construction this information was not depicted on the drawings on which the structural model was based.

2.2.4 Materials

The Nonlinear time history simulation of the effects of seismic action is based on the assessment of the probable properties of the materials. This includes the actual yield strength and the ultimate tensile strength for the deflection-controlled elements which for the HSTH are the INERD pins. Hence INERD pins are required to be able to sustain significant plastic strains.

While the steel plates had mill certificates for some the mechanical properties, there were no documented values for the Z value of the plate material. This is an important parameter that determines the suitability of the plate for welding such that the attached plate/sections at right angles to the plate.

It may be that the existing plate used in these details has the required Z value, but Aurecon considered it important that this be verified as the design requires that these plates do not delaminate when subject to through thickness strains.

2.2.5 Connections

The consented structural drawings for the connections were presented as a set of two-dimensional details. This did not correctly consider all the forces required to be transferred at a junction.

While all connections are important three are more difficult than the others.

- The connections of the base plated to the braced frames on grids 1 & 7 to the top of the walls are particularly challenging. The connection of these braced frames to the underlying wall can have tensions and shears across the interface and at the same time allow the column to rotate freely on this surface to be consistent with the analysis. It is not possible to replicate the weld pattern on both the upper and lower surfaces of the base plate and this was proving difficult for HG to resolve.
- The connection of the INERD pin plates to the columns, beams aligned to the braces and the beams normal to the braces all intersect at this location. The following aspects appear to have been overlooked in the original design and were required to be addressed.
 - The outer plates of the INERD pin connections when the brace is in compression are required to restrain the pin node in the out of plane direction in addition resisting bending induced by the pins and transferring the axial force into the column flanges. This in turn creates additional actions in the bolts connecting these plates to the flanges as well as the flange plates themselves.
 - The beams aligned with the braces and acting as collector elements to the brace bays are offset in plan from the outer column flanges, resulting in the lateral load applied through the web of the columns which could readily distort. A more robust connection of these beams to the outer plates to the columns of the braced bays is required.
 - The beams that frame into the columns normal to the bracing frames need to connect onto the outer plates of the INERD pin connections via a cleat plate welded to the outer plates. These beams carry gravity loads and at some locations axial loads associated with the diaphragm actions. The influence of these actions needs to be considered in determination of the bolts connecting the outer plates to the column flanges.
- The column splices where the overall column dimensions change at the splice. These had been derived considering the plates and bolts required where there was no such dimension change. Since the sections do not match an end plate was welded to the column and packers, welds and bolts used to connect across the interface. Aurecon believe there are deficiencies in this process and that further consideration was required.

2.2.6 Diaphragm Analysis

The analysis of the actions to be resisted by the diaphragms has been problematic for many structures and is complicated for the HSTH by the presence of the ramps.

There is no formal standard covering the determination of diaphragm actions. Most recent NZ designs and evaluations have used a pESA approach. This was derived primarily for reinforced concrete frames design using equivalent static process or response spectrum process to determine demand imposed on the structure.

Both above design processes result in a structural configuration in which the deformation-controlled elements, INERD pins for the HSTH, are always the same strength as or stronger than those in the storey above.

Given the desire to limit the number of INERD pins to be changed this does not occur in this structure and combined with the complication arising from the ramps no sensible approach was identified for the analysis of the diaphragms using the PESA methodology.

Analyses had been commenced incorporating a grillage model of the diaphragms as would be utilised in the pESA methodology within the main nonlinear time history analysis process.

2.2.7 Other Items

The discussion above relates to the issues that were dominating the redesign process. The following still required resolution but were not considered be as problematic as those above.

- The accommodation of inter-storey displacements so to not impose loads on the stairs and cladding system.
- Resolving a possible weakness of the precast stairs at the junction of the flight and its uppermost landing at each level.

3 Remediation Design & Peer Review Progress

At the time that TCC decided to abandon the completion of the HSTH, the following had been achieved in respect to the remediation design being undertaken by HG and Aurecon's peer review of such;

- Foundations -New foundation overlay slab design completed and documented, peer review completed/closed out, PS2 issued, dated 23 April 2020.
- Carpark barriers to building perimeter – design/documentation completed by HG, peer review completed/closed out.
- INERD Braces – INERD pin principles confirmed by HG/CEL and accepted by Aurecon. Final pin arrangements and modifications requirements to pin connection plates subject to floor diaphragms being capable of being strengthened to transfer loads between braces and columns.
 - Outer plates to INERD pin connections to columns under review by HG.
 - Overall lateral stability of braces under review by HG.
 - Restraint to maintain inner plates at centre of INERD pins still to be addressed by HG.
- Collectors to braced bays- revised connection details of collector beams to braced bay columns still to be provided by HG.
- Grids 1 & 7 Braced Bay Column Connections to basement walls – amended detailing in progress by HG.
- Basement Walls – confirmation of basement wall capacities to resist Grid 1 & 7 brace loads in progress by HG.
- Grid C&F Braced Frame Column Bases – connection between column and base plates to be reviewed by HG.
- Column Strengthening – scope of column strengthening identified, detailing of the plate strengthening substantially completed by HG.
- Column Splices – amended splices to columns to be finalised by HG.
- Structural Steel Z values – testing of existing steel plate sections for Z Values still to be completed.
- Floor Diaphragms – modelling and derivation of diaphragm demands in progress, diaphragm strengthening designs to be finalised by HG
- Precast Stairs – revised lateral restraint and interstorey sliding provisions in progress by HG, resolution of channel support arrangement at sliding end to be finalised, strengthening of junction of stair flight and uppermost landing to be finalised by HG.

- Accommodation of interstorey drift by cladding system, notable along length of ramps, to be resolved by HG.
- Additional columns at ramp separation – web crushing/ buckling through floor beams to be reviewed by HG.
- Adequacy of roof bracing – still to be reviewed by HG.

The above should not necessarily be considered a full and complete list of all the issues that need to be addressed regarding remedial works required to satisfy Building Code requirements in respect to the design of the building.

We have, for example, not looked at any remedial actions required to ensure the ongoing durability of the structure as part of our review.

We trust the above provides you with the necessary advice on the progress achieved in respect to the remedial design. Please feel free to contact the undersigned should you have any queries.

Yours faithfully

A handwritten signature in blue ink, appearing to read "Craig Stevenson".

Craig Stevenson
Technical Director – Built Environment